

THIS DRAWING IS THE PROPERTY OF ADDA CORPORATION AND SHOULD NOT BE DISCLOSED TO ANY THIRD PARTY WITHOUT WRITTEN CONSENT

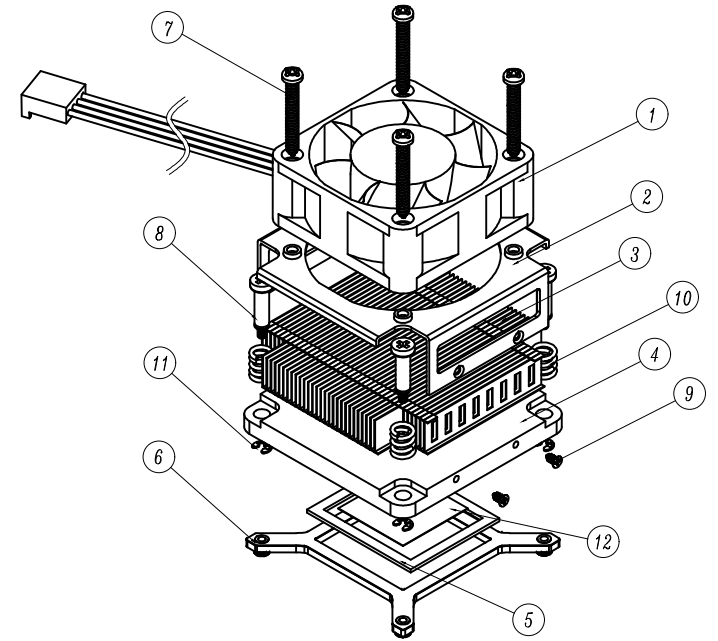
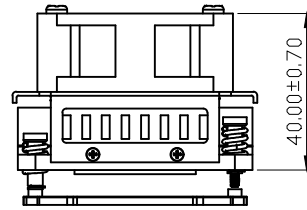
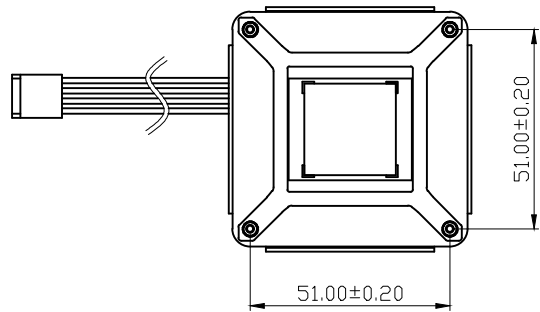
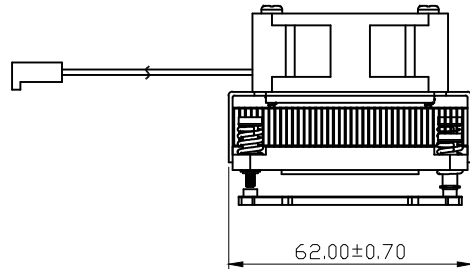
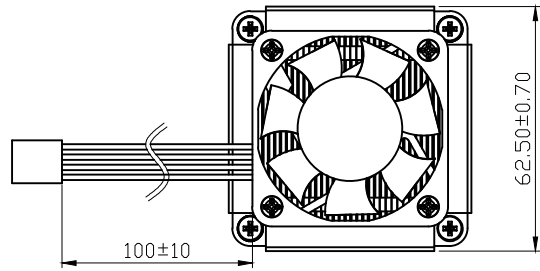

NOTE:
 1.VISUAL QUALITY IN ACCORDANCE WITH ADDA CORPORATION SPECIFICATION
 2.MUST BE ROHS COMPLIANT
 3.TOLERANCE:

UNLESS OTHERWISE SPECIFIED

DIMENSION	TOLERANCE		
	REFINED	MIDDLE	ROUGH
< 5mm	±0.06	±0.12	±0.2
5mm~60mm	±0.15	±0.2	±0.3
60mm~200mm	±0.25	±0.35	±0.7
> 200mm	±0.5	±1.0	±2.0
USED			✓

(TAIPEI THERMAL DEPT.)

12	1	PAD	PCS-TC-11
11	4	E-CLIP	SK7
10	4	SPRING	SWC
9	4	COVER SCREW	STEEL
8	4	SCREW	SEA-1018
7	4	FAN SCREW	SEA-1018
6	1	BACK PLATE + TAPE	SPCC + G9000
5	1	SPONGE	ML-32
4	1	CU BASE	CU 1100
3	1	AL FIN	AL 1100
2	1	COVER	AL 5052
1	1	FAN	AD5012UB-C7B(NSH10)
Item	Q'ty	Description	Material

Model No.	CLO0016	PART No.	9WCL00016X0A0001
DESCRIPTION	ASSEMBLY		
MATERIAL	SEE CHART	屬性：無鉛	
FINISH	N/A		
SCALE	QTY/SET	UNLESS OTHERWISE SPECIFIED, THE FOLLOWING APPLIES: GENERAL WALL THICKNESS= MM; DRAFTS= DEG. TOLERANCE LINEAR MM; ANGULAR: DEG. IMPORTANT; DO NOT SCALE DRAWING, ASK IN CASE OF QUERY	
1:1 mm	1		
PROJECTION			
DWN.BY	Cash	CHKD BY	APPD BY
		ADD A CORPORATION	
		禁止使用有害環境物質 符合 SONY SS-00259 技術標準要求	

REVISIONS

FAN SPEC(In Module)

Rated Current	0.3 Amp +10%
Rated Voltage	12 V
Rated Speed	8000 rpm ±10%

SPECIFICATION FOR APPROVAL

TO : _____

REF. No. _____

APPROVED DATE 	CHECKED DATE  	PREPARED DATE 
--	---	--

MODEL No. AD5012UB-C7B P.S. (NS)

DESCRIPTION: DC FAN (RoHS) REV. A

ID No. _____

THIS OFFER IS MADE ACCORDING TO YOUR CURRENT INQUIRY.
UNLESS OTHERWISE REVISED, THIS SPECIFICATION WILL BE FINAL FOR
ALL FUTURE PRODUCTION OF ORDERS FROM YOUR RESPECTED COMPANY

KINDLY STUDY IN DETAILS AND RETURN TO US THE DUPLICATE DULY
SIGNED AS YOUR CONFIRMATION OF SAME.



ADDA CORPORATION

BRUSHLESS AXIAL COOLING FANS

Customer	:		Ref: (RoHS)
Adda Model No	:	AD5012UB-C7B	P.S: (NS)
Samples attached	:	Piece(s),	
Safety Approval	:	CE	CE:EN 61000-6-1:2007 EN 61000-6-3:2007

Specifications

ITEM	SPECIFICATION / CONDITION			
DIMENSIONS	:	50x50x20	mm	
BEARING TYPE	:	BALL		
RATED VOLTAGE	:	12.0	VDC	
OPERATING VOLTAGE RANGE	:	10.8	VDC - 13.2	VDC
START - UP DUTY	:	9.0	VDC	, NOMINAL (Duty cycle 100%)
REAL CURRENT	:	0.18	Amp	
REAL POWER	:	2.16	Watt	
RATED CURRENT	:	0.30	Amp	+ 10 %MAX
RATED POWER	:	3.60	Watt	
RATED SPEED	:	PWM	Duty 100%	12v 6000 RPM ± 10 %
	:	PWM	Duty 0%	0 RPM
(IN FREE AIR AT RATED VOLTAGE)				
AIR FLOW	:	20.000	CFM	(min.: 18.000 CFM)
AIR FLOW	:	0.566	CMM	(min.: 0.509 CMM)
(IN FREE AIR AT RATED VOLTAGE)				
STATIC AIR PRESSURE	:	0.210	Inch H ₂ O	(min.: 0.170 Inch H ₂ O)
STATIC AIR PRESSURE	:	5.334	mm H ₂ O	(min.: 4.320 mm H ₂ O)
(IN FREE AIR AT RATED VOLTAGE)				
NOISE LEVEL	:	38.4	dB (A)	(max.: 42.4 dB(A))
MOTOR PROTECTION	:	BY	IC	
POLARITY PROTECTION	:	YES		
CONNECTION LEAD TYPE	:	WIRE, AWG#	26	
LIFE EXPECTANCY	:	70000	Hours at	40 / 65% RH
NET WEIGHT	:	32	Gram.	
PACKING	:	416	pcs.	Per Export Carton.

* If no PWM signal is present (no connection to the PWM drive signal) then the fan should run at maximum RPM.

* The fan must start spinning with a 35% duty cycle or less.

Unless otherwise stated, the relative humidity is 65%, and the temperature is 25 for the standard testing.

Should you have any doubt, please refer to the environmental conditions specified in the acknowledgement document.



SPECIFICATION

1.0 SCOPE

- 1.1 If the information or other related document is inconsistent with this acknowledgement document, please refer to the acknowledge document.
- 1.2 This documentation defines the mechanical & electrical characteristics of DC brushless fans.
- 1.3 The specification of this product is described in details in the acknowledgement document. No guarantee is given to our product under the use of over specifications.
- 1.4 For any change or amendment to the specifications, such change will be noticed in writing beforehand.
- 1.5 If the product is used on the MIS system, please specify the specification in the purchase order.

2.0 MATERIAL

- 2.1 Frame : UL94V-0 Glass Filled polyester (P.B.T)
- 2.2 Fan Blade : UL94V-0 Glass Filled polyester (P.B.T)

- 2.3 Bearing Sys. : () Sleeve, oil impregnated.
(V) Two Ball Bearing
() One Ball one Sleeve
() Hypro Bearing
() FDB Bearing
- 2.4 RoHS : (V) YES
HF : () YES

3.0 DIMENSIONS & CONSTRUCTION

All dimensions, Direction of rotation and air flow were specified as per drawing attached.

4.0 CHARACTERISTICS & DEFINITION

- 4.1 All rated characteristics were specified as per data sheet enclosed.
- 4.2 Rated Current : Rated Current shall be measured after 3 minutes of continuous rotation at rated voltage.
- 4.3 Rated Speed : Rated Speed shall be measured after 3 minutes of continuous rotation at rated voltage.
- 4.4 Start Voltage : The voltage which is able to start the fan to operate by suddenly switching 'ON'.
- 4.5 Input Power : Input Power shall be measured after 3 minutes of continuous rotation at rated voltage.
- 4.6 Locked Rotor Current : Locked current shall be measured within one minute of rotor locked, after 3 minutes of continuous rotation at rated voltage in clean air.
- 4.7 Air Flow & Static Pressure : The air flow data and static pressures should be determined in accordance with AMCA-210 standard or DIN24163 specification in a doublechamber testing with intake – side measurement.
- 4.8 Noise Level : The measurement of noise level is carried out with reference to CNS8753 in an anechoic chamber with the microphone positioned 1 meter from the air intake. Testing fan shall be hung in clean air.

NOISE LEVEL MEASUREMENT

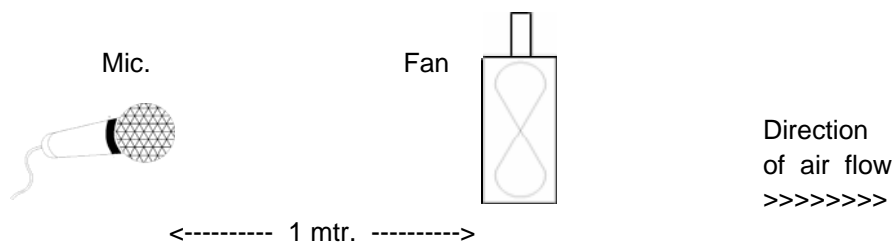

SPECIFICATION

5.0 MECHANICAL INSPECTION

5.1 Rotation Direction

Counterclockwise when look into impeller side.

5.2 Protection

All fans have integrated protection against locked rotor condition so that there will be no damage to winding or any electronic component.

Restarting is automatic as soon as any constraint to rotation has been released.

As fan placed at dead angle position, and the switch was changed from off to on. Restarting was automatic normal as soon as and proved that this fan is good fan.

5.3 Locked Rotor Protection

No damage shall be found after 72 hours continuously at condition of rotation locked.

Restarting is automatic as soon as constraint to running has been released.

5.4 Avoid the damage, check the correct voltage and proper polarity before connecting with power.

5.5 Free Drop Shock

In minimum package condition, the fan should withstand drops on any three faces from a height of 30cm onto a wood board of 10mm thick.

5.6 Please do not stick a grease and/or an oil to the fan housing or blade which may have a harmful influence by a chemical reaction at high humidity.

5.7 If the fan is reinstalled, please pay special attention to the noise due to the vibration (or resonance).

5.8 During the testing of the fan, please make sure the finger guard is used for safety.

6.0 ELECTRICAL INSPECTION

6.1 Insulation Resistance

Not less than 10M ohm between housing and positive end of lead wire (red) at 500V DC.

6.2 Dielectric Strength

No damage should be found at 500 VAC for 60 seconds, measured with 1mA trip current between housing and positive end of lead wire.

6.3 Life Expectancy

The continuous duty life at given temperature after which, 90% of testing units shall still be running.

6.4 While the fan is running, do not intentionally lock the fan for a long time since the overheating of the motor produced by the long-time locking will damage the fan.

7.0 ENVIRONMENTAL

7.1 Improper use such as disassembling the fan, being covered with dust, or dipping the fan in water that results in defects is not covered in the warranty. Do not use the fan in the environment with corrosive air or liquid.

7.2 Operating Temperature / Humidity

-10 to +70 at humidity 65%+/-20% RH.

7.3 Storage Temperature

All function shall be normal after 500 hours storage at -40 to +70 with a 24 hour recovery period at room temperature.

7.4 Humidity

After 96 hours, 95% RH, 40+/-2 per MIL-STD-202F, method 103B humidity test, the measured data on insulation resistance and dielectric strength shall meet the specification.

7.5 Do not place or store the fan in the environment with high/low temperature/humidity. Do not store the fan for over 6 months; even if the fan is stored in room temperature for over 6 months, the fan may have the electric current leakage.



SPECIFICATION

8.0 REMARKS

- 8.1 Material and construction are subject to change without advance notice. The changes should be within specification.
- 8.2 All fans shall meet the quality inspection under sampling plan MIL-STD-105E as follow:

Critical	0.25%
Major	1.00%
Minor	2.50%

9.0 OUTLINE STYLING & DIMENSIONS

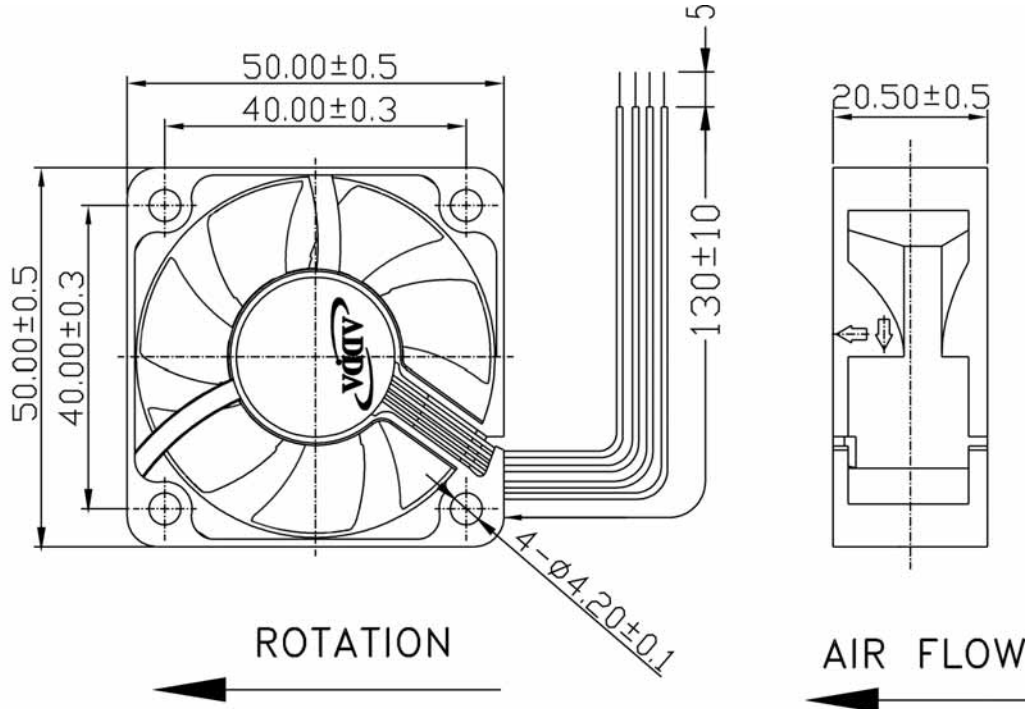

LEAD WIRES : UL 1061, AWG26, L = 130 +/- 10 mm
 Red = positive ; Black = negative.
 White = FG ; Blue = PWM

10.0 Notes:

- 10.1 Please do not touch and push Fan Blade with fingers or others, fan blade and ball bearings may be damaged and it causes noise defect.
- 10.2 Do not carry the fan by its lead wires.
- 10.3 If the fan does not have the polarity protection function, the connection of the colored wires should be red + red, and black + black, or else the fan will be damaged in no time.
- 10.4 For the models without reverse connection of polarity protection, please do not connect the lead wire in reverse
- 10.5 Please don't install this fan in series with 2x voltage inputs. For example, if a single fan rated at 12V, then don't install two of them in series with 24V input.
- 10.6. Every specific fan is designed for its certain application (project). Therefore, if you want to use this fan in other application (project), please inform ADDA first so that we can confirm whether there is any issue which might be incurred from the reason of this different application (project) or not.





PROVISION OF DIGITAL PWM SPEED CONTROL & LOCKED SIGNAL(F.G)

- OUTPUT OF LOCKED SIGNAL -----OPEN COLLECTOR TYPE

(External signal function design is decided by customer)

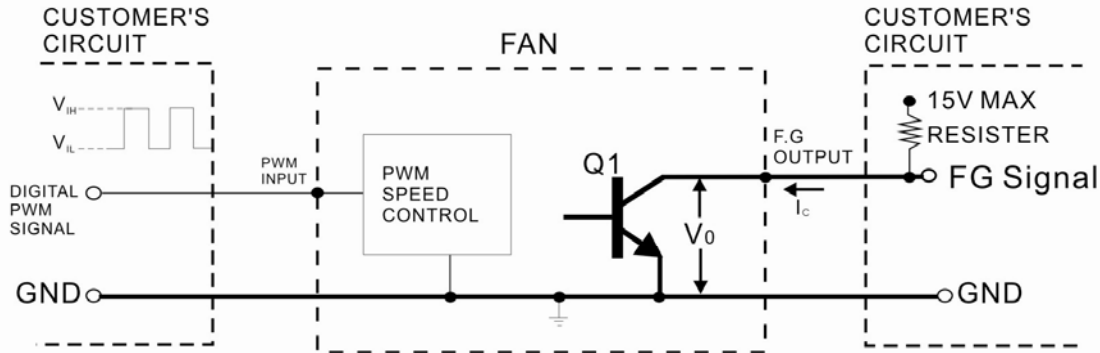

*TRANSISTOR Q1 AT "ON" POSITION

COLLECTOR CURRENT----- $I_c = 10\text{mA MAX}$

SATURATION VOLTAGE----- $V_{OL} = 1\text{ V MAX}$

*TRANSISTOR Q1 AT "OFF" POSITION

RELEASE VOLTAGE----- $V_{OH} = 15\text{ V MAX}$

*DIGITAL PWM SPEED CONTROL POSITION

PWM INPUT VOLTAGE HIGH----- $V_{IH} = 5.5\text{ V MAX}$

PWM INPUT VOLTAGE LOW----- $V_{IL} = 0.5\text{ V MAX}$

*PWM INPUT FREQUENCY----- $FPWM: 18\text{KHZ} \sim 30\text{KHZ}$

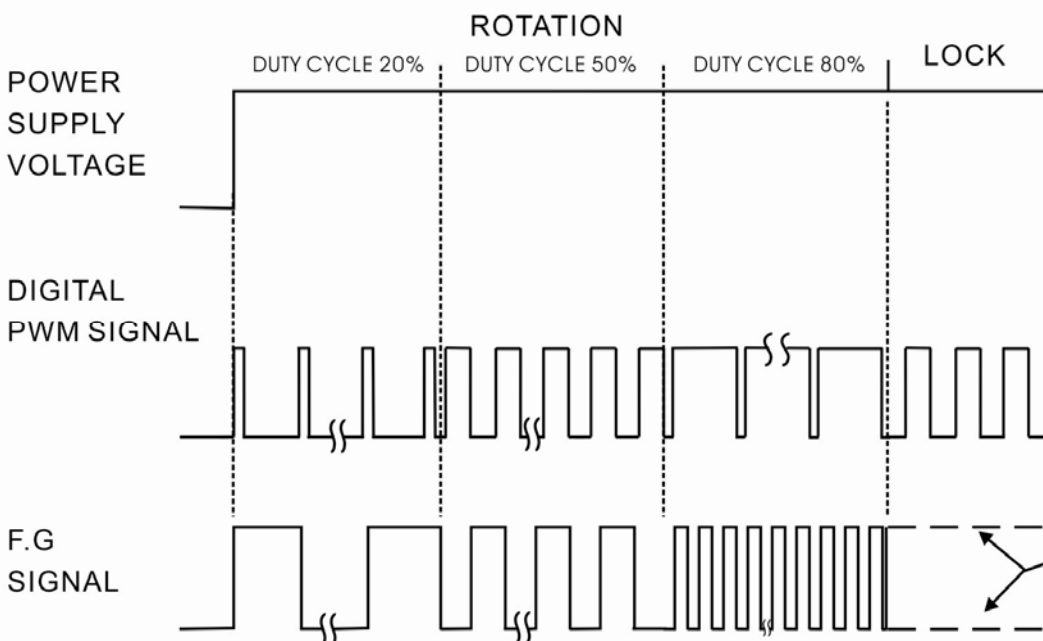



Adda Fan Performance Test Report

Static Pressure
mmH₂O inH₂O

Fan Model : AD5012UB-C7B(NS)

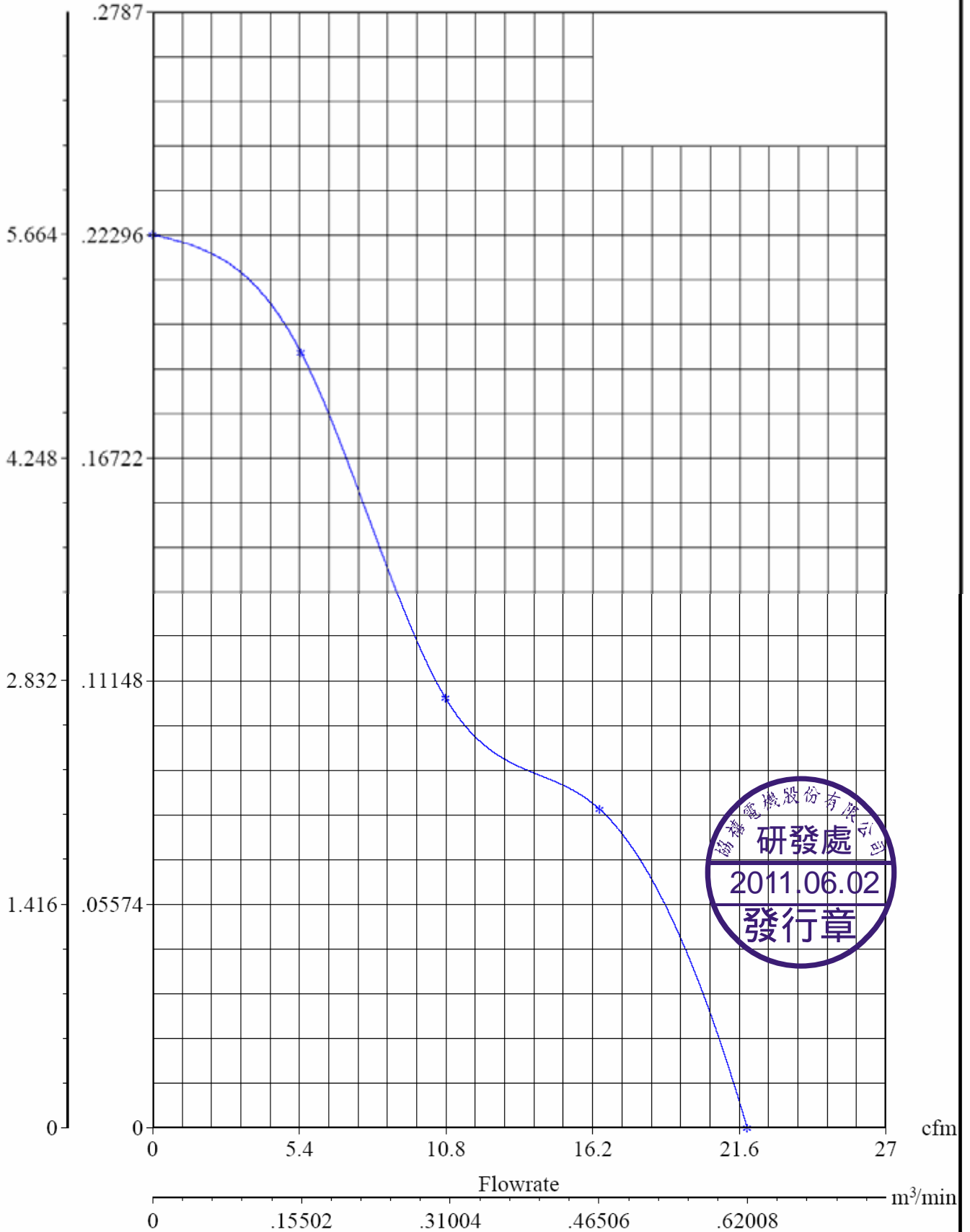

Approver :

Examiner :

Tester :