

» VX3327 «



3U VPX GPGPU Board

- » ATI Radeon™ E6760 Silicon
- » Modular design: MXM 3.0 mezzanine
- » Leading Edge Parallel Processing GPGPU
- » Air-cooled and Rugged Conduction-cooled Versions

The VX3327 offers leading edge parallel computing capabilities provided by the latest graphics processing units (GPUs) from AMD Radeon™. With the embedded AMD Radeon 6760 GPU, the VX3327 boasts 480 cores at 600 MHz and 1 GB GDDR5 for up to 576 GFlops single-precision floating-point performance.

The VX3327 is focused toward high-performance embedded computing applications such as radar, signals intelligence, and electronic warfare.

With the support of common open programming standards such as OpenCL 1.1 and DirectCompute 11, which is part of Microsoft's DirectX 11, OEMs benefit from highly efficient re-use and improved investment security for their valuable source code targeting GPGPUs in a heterogeneous system architecture.

The VX3327 is available in an air-cooled (0°C to +55°C) one inch (5 HP) version and conduction-cooled (-40°C to +85°C) 0.8 inch (4 HP) version.

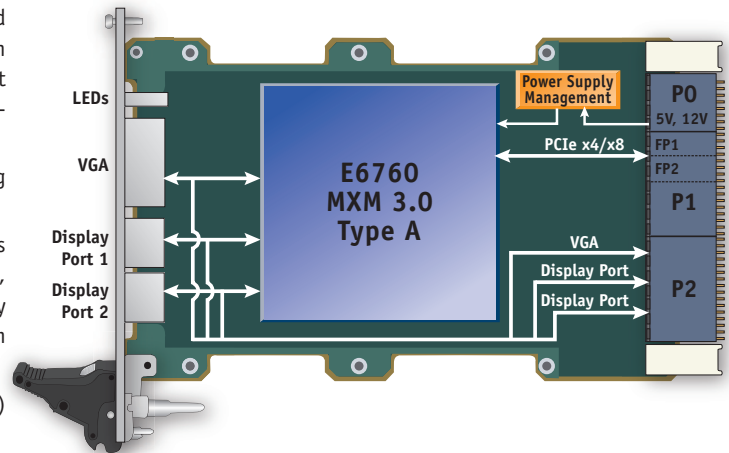

Technical Information

GPGPU	480 cores at 600 MHz, up to 576 GFlops (single precision floating point)
Display outputs	One VGA port and 2 DisplayPorts, up to 30 bits per pixel, VGA: triple 10 bits DAC, up to 400 MHz pixel rate Display Ports: x4 lanes, 5.4, 2.7- or 1.62 GHz link-data rate per lane » Up to 2560 × 1600 @ 60 Hz, 24 bpp with 2.7 GHz link » Up to 2560 × 2048 @ 60 Hz, 30 bpp with 5.4 GHz link
Host Interface	PCI-Express® Base Specification Revision 2.1, gen2 speed, x1, x2, x4 and x8
GPU Technology	40 nm GPU running at 600 MHz, Tj max 105 °C, On die temperature sensor, +/- 3°C
Memory	1 GB GDDR5, 128 bits, 800 MHz
Software	Linux and Windows operating systems, support for OpenGL 4.1, support for OpenCL™ 1.1.
Form Factor	MXM Version 3.0, Type A mounted on a 3U VPX carrier card (onboard PCIe retimer enhances signal integrity)

Environmental Specifications

	SA - Standard Commercial	RC - Rugged Conduction-Cooled
Conformal Coating	Optional	Standard
Airflow	1.5 m/s	N.A.
Temperature	VITA 47-Class AC1	VITA 47-Class CC4 (GPGPU usage), CC3 (3D graphics usage)
Cooling Method	Convection	Conduction
Operating / Storage	0°C to +55°C / -45°C to +85°C	-40°C to +85°C / -45°C to +100°C
Vibration Sine (Operating)	2g / 20-500 Hz, acceleration / frequency range	5g / 20-2,000 Hz, acceleration / frequency range
Random	VITA 47-Class V1	VITA 47-Class V3
Shock (Operating)	20g / 11 ms, peak accel. / duration half sine	40g / 20 ms, peak accel. / duration half sine
Altitude (Operating)	-1,640 to 60,000 ft	-1,640 to 60,000 ft
Relative Humidity	90% non-condensing (95% if coated version)	95% non-condensing

Ordering Information

Article	Part No.	Description
VX3327	VX3327-SA-01000	Air-cooled GPU E6760 board, 1" slot pitch, front graphics connectors
VX3327	VX3327-RC-0S100	Conduction-cooled GPU E6760 board, 0.8" slot pitch, no front connector

CORPORATE OFFICES

Europe, Middle East & Africa

Oskar-von-Miller-Str. 1
85386 Eching / Munich
Germany

Tel.: +49 8165 77 777
Fax: +49 8165 77 219
info@kontron.com

North America

14118 Stowe Drive
Poway, CA 92064-7147
USA

Tel.: +1 888 294 4558
Fax: +1 858 677 0898
info@us.kontron.com

Asia Pacific

17 Building, Block #1, ABP.
188 Southern West 4th Ring Road
Beijing 100070, P.R.China

Tel.: +86 10 63751188
Fax: +86 10 83682438
info@kontron.cn