

# » User Guide «

## **CP6003-RA/RC**

**Rugged 6U CompactPCI Processor Board based on  
the 2<sup>nd</sup> Generation Intel® Core™ i7 Processor with  
the Intel® QM67 Express Chipset**

Doc. ID: 1046-3890, Rev. 1.0  
December 16, 2011



## Revision History

Publication Title:		CP6003-RA/RC: Rugged 6U CompactPCI Processor Board based on the 2 <sup>nd</sup> Generation Intel® Core™ i7 Processor with the Intel® QM67 Express Chipset	
Doc. ID:		1046-3890	
Rev.	Brief Description of Changes		Date of Issue
1.0	Initial issue		16-Dec-2011

## Imprint

Kontron Modular Computers GmbH may be contacted via the following:

### MAILING ADDRESS

Kontron Modular Computers GmbH  
 Sudetenstraße 7  
 D - 87600 Kaufbeuren Germany

### TELEPHONE AND E-MAIL

+49 (0) 800-SALESKONTRON  
 sales@kontron.com

For further information about other Kontron products, please visit our Internet website: [www.kontron.com](http://www.kontron.com).

## Disclaimer

Copyright © 2011 Kontron AG. All rights reserved. All data is for information purposes only and not guaranteed for legal purposes. Information has been carefully checked and is believed to be accurate; however, no responsibility is assumed for inaccuracies. Kontron and the Kontron logo and all other trademarks or registered trademarks are the property of their respective owners and are recognized. Specifications are subject to change without notice.



## Table of Contents

<i>Revision History</i> .....	<i>ii</i>
<i>Imprint</i> .....	<i>ii</i>
<i>Disclaimer</i> .....	<i>ii</i>
<i>Table of Contents</i> .....	<i>iii</i>
<i>List of Tables</i> .....	<i>ix</i>
<i>List of Figures</i> .....	<i>xiii</i>
<i>Proprietary Note</i> .....	<i>xv</i>
<i>Trademarks</i> .....	<i>xv</i>
<i>Environmental Protection Statement</i> .....	<i>xv</i>
<i>Explanation of Symbols</i> .....	<i>xvi</i>
<i>For Your Safety</i> .....	<i>xvii</i>
<i>High Voltage Safety Instructions</i> .....	<i>xvii</i>
<i>Special Handling and Unpacking Instructions</i> .....	<i>xvii</i>
<i>General Instructions on Usage</i> .....	<i>xviii</i>
<i>Two Year Warranty</i> .....	<i>xix</i>
<b>1. Introduction</b> .....	<b>1 - 3</b>
1.1 <i>Board Overview</i> .....	1 - 3
1.2 <i>CP6003-RA Board-Specific Information</i> .....	1 - 4
1.3 <i>CP6003-RC Board-Specific Information</i> .....	1 - 5
1.4 <i>System Expansion Capabilities</i> .....	1 - 6
1.4.1 <i>PMC/XMC Module (CP6003-RA)</i> .....	1 - 6
1.4.2 <i>Conductive-Cooled PMC/XMC Module (CP6003-RC)</i> .....	1 - 6
1.4.3 <i>SATA Flash Module</i> .....	1 - 6
1.4.4 <i>Rear I/O Module</i> .....	1 - 6
1.5 <i>Version Comparison</i> .....	1 - 6
1.6 <i>Board Diagrams</i> .....	1 - 7
1.6.1 <i>Functional Block Diagram</i> .....	1 - 7
1.6.2 <i>Front Panel</i> .....	1 - 8
1.6.3 <i>Board Layout</i> .....	1 - 9
1.7 <i>Technical Specification</i> .....	1 - 13
1.8 <i>Standards</i> .....	1 - 20
1.9 <i>Related Publications</i> .....	1 - 22



<b>2. Functional Description .....</b>	<b>2 - 3</b>
2.1 Processor .....	2 - 3
2.2 Memory .....	2 - 4
2.3 Intel® QM67 Express Chipset .....	2 - 4
2.4 Timer .....	2 - 5
2.5 Watchdog Timer .....	2 - 5
2.6 Battery .....	2 - 5
2.7 Reset .....	2 - 5
2.8 Flash Memory .....	2 - 6
2.8.1 SPI Boot Flash for uEFI BIOS .....	2 - 6
2.8.2 Serial ATA Flash Module (Optional) .....	2 - 6
2.9 Trusted Platform Module 1.2 (On Request) .....	2 - 6
2.10 Board Interfaces .....	2 - 7
2.10.1 Onboard and Front Panel LEDs .....	2 - 7
2.10.1.1 IPMI LEDs and Hot Swap LED .....	2 - 7
2.10.1.2 Watchdog LED and Temperature Status LED .....	2 - 8
2.10.1.3 Debug LEDs .....	2 - 9
2.10.2 DIP Switches SW1, SW2 and SW3 (CP6003-RA) .....	2 - 11
2.10.3 Configuration Resistors (CP6003-RC) .....	2 - 11
2.10.4 USB Interfaces .....	2 - 12
2.10.4.1 USB Connectors J6 and J7 .....	2 - 12
2.10.5 Integrated Graphics Controller .....	2 - 12
2.10.5.1 Graphics Memory Usage .....	2 - 13
2.10.5.2 DisplayPort Interface (CP6003-RA) .....	2 - 13
2.10.6 COM Ports .....	2 - 14
2.10.7 Gigabit Ethernet .....	2 - 15
2.10.8 Serial ATA Interface .....	2 - 16
2.10.9 GPI and GPO Signals .....	2 - 16
2.10.10 PMC Interface .....	2 - 17
2.10.10.1 PMC Connectors J15, J16, J17 and J18 Pinout .....	2 - 19
2.10.11 XMC Interface .....	2 - 21
2.10.12 Debug Interface .....	2 - 22
2.10.13 CompactPCI Interface .....	2 - 22
2.10.13.1 Board Functionality when Installed in System Slot .....	2 - 22



2.10.13.2	<i>Board Functionality when Installed in Peripheral Slot</i>	2 - 23
2.10.13.3	<i>Packet Switching Backplane (PICMG 2.16)</i>	2 - 23
2.10.13.4	<i>Hot Swap Support</i>	2 - 23
2.10.13.5	<i>Power Ramping</i>	2 - 23
2.10.13.6	<i>Precharge</i>	2 - 23
2.10.13.7	<i>Handle Switch (CP6003-RA)</i>	2 - 23
2.10.13.8	<i>ENUM# Interrupt</i>	2 - 23
2.10.13.9	<i>Hot Swap LED (CP6003-RA)</i>	2 - 23
2.10.14	<i>CompactPCI Bus Connector</i>	2 - 24
2.10.14.1	<i>CompactPCI Connector Keying</i>	2 - 24
2.10.14.2	<i>CompactPCI Connectors J1 and J2 Pinout</i>	2 - 25
2.10.14.3	<i>CompactPCI Rear I/O Connectors J3-J5 and Pinout</i>	2 - 29
<b>3.</b>	<b><i>Installation</i></b>	<b>3 - 3</b>
3.1	<i>Safety Requirements</i>	3 - 3
3.2	<i>CP6003-RA Installation</i>	3 - 4
3.2.1	<i>CP6003-RA Initial Installation Procedures</i>	3 - 4
3.2.2	<i>Standard Removal Procedures</i>	3 - 5
3.2.3	<i>Hot Swap Procedures</i>	3 - 6
3.2.3.1	<i>System Master Hot Swap</i>	3 - 6
3.2.3.2	<i>Peripheral Hot Swap Procedure</i>	3 - 6
3.2.4	<i>Installation of CP6003-RA Peripheral Devices</i>	3 - 8
3.2.4.1	<i>USB Device Installation</i>	3 - 8
3.2.4.2	<i>SATA Flash Module Installation</i>	3 - 8
3.2.5	<i>PMC/XMC Module Installation</i>	3 - 9
3.2.5.1	<i>Rear I/O Device Installation</i>	3 - 9
3.2.6	<i>Battery Replacement</i>	3 - 9
3.3	<i>CP6003-RC Installation</i>	3 - 10
3.3.1	<i>Initial Installation Procedures</i>	3 - 10
3.3.2	<i>Standard Removal Procedures</i>	3 - 11
3.3.3	<i>Hot Swap Procedures</i>	3 - 12
3.3.3.1	<i>System Master Hot Swap</i>	3 - 12
3.3.3.2	<i>CP6003-RC Hot Swap Procedure</i>	3 - 12



- 3.3.4 Installation of CP6003-RC Peripheral Devices ..... 3 - 15
  - 3.3.4.1 USB Device Installation ..... 3 - 15
  - 3.3.4.2 Rear I/O Device Installation ..... 3 - 15
- 3.3.5 CCPMC/Conduction-Cooled XMC Module Installation ..... 3 - 16
- 3.4 Software Installation ..... 3 - 16

**4. Configuration ..... 4 - 3**

- 4.1 DIP Switches SW1, SW2 and SW3 Configuration (CP6003-RA) ..... 4 - 3
- 4.2 Configuration Resistors (CP6003-RC) ..... 4 - 5
- 4.3 Jumper Description ..... 4 - 6
  - 4.3.1 COMB Termination Jumper Settings ..... 4 - 6
- 4.4 I/O Address Map ..... 4 - 7
- 4.5 CP6003-RA/RC-Specific Registers ..... 4 - 8
  - 4.5.1 Status Register 0 (STAT0) ..... 4 - 8
  - 4.5.2 Status Register 1 (STAT1) ..... 4 - 9
  - 4.5.3 Control Register 0 (CTRL0) ..... 4 - 10
  - 4.5.4 Control Register 1 (CTRL1) ..... 4 - 11
  - 4.5.5 Device Protection Register (DPROT) ..... 4 - 12
  - 4.5.6 Reset Status Register (RSTAT) ..... 4 - 13
  - 4.5.7 Board Interrupt Configuration Register (BICFG) ..... 4 - 14
  - 4.5.8 Status Register 2 (STAT2) ..... 4 - 15
  - 4.5.9 Board ID High Byte Register (BIDH) ..... 4 - 15
  - 4.5.10 Board and PLD Revision Register (BREV) ..... 4 - 16
  - 4.5.11 Geographic Addressing Register (GEOAD) ..... 4 - 16
  - 4.5.12 Watchdog Timer Control Register (WTIM) ..... 4 - 17
  - 4.5.13 Board ID Low Byte Register (BIDL) ..... 4 - 19
  - 4.5.14 LED Configuration Register (LCFG) ..... 4 - 20
  - 4.5.15 LED Control Register (LCTRL) ..... 4 - 21
  - 4.5.16 General Purpose Output Register (GPOUT) ..... 4 - 22
  - 4.5.17 General Purpose Input Register (GPIN) ..... 4 - 22
  - 4.5.18 IPMI Keyboard Controller Style Interface ..... 4 - 22





<b>5. Power Considerations .....</b>	<b>5 - 3</b>
5.1 System Power .....	5 - 3
5.1.1 CP6003-RA/RC Baseboard .....	5 - 3
5.1.2 Backplane .....	5 - 3
5.1.3 Power Supply Units .....	5 - 4
5.1.3.1 Start-Up Requirement .....	5 - 4
5.1.3.2 Power-Up Sequence .....	5 - 4
5.1.3.3 Tolerance .....	5 - 4
5.1.3.4 Regulation .....	5 - 5
5.2 Power Consumption of CP6003-RA/RC .....	5 - 5
5.2.1 Power Consumption of the CP6003-RA/RC Accessories .....	5 - 8
5.2.2 Power Consumption per Gigabit Ethernet Port .....	5 - 8
5.3 Maximum Power Consumption of PMC Modules .....	5 - 8
5.4 Maximum Power Consumption of XMC Modules .....	5 - 9
<b>6. Thermal Considerations .....</b>	<b>6 - 3</b>
6.1 Board Internal Thermal Monitoring .....	6 - 3
6.2 Processor Thermal Monitoring .....	6 - 3
6.2.1 Digital Thermal Sensor (DTS) .....	6 - 3
6.2.2 Adaptive Thermal Monitor .....	6 - 4
6.2.2.1 Frequency/sVID Control .....	6 - 4
6.2.2.2 Clock Modulation .....	6 - 4
6.2.3 Catastrophic Cooling Failure Sensor .....	6 - 5
6.3 Chipset Thermal Monitor Feature .....	6 - 5
6.4 External Thermal Regulation for CP6003-RA .....	6 - 5
6.4.1 Operational Limits for the CP6003-RA .....	6 - 7
6.5 Thermal Characteristics for the CP6003-RC .....	6 - 8
6.6 Peripherals .....	6 - 10
<b>A. SATA Flash Module .....</b>	<b>A - 3</b>
A.1 Technical Specifications .....	A - 3
A.2 SATA Flash Module Layout .....	A - 4



This page has been intentionally left blank.







## List of Tables

1-1	<i>Version Comparison</i>	1 - 6
1-2	<i>CP6003-RA/RC Main Specifications</i>	1 - 13
1-3	<i>Standards for the CP6003-RA</i>	1 - 20
1-4	<i>Standards for the CP6003-RC</i>	1 - 21
1-5	<i>Related Publications</i>	1 - 22
2-1	<i>Features of the Processors Supported on the CP6003-RA/RC</i>	2 - 4
2-2	<i>IPMI LEDs and Hot Swap LED Function</i>	2 - 7
2-3	<i>Watchdog LED and Temperature Status LED Function</i>	2 - 8
2-4	<i>Debug LEDs Function</i>	2 - 9
2-5	<i>POST Code Sequence</i>	2 - 10
2-6	<i>POST Code Example</i>	2 - 10
2-7	<i>DIP Switch SW1 Function</i>	2 - 11
2-8	<i>DIP Switch SW2 Function</i>	2 - 11
2-9	<i>DIP Switch SW3 Function</i>	2 - 11
2-10	<i>Configuration Resistors</i>	2 - 11
2-11	<i>USB Connectors J6 and J7 Pinout</i>	2 - 12
2-12	<i>DisplayPort Connector J9 Pinout</i>	2 - 13
2-13	<i>Serial Connector J8 (COMA) Pinout</i>	2 - 14
2-14	<i>Gigabit Ethernet Port Mapping</i>	2 - 15
2-15	<i>Pinout of GbE Connector J10, J11 and J12</i>	2 - 16
2-16	<i>PMC PCI/PCI-X Configuration</i>	2 - 17
2-17	<i>PMC Connectors J16 and J18 Pinout</i>	2 - 19
2-18	<i>PMC Connectors J15 and J17 Pinout</i>	2 - 20
2-19	<i>XMC Connector J14 Pinout</i>	2 - 21
2-20	<i>CompactPCI PCI/PCI-X Configuration</i>	2 - 22
2-21	<i>CompactPCI Bus Connector J1 System Slot Pinout</i>	2 - 25
2-22	<i>CompactPCI Bus Connector J1 Peripheral Slot Pinout</i>	2 - 26
2-23	<i>64-bit CompactPCI Bus Connector J2 System Slot Pinout</i>	2 - 27
2-24	<i>64-bit CompactPCI Bus Connector J2 Peripheral Slot Pinout</i>	2 - 28
2-25	<i>CompactPCI Rear I/O Connector J3 Pinout</i>	2 - 29
2-26	<i>CompactPCI Rear I/O Connector J3 Signals</i>	2 - 30
2-27	<i>CompactPCI Rear I/O Connector J4 Pinout</i>	2 - 31



2-28	<i>CompactPCI Rear I/O Connector J5 Pinout</i>	2 - 32
2-29	<i>CompactPCI Rear I/O Connector J5 Signals</i>	2 - 33
4-1	<i>DIP Switch SW1 for CompactPCI Interface Configuration</i>	4 - 3
4-2	<i>DIP Switch SW2 for PMC Interface Configuration</i>	4 - 3
4-3	<i>DIP Switch SW3 for Boot Configuration</i>	4 - 4
4-4	<i>Configuration Resistors' Settings</i>	4 - 5
4-5	<i>JP2 Jumper Setting for RS-422 TXD Termination (COMB)</i>	4 - 6
4-6	<i>JP3 Jumper Setting for RS-422 RXD Termination (COMB)</i>	4 - 6
4-7	<i>I/O Address Map</i>	4 - 7
4-8	<i>Status Register 0 (STAT0)</i>	4 - 8
4-9	<i>Status Register 1 (STAT1)</i>	4 - 9
4-10	<i>Control Register 0 (CTRL0)</i>	4 - 10
4-11	<i>Control Register 1 (CTRL1)</i>	4 - 11
4-12	<i>Device Protection Register (DPROT)</i>	4 - 12
4-13	<i>Reset Status Register (RSTAT)</i>	4 - 13
4-14	<i>Board Interrupt Configuration Register (BICFG)</i>	4 - 14
4-15	<i>Status Register 2 (STAT2)</i>	4 - 15
4-16	<i>Board ID High Byte Register (BIDH)</i>	4 - 15
4-17	<i>Board and PLD Revision Register (BREV)</i>	4 - 16
4-18	<i>Geographic Addressing Register (GEOAD)</i>	4 - 16
4-19	<i>Watchdog Timer Control Register (WTIM)</i>	4 - 18
4-20	<i>Board ID Low Byte Register (BIDL)</i>	4 - 19
4-21	<i>LED Configuration Register (LCFG)</i>	4 - 20
4-22	<i>LED Control Register (LCTRL)</i>	4 - 21
4-23	<i>General Purpose Output Register (GPOUT)</i>	4 - 22
4-24	<i>General Purpose Input Register (GPIN)</i>	4 - 22
5-1	<i>Maximum Input Power Voltage Limits</i>	5 - 3
5-2	<i>DC Operational Input Voltage Ranges</i>	5 - 3
5-3	<i>Input Voltage Characteristics</i>	5 - 4
5-4	<i>uEFI Shell Mode</i>	5 - 7
5-5	<i>Win. XP with Processor and Graphics in Idle State</i>	5 - 7
5-6	<i>Win. XP with Red. Processor Frequency and Basic Graphics Operation</i>	5 - 7
5-7	<i>Win. XP with Max. Processor Workload and Basic Graphics Operation</i>	5 - 7
5-8	<i>Win. XP with Max. Processor and Graphics Workload</i>	5 - 7





---

5-9	<i>Power Consumption of CP6003-RA/RC Accessories</i>	5 - 8
5-10	<i>Power Consumption per Gigabit Ethernet Port</i>	5 - 8
5-11	<i>PMC/CCPMC Module Current</i>	5 - 8
5-12	<i>XMC/Conduction-Cooled XMC Module Current</i>	5 - 9
6-1	<i>Maximum Reference Point Temperature with Core™ i7-2715QE</i>	6 - 9
6-2	<i>Maximum Reference Point Temperature with Core™ i7-2655LE</i>	6 - 9
A-1	<i>SATA Flash Module Main Specifications</i>	A - 3





This page has been intentionally left blank.





## List of Figures

1-1	<i>CP6003-RA/RC Functional Block Diagram</i> .....	1 - 7
1-2	<i>CP6003-RA Front Panel</i> .....	1 - 8
1-3	<i>CP6003-RA Board Layout – Top View</i> .....	1 - 9
1-4	<i>CP6003-RC Board Layout – Top View</i> .....	1 - 10
1-5	<i>CP6003-RA Board Layout – Bottom View</i> .....	1 - 11
1-6	<i>CP6003-RC Board Layout – Bottom View</i> .....	1 - 12
2-1	<i>USB Connectors J6 and J7</i> .....	2 - 12
2-2	<i>DisplayPort Connector J9</i> .....	2 - 13
2-3	<i>Serial Connector J8 (COMA)</i> .....	2 - 14
2-4	<i>GbE Connectors J10, J11 and J12</i> .....	2 - 16
2-5	<i>PMC Connectors J15, J16, J17 and J18</i> .....	2 - 18
2-6	<i>XMC Connector J14</i> .....	2 - 21
2-7	<i>CompactPCI Connectors J1-J5</i> .....	2 - 24
3-1	<i>Connecting a Peripheral Device to the CP6003-RA</i> .....	3 - 8
3-2	<i>Connecting a Peripheral Device to the CP6003-RC</i> .....	3 - 15
4-1	<i>DIP Switches SW1, SW2 and SW3 (CP6003-RA)</i> .....	4 - 3
4-2	<i>Configuration Resistors (CP6003-RC)</i> .....	4 - 5
6-1	<i>CP6003-RA with Intel® Quad-Core i7-2715QE (SV), 2.1 GHz</i> .....	6 - 7
6-2	<i>CP6003-RA with Intel® Dual-Core i7-2655LE (LV), 2.2 GHz</i> .....	6 - 7
6-3	<i>Position of the Reference Point on the CP6003-RC</i> .....	6 - 8
A-1	<i>SATA Flash Module Layout (Bottom View)</i> .....	A - 4



This page has been intentionally left blank.





## Proprietary Note

This document contains information proprietary to Kontron. It may not be copied or transmitted by any means, disclosed to others, or stored in any retrieval system or media without the prior written consent of Kontron or one of its authorized agents.

The information contained in this document is, to the best of our knowledge, entirely correct. However, Kontron cannot accept liability for any inaccuracies or the consequences thereof, or for any liability arising from the use or application of any circuit, product, or example shown in this document.

Kontron reserves the right to change, modify, or improve this document or the product described herein, as seen fit by Kontron without further notice.

## Trademarks

Kontron, the *PEP* logo and, if occurring in this manual, “CXM” are trademarks owned by Kontron, Kaufbeuren (Germany). In addition, this document may include names, company logos and trademarks, which are registered trademarks and, therefore, proprietary to their respective owners.

## Environmental Protection Statement

This product has been manufactured to satisfy environmental protection requirements where possible. Many of the components used (structural parts, printed circuit boards, connectors, batteries, etc.) are capable of being recycled.

Final disposition of this product after its service life must be accomplished in accordance with applicable country, state, or local laws or regulations.



## Explanation of Symbols



### ***Caution, Electric Shock!***

This symbol and title warn of hazards due to electrical shocks (> 60V) when touching products or parts of them. Failure to observe the precautions indicated and/or prescribed by the law may endanger your life/health and/or result in damage to your material.

Please refer also to the section “High Voltage Safety Instructions” on the following page.



### ***Warning, ESD Sensitive Device!***

This symbol and title inform that electronic boards and their components are sensitive to static electricity. Therefore, care must be taken during all handling operations and inspections of this product, in order to ensure product integrity at all times.

Please read also the section “Special Handling and Unpacking Instructions” on the following page.



### ***Warning!***

This symbol and title emphasize points which, if not fully understood and taken into consideration by the reader, may endanger your health and/or result in damage to your material.



### ***Note ...***

This symbol and title emphasize aspects the reader should read through carefully for his or her own advantage.





## For Your Safety

Your new Kontron product was developed and tested carefully to provide all features necessary to ensure its compliance with electrical safety requirements. It was also designed for a long fault-free life. However, the life expectancy of your product can be drastically reduced by improper treatment during unpacking and installation. Therefore, in the interest of your own safety and of the correct operation of your new Kontron product, you are requested to conform with the following guidelines.

### High Voltage Safety Instructions



#### **Warning!**

All operations on this device must be carried out by sufficiently skilled personnel only.



#### **Caution, Electric Shock!**

Before installing a not hot-swappable Kontron product into a system always ensure that your mains power is switched off. This applies also to the installation of piggybacks.

Serious electrical shock hazards can exist during all installation, repair and maintenance operations with this product. Therefore, always unplug the power cable and any other cables which provide external voltages before performing work.

### Special Handling and Unpacking Instructions



#### **ESD Sensitive Device!**

Electronic boards and their components are sensitive to static electricity. Therefore, care must be taken during all handling operations and inspections of this product, in order to ensure product integrity at all times.

Do not handle this product out of its protective enclosure while it is not used for operational purposes unless it is otherwise protected.

Whenever possible, unpack or pack this product only at EOS/ESD safe work stations. Where a safe work station is not guaranteed, it is important for the user to be electrically discharged before touching the product with his/her hands or tools. This is most easily done by touching a metal part of your system housing.

It is particularly important to observe standard anti-static precautions when changing piggybacks, ROM devices, jumper settings etc. If the product contains batteries for RTC or memory backup, ensure that the board is not placed on conductive surfaces, including anti-static plastics or sponges. They can cause short circuits and damage the batteries or conductive circuits on the board.



---

## General Instructions on Usage

In order to maintain Kontron's product warranty, this product must not be altered or modified in any way. Changes or modifications to the device, which are not explicitly approved by Kontron and described in this manual or received from Kontron's Technical Support as a special handling instruction, will void your warranty.

This device should only be installed in or connected to systems that fulfill all necessary technical and specific environmental requirements. This applies also to the operational temperature range of the specific board version, which must not be exceeded. If batteries are present, their temperature restrictions must be taken into account.

In performing all necessary installation and application operations, please follow only the instructions supplied by the present manual.

Keep all the original packaging material for future storage or warranty shipments. If it is necessary to store or ship the board, please re-pack it as nearly as possible in the manner in which it was delivered.

Special care is necessary when handling or unpacking the product. Please consult the special handling and unpacking instruction on the previous page of this manual.



## Two Year Warranty

Kontron grants the original purchaser of Kontron's products a ***TWO YEAR LIMITED HARDWARE WARRANTY*** as described in the following. However, no other warranties that may be granted or implied by anyone on behalf of Kontron are valid unless the consumer has the express written consent of Kontron.

Kontron warrants their own products, excluding software, to be free from manufacturing and material defects for a period of 24 consecutive months from the date of purchase. This warranty is not transferable nor extendible to cover any other users or long-term storage of the product. It does not cover products which have been modified, altered or repaired by any other party than Kontron or their authorized agents. Furthermore, any product which has been, or is suspected of being damaged as a result of negligence, improper use, incorrect handling, servicing or maintenance, or which has been damaged as a result of excessive current/voltage or temperature, or which has had its serial number(s), any other markings or parts thereof altered, defaced or removed will also be excluded from this warranty.

If the customer's eligibility for warranty has not been voided, in the event of any claim, he may return the product at the earliest possible convenience to the original place of purchase, together with a copy of the original document of purchase, a full description of the application the product is used on and a description of the defect. Pack the product in such a way as to ensure safe transportation (see our safety instructions).

Kontron provides for repair or replacement of any part, assembly or sub-assembly at their own discretion, or to refund the original cost of purchase, if appropriate. In the event of repair, refunding or replacement of any part, the ownership of the removed or replaced parts reverts to Kontron, and the remaining part of the original guarantee, or any new guarantee to cover the repaired or replaced items, will be transferred to cover the new or repaired items. Any extensions to the original guarantee are considered gestures of goodwill, and will be defined in the "Repair Report" issued by Kontron with the repaired or replaced item.

Kontron will not accept liability for any further claims resulting directly or indirectly from any warranty claim, other than the above specified repair, replacement or refunding. In particular, all claims for damage to any system or process in which the product was employed, or any loss incurred as a result of the product not functioning at any given time, are excluded. The extent of Kontron liability to the customer shall not exceed the original purchase price of the item for which the claim exists.

Kontron issues no warranty or representation, either explicit or implicit, with respect to its products' reliability, fitness, quality, marketability or ability to fulfil any particular application or purpose. As a result, the products are sold "as is," and the responsibility to ensure their suitability for any given task remains that of the purchaser. In no event will Kontron be liable for direct, indirect or consequential damages resulting from the use of our hardware or software products, or documentation, even if Kontron were advised of the possibility of such claims prior to the purchase of the product or during any period since the date of its purchase.

Please remember that no Kontron employee, dealer or agent is authorized to make any modification or addition to the above specified terms, either verbally or in any other form, written or electronically transmitted, without the company's consent.



This page has been intentionally left blank.





*Chapter*

**1**

---

# Introduction

---



This page has been intentionally left blank.





# 1. Introduction

## 1.1 Board Overview

The CP6003-RA (Rugged Air-Cooled) / CP6003-RC (Rugged Conductive-Cooled) is a highly integrated 6U CompactPCI system controller board based on the 2<sup>nd</sup> generation Intel® Core™ i7 processors combined with the mobile Intel® QM67 Express chipset.

The board supports the 2<sup>nd</sup> generation, quad-core Intel® Core™ i7-2715QE processor with 2.1 GHz and the 2<sup>nd</sup> generation, dual-core, low-voltage Intel® Core™ i7-2655LE processor with 2.2 GHz. All processors are built on 32-nm technology and provided in a BGA package. The CP6003-RA/RC includes up to 16 GB dual-channel DDR3 soldered memory with Error Checking and Correction (ECC) running at 1333 MHz. Furthermore, up to 32 GB NAND flash memory (SSD) via a SATA Flash module can be integrated into the CP6003-RA/RC.

The CP6003-RA has a front panel and comes with various interfaces such as up to five Gigabit Ethernet ports (three on front I/O and up to four on rear I/O in compliance with PICMG 2.16), four high-resolution graphics interfaces (DisplayPort, VGA, 2 x HDMI/DVI), two COM ports (RS-232 on front and rear I/O, RS-422/RS-232 on rear I/O), and five SATA interfaces with RAID 0/1/5/10 functionality, one for the SATA Flash module and four for rear I/O. In addition, six USB 2.0 ports, two on front I/O and four on rear I/O as well as four general purpose inputs (GPI) and four general purpose outputs (GPO) are available on the board. The CP6003-RA provides support for one standard PMC/XMC module either via one 64-bit/66 MHz PCI or 64-bit/133 MHz PCI-X PMC interface or via one XMC interface utilizing a x8 lane PCI Express 2.0 interconnection.

The CP6003-RC has no front panel and provides various interfaces such as four Gigabit Ethernet ports on rear I/O in compliance with PICMG 2.16, three high-resolution graphics interfaces (VGA, 2 x HDMI/DVI), two COM ports (RS-232 and RS-422/RS-232 on rear I/O), and five SATA interfaces with RAID 0/1/5/10 functionality, one for the SATA Flash module and four for rear I/O. In addition, four USB 2.0 ports on rear I/O as well as four general purpose inputs (GPI) and four general purpose outputs (GPO) are available on the board. The CP6003-RC provides support for one conduction-cooled PMC (CCPMC)/one conduction-cooled XMC either via one 64-bit/66 MHz PCI or 64-bit/133 MHz PCI-X PMC interface or via one XMC interface utilizing a x8 lane PCI Express 2.0 interconnection.

The CP6003-RA/RC supports a configurable 64-bit/66 MHz PCI or PCI-X hot swap CompactPCI interface. When installed in the system slot, the interface is enabled, and when installed in a peripheral slot, the CP6003-RA/RC is isolated from the CompactPCI bus. Safety and security features via a Trusted Platform Module (TPM) 1.2 are provided on request. Intelligent Platform Management Interface (IPMI) is supported as well.

The CP6003-RA/RC has an extended operating temperature range and is ruggedized for high shock and vibration environments. The CP6003-RA provides a heat sink optimized for air cooling. The CP6003-RC provides a heat spreader extending across the whole board to enable the heat to be conducted from the board to the chassis. On the CP6003-RC two wedge locks are available for mounting the board in the chassis.

Designed for stability, the board fits into applications situated in industrial environments, including I/O intensive applications where only one slot is available for the CPU, making it a perfect core technology for long-life applications. Components with high temperature tolerance have been selected from embedded technology programs, and therefore offer long-term availability. The board is offered with various Board Support Packages including Windows, VxWorks and Linux operating systems. For further information concerning the operating systems available for the CP6003-RA/RC, please contact Kontron.



## 1.2 CP6003-RA Board-Specific Information

The CP6003-RA is a rugged air-cooled CompactPCI single-board computer with front I/O. It is based on the 2<sup>nd</sup> generation Intel® Core™ i7 processor and specifically designed for use in highly integrated platforms with solid mechanical interfacing for a wide range of industrial environment applications.

Some of the CP6003-RA's outstanding features are:

- Support for the following 2<sup>nd</sup> generation processors:
  - Quad-core Intel® Core™ i7-2715QE (SV), 2.1 GHz, 6 MB L3 cache
  - Dual-core Intel® Core™ i7-2655LE (LV), 2.2 GHz, 4 MB L3 cache
- Intel® QM67 Express chipset
- Up to 16 GB, dual-channel, soldered DDR3 SDRAM memory with ECC running at 1333 MHz
- Integrated 3D high-performance graphics controller with up to four high-resolution graphics interfaces (VGA / DP / 2 x HDMI/DVI)
- 64-bit/66 MHz PCI or PCI-X CompactPCI interface (PICMG 2.0)
- One PMC slot with PCI functionality and rear I/O support; 64-bit/66 MHz PCI interface or 64-bit/133 MHz PCI-X interface
- One XMC slot utilizing a x8 lane PCI Express 2.0 interconnection
- Five Gigabit Ethernet interfaces:
  - Two Gigabit Ethernet interfaces switchable between front I/O and rear I/O
  - Two Gigabit Ethernet interfaces on rear I/O (PICMG 2.16)
  - One Gigabit Ethernet interface on front I/O
- Two Gigabit Ethernet (GbE) controllers:
  - One Intel® 82579LM Gigabit Ethernet controller connected to one GbE port on the front panel
  - One Intel® 82580EB Quad Gigabit Ethernet controller connected to two GbE ports on the front panel and two GbE ports on the rear I/O
- Five Serial ATA interfaces with SATA RAID 0/1/5/10 support:
  - One onboard SATA 6 Gb/s interface for the Serial ATA Flash module
  - Four SATA 3 Gb/s interfaces on the rear I/O
- Six USB ports:
  - Two USB 2.0 ports on the front panel
  - Four USB 2.0 ports on the rear I/O
- Two COM ports:
  - One RS-232 COM port either on the front panel or on the rear I/O (COMA)
  - One RS-422/RS-232 COM port on the rear I/O (COMB)
- TCG 1.2 compliant Trusted Platform Module (TPM), on request
- Two SPI boot flashes:
  - One standard SPI boot flash
  - One recovery SPI boot flash
- Four general purpose inputs (GPI) and four general purpose outputs (GPO) on rear I/O
- Watchdog timer
- Battery-backed real-time clock
- Three onboard DIP switches for board configuration
- Supports PICMG Packet Switching Backplane Specification 2.16
- IPMI support
- 4HP, 6U CompactPCI
- Passive heat sink solution for forced airflow cooling
- Rear I/O on J3, J4 and J5
- Hot swap capability: as system controller or as peripheral device
- AMI Aptio®, a uEFI-compliant platform firmware





### 1.3 CP6003-RC Board-Specific Information

The CP6003-RC is a rugged conductive-cooled CompactPCI single-board computer without front I/O. It is based on the 2<sup>nd</sup> generation Intel® Core™ i7 processor and specifically designed for use in highly integrated platforms with solid mechanical interfacing for a wide range of industrial environment applications.

Some of the CP6003-RC's outstanding features are:

- Support for the following 2<sup>nd</sup> generation processors:
  - Quad-core Intel® Core™ i7-2715QE (SV), 2.1 GHz, 6 MB L3 cache
  - Dual-core Intel® Core™ i7-2655LE (LV), 2.2 GHz, 4 MB L3 cache
- Intel® QM67 Express chipset
- Up to 16 GB, dual-channel, soldered DDR3 SDRAM memory with ECC running at 1333 MHz
- Integrated 3D high-performance graphics controller with up to three high-resolution graphics interfaces (VGA / 2 x HDMI/DVI)
- 64-bit/66 MHz PCI or PCI-X CompactPCI interface (PICMG 2.0)
- One conductive-cooled PMC slot with PCI functionality and rear I/O support; 64-bit/66 MHz PCI interface or 64-bit/133 MHz PCI-X interface
- One conductive-cooled XMC slot utilizing a x8 lane PCI Express 2.0 interconnection
- Four Gigabit Ethernet interfaces:
  - Two Gigabit Ethernet interfaces on rear I/O with disable option in uEFI BIOS
  - Two Gigabit Ethernet interfaces on rear I/O (PICMG 2.16)
- One Gigabit Ethernet controller:
  - One Intel® 82580EB Quad Gigabit Ethernet controller connected to the Gigabit Ethernet ports on the rear I/O
- Five Serial ATA interfaces with SATA RAID 0/1/5/10 support:
  - One onboard SATA 6 Gb/s interface for the Serial ATA Flash module
  - Four SATA 3 Gb/s interfaces on the rear I/O
- Four USB ports on the rear I/O
- Two COM ports:
  - One RS-232 COM port on the rear I/O (COMA)
  - One RS-422/RS-232 COM port on the rear I/O (COMB)
- TCG 1.2 compliant Trusted Platform Module (TPM), on request
- Two SPI boot flashes:
  - One standard SPI boot flash
  - One recovery SPI boot flash
- Four general purpose inputs (GPI) and four general purpose outputs (GPO) on rear I/O
- Watchdog timer
- Supports PICMG Packet Switching Backplane Specification 2.16
- IPMI support
- 4HP, 6U CompactPCI
- Passive heat sink solution for conductive-cooling
- Rear I/O on J3, J4 and J5
- AMI Aptio®, a uEFI-compliant platform firmware



## 1.4 System Expansion Capabilities

### 1.4.1 PMC/XMC Module (CP6003-RA)

The CP6003-RA has a 3.3V, rear I/O capable PMC mezzanine interface configurable for either 64-bit/66 MHz PCI or 64-bit/133 MHz PCI-X operation with support for PMC modules. For information on the PMC interface, refer to chapter 2.10.10, "PMC Interface".

The CP6003-RA has one XMC mezzanine interface for support of x1, x4 and x8 PCI Express 2.0 XMC modules. For information on the XMC interface, refer to chapter 2.10.11, "XMC Interface".

### 1.4.2 Conductive-Cooled PMC/XMC Module (CP6003-RC)

The CP6003-RC has a 3.3V, rear I/O capable PMC mezzanine interface configurable for either 64-bit/66 MHz PCI or 64-bit/133 MHz PCI-X operation with support for conductive-cooled PMC (CCPMC) modules. For information on the PMC interface, refer to chapter 2.10.10, "PMC Interface".

The CP6003-RC has one XMC mezzanine interface for support of x1, x4 and x8 PCI Express 2.0 conductive-cooled XMC modules. For information on the XMC interface, refer to chapter 2.10.11, "XMC Interface".

### 1.4.3 SATA Flash Module

The CP6003-RA/RC provides support for up to 32 GB NAND flash memory in combination with an optional SATA Flash module, which is connected to the CP6003-RA/RC via an onboard SATA extension connector. For further information concerning the SATA Flash module, please refer to Appendix A.

### 1.4.4 Rear I/O Module

The CP6003-RA/RC provides support for one rear I/O module via the CompactPCI rear I/O connectors. For further information about the compatibility of rear I/O modules with the CP6003-RA/RC, please refer to the CP6003-RA/RC datasheet.

## 1.5 Version Comparison

**Table 1-1: Version Comparison**

FEATURE	CP6003-RA	CP6003-RC
Heat sink	Air-cooled heat sink	Conductive-cooled heat sink
PMC/XMC	Standard PMC/XMC	Conductive-cooled PMC/XMC
Front Ethernet port	Up to 3 GbE ports	--
Rear Ethernet port	Up to four GbE ports	Up to four GbE ports
Front DisplayPort	1	--
Front COM port (RS-232)	1	--
Front LEDs	4	--
Cooling	Convection	Conduction

## 1.6 Board Diagrams

The following diagrams provide additional information concerning board functionality and component layout.

### 1.6.1 Functional Block Diagram

Figure 1-1: CP6003-RA/RC Functional Block Diagram

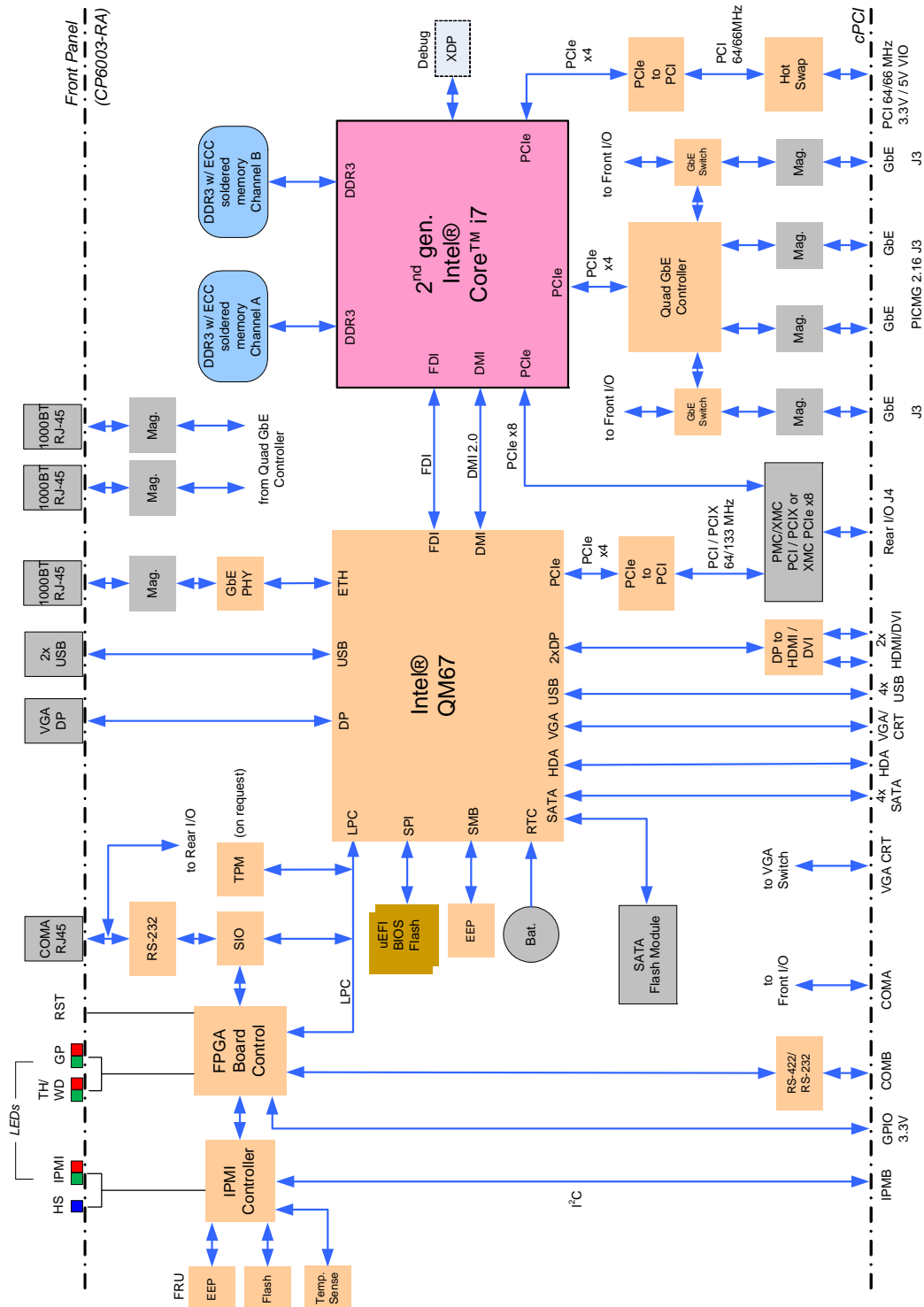



1.6.2 Front Panel

Figure 1-2: CP6003-RA Front Panel

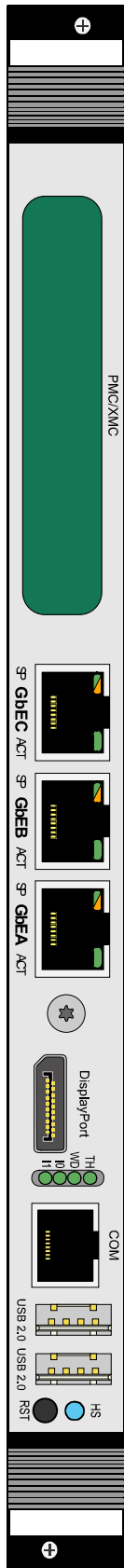

**Legend:**

**IPMI LEDs**

I0/I1 (red/green): Indicate the software status of the IPMI controller

**Status LEDs**

WD (green): Watchdog Status

TH (red/green): Temperature Status

HS (blue): Hot Swap Control

**Integral Ethernet LEDs**

ACT (green): Ethernet Link/Activity

SPEED (green/orange/off): Ethernet Speed

1.6.3 Board Layout

Figure 1-3: CP6003-RA Board Layout – Top View

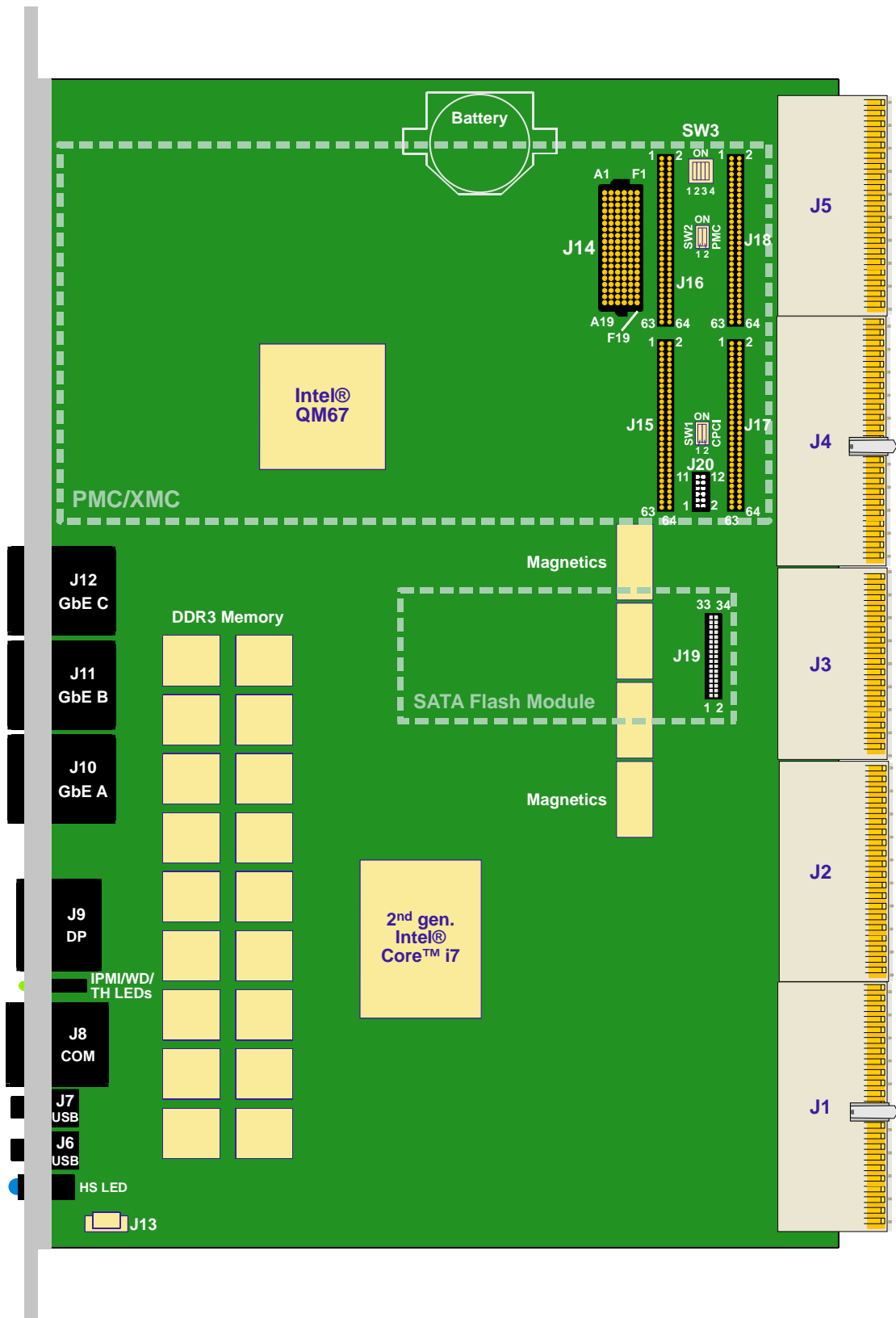



Figure 1-4: CP6003-RC Board Layout – Top View

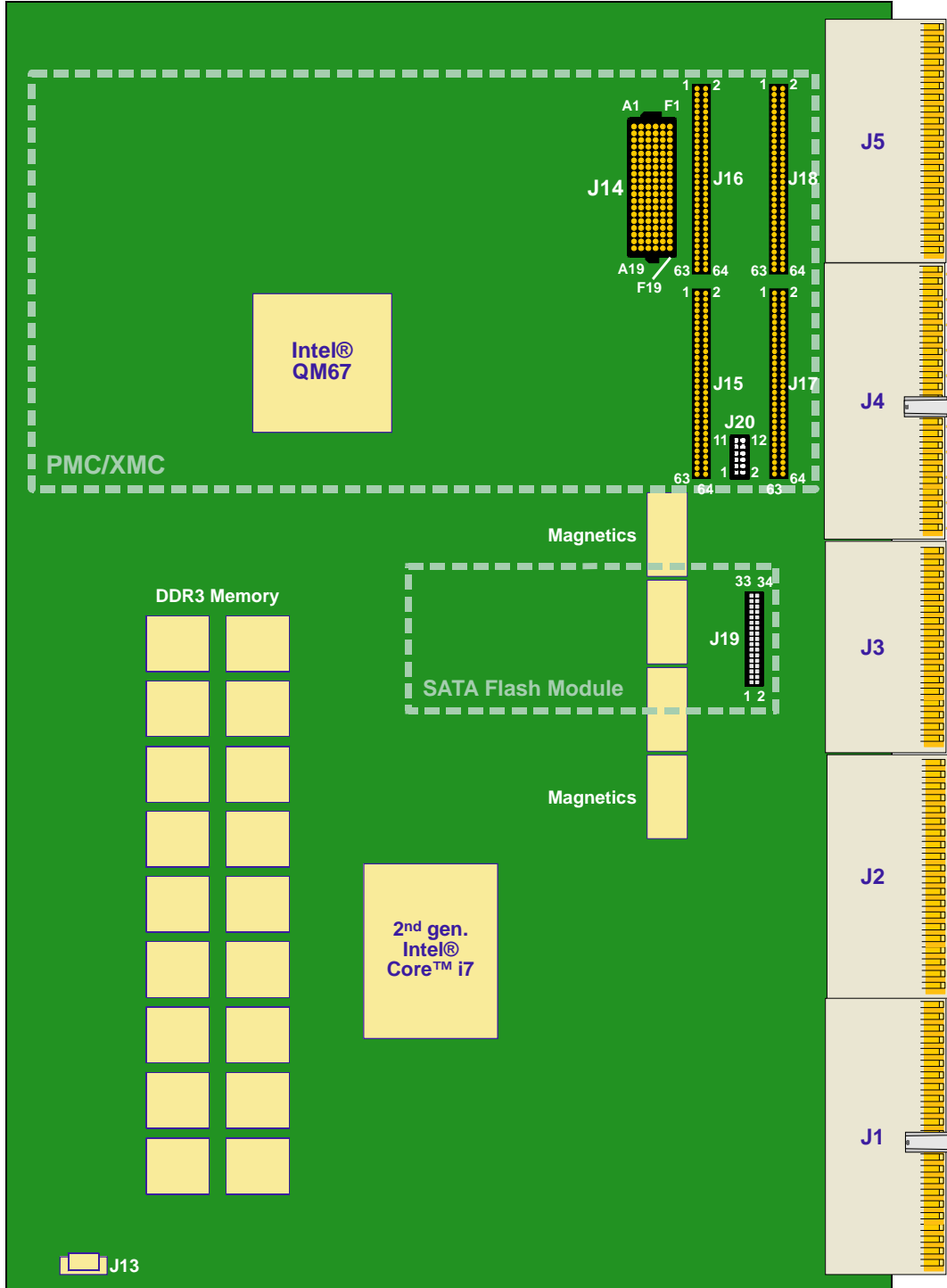



Figure 1-5: CP6003-RA Board Layout – Bottom View

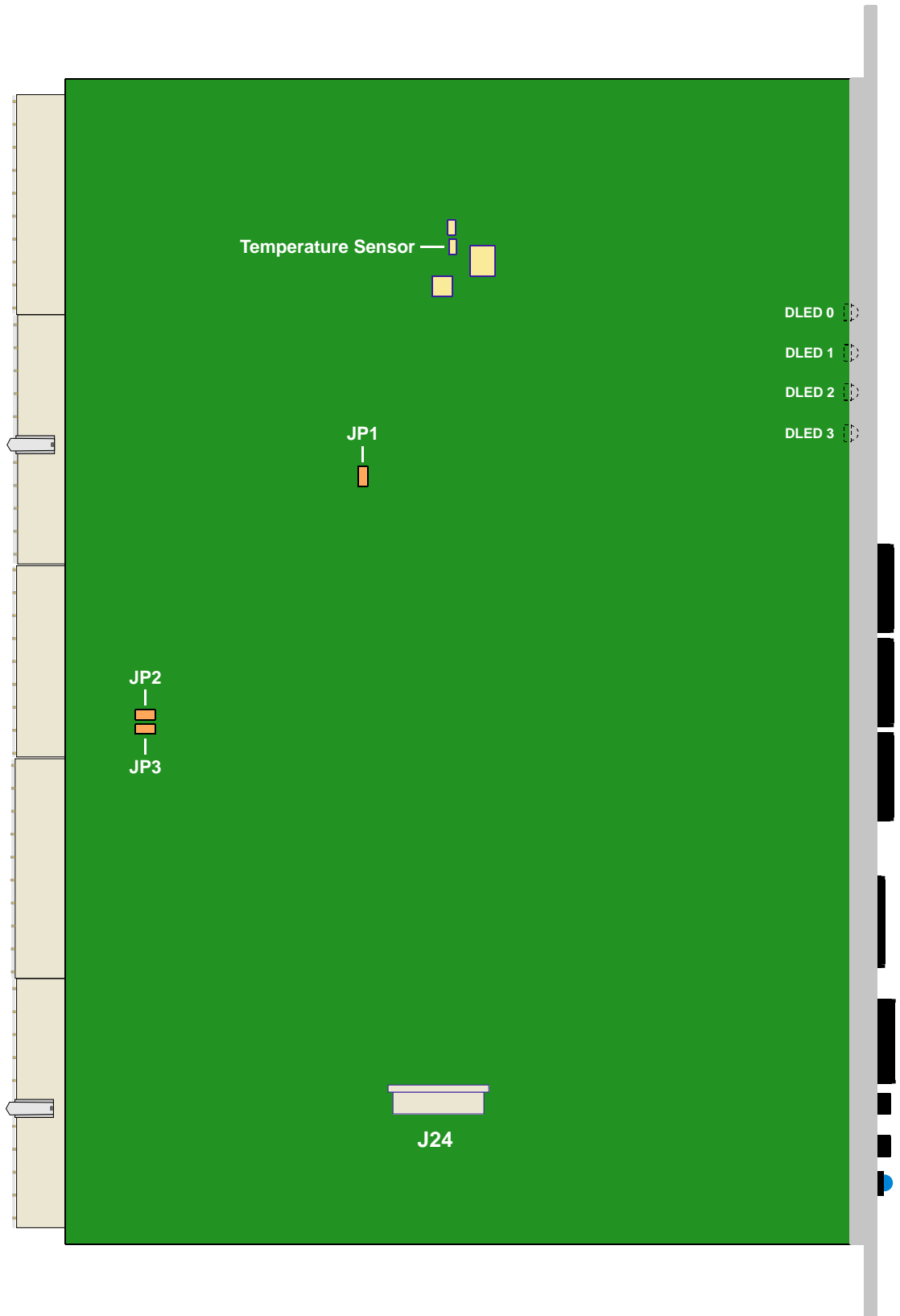



Figure 1-6: CP6003-RC Board Layout – Bottom View







## 1.7 Technical Specification

Table 1-2: CP6003-RA/RC Main Specifications

FEATURES		SPECIFICATIONS
Processor and Memory	CPU	<p>The CP6003-RA/RC supports the following 2<sup>nd</sup> generation microprocessors:</p> <ul style="list-style-type: none"> <li>• Quad-core Intel® Core™ i7-2715QE (SV), 2.1 GHz, 6 MB L3 cache</li> <li>• Dual-core Intel® Core™ i7-2655LE (LV), 2.2 GHz, 4 MB L3 cache</li> </ul> <p>Further processor features:</p> <ul style="list-style-type: none"> <li>• Up to four execution cores</li> <li>• Intel® Hyper-Threading Technology (Intel® HT Technology)</li> <li>• Intel® 64 Architecture</li> <li>• Intel® Advanced Vector Extensions (AVX) floating point</li> <li>• Intel® Turbo Boost Technology 2.0</li> <li>• Intel® Intelligent Power Sharing (IPS)</li> <li>• System memory interface with optimized support for dual-channel DDR3 SDRAM memory at 1333 MHz with ECC</li> <li>• Integrated 2D and 3D Graphics Engines</li> <li>• DMI 2.0 with 5 GT/s and FDI interfaces to the Intel® QM67 chipset</li> <li>• One x8 and two x4 PCI Express 2.0 ports operating at 5 GT/s</li> </ul> <p>Please contact Kontron for further information concerning the suitability of other Intel processors for use with the CP6003-RA/RC.</p>
	Memory	<p>Main Memory:</p> <ul style="list-style-type: none"> <li>• Up to 16 GB, dual-channel, soldered DDR3 SDRAM memory with ECC running at 1333 MHz</li> </ul> <p>Cache Structure:</p> <ul style="list-style-type: none"> <li>• 64 kB L1 cache for each core                             <ul style="list-style-type: none"> <li>• 32 kB instruction cache</li> <li>• 32 kB data cache</li> </ul> </li> <li>• 256 kB L2 shared instruction/data cache for each core</li> <li>• Up to 6 MB L3 shared instruction/data cache</li> </ul> <p>Flash Memory:</p> <ul style="list-style-type: none"> <li>• Two SPI flashes (2 x 8 MB) for uEFI BIOS and controlled by the IPMI controller</li> <li>• Up to 32 GB NAND flash via an onboard Serial ATA Flash module (SSD)</li> </ul> <p>Serial EEPROM with 64 kbit</p>

Table 1-2: CP6003-RA/RC Main Specifications (Continued)

FEATURES		SPECIFICATIONS
Chipset	Intel® QM67	<p>Mobile Intel® QM67 Express Chipset:</p> <ul style="list-style-type: none"> <li>• Two x4 or eight x1 PCI Express 2.0 ports operating at 5 GT/s (only one x4 PCI Express port is used on the CP6003-RA/RC)</li> <li>• SATA host controller with five ports and RAID 0/1/5/10 support <ul style="list-style-type: none"> <li>• One SATA 6 Gb/s ports accessible via an onboard connector</li> <li>• Four SATA 3 Gb/s ports accessible via rear I/O</li> </ul> </li> <li>• USB 2.0 host interface with up to 14 USB ports available (only six ports are used on the CP6003-RA/RC)</li> <li>• Integrated Ethernet controller</li> <li>• SPI flash interface support</li> <li>• Low Pin Count (LPC) interface</li> <li>• Power management logic support</li> <li>• Enhanced DMA controller, interrupt controller, and timer functions</li> <li>• System Management Bus (SMBus) compatible with most I<sup>2</sup>C™ devices</li> <li>• DMI 2.0 with 5 GT/s and FDI interfaces to the processor</li> <li>• High Definition Audio (HDA) interface</li> <li>• Analog display port</li> <li>• Three digital display ports</li> <li>• Integrated RTC</li> </ul>
Integrated Controller	Graphics controller	<p>High-performance 3D graphics controller integrated in the processor:</p> <ul style="list-style-type: none"> <li>• Support for two independent displays</li> <li>• Supports analog displays (CRT) up to a resolution of 2048 x 1536 pixels with 32-bit color @ 75 Hz</li> <li>• Supports digital displays (HDMI/DVI) up to a resolution of 1920 x 1200 pixels @ 60 Hz</li> <li>• Supports digital display (DP) up to a resolution of 2560 x 1600 pixels @ 60 Hz</li> <li>• Dynamic Video Memory Technology (DVMT)</li> </ul>
Interfaces	CompactPCI	<p>Compliant with the CompactPCI Specification PICMG 2.0 R 3.0:</p> <ul style="list-style-type: none"> <li>• System controller operation</li> <li>• 64-bit/66 MHz PCI or PCI-X master interface with dedicated PCIe-to-PCI-X bridge</li> <li>• 3.3V or 5V signaling levels (universal signaling support)</li> </ul> <p>Compliant with the Packet Switching Specification PICMG 2.16.</p> <p>The CP6003-RA/RC supports System Master hot swap functionality and application-dependent hot swap functionality when used in a peripheral slot.</p> <p>When used as a System Master, the CP6003-RA/RC supports individual clocks for each slot and the ENUM signal handling is in compliance with the PICMG 2.1 Hot Swap Specification.</p> <p>When installed in a peripheral slot, the CP6003-RA/RC is isolated from the CompactPCI bus. It receives power from the backplane and supports rear I/O and, if the system supports it, packet switching (in this case up to two channels of Gigabit Ethernet).</p>

**Table 1-2: CP6003-RA/RC Main Specifications (Continued)**

FEATURES		SPECIFICATIONS
Interfaces	Rear I/O	<p>The following interfaces are routed to the rear I/O connectors J3 and J5.</p> <ul style="list-style-type: none"> <li>• COMA (RS-232 signaling) and COMB (RS-422/RS-232 signaling); no buffer on the rear I/O module is necessary</li> <li>• 4 x USB 2.0</li> <li>• 1 x CRT VGA, 2 x HDMI/DVI</li> <li>• 1 x HDA</li> <li>• 2 x Gigabit Ethernet (compliant with PICMG 2.16, R 1.0)</li> <li>• 2 x Gigabit Ethernet</li> <li>• 4 x SATA 3 Gb/s</li> <li>• 4 x GPIs and 4 x GPOs (LVTTTL signaling)</li> </ul> <p>The rear I/O connector J4 provides rear I/O interconnection to the PMC/XMC interface.</p>
	Gigabit Ethernet	<p>Up to five 10 Base-T/100 Base-TX/1000 Base-T Gigabit Ethernet interfaces based on one Intel® 82579LM Gigabit Ethernet controller and one Intel® 82580EB Quad Gigabit Ethernet controller:</p> <ul style="list-style-type: none"> <li>• Three RJ-45 connectors on the front panel (CP6003-RA)</li> <li>• Two ports switchable between front I/O and to rear I/O (CP6003-RA)</li> <li>• Two Gigabit Ethernet interfaces on rear I/O with disable option in uEFI BIOS (CP6003-RC)</li> <li>• Two ports on the rear I/O (PICMG 2.16)</li> <li>• Automatic mode recognition (Auto-Negotiation)</li> <li>• Automatic cabling configuration recognition (Auto-MDI/X)</li> </ul>
	USB	<p>Up to six USB ports supporting UHCI (USB 1.1) and EHCI (USB 2.0):</p> <ul style="list-style-type: none"> <li>• Two type A USB 2.0 connectors on the front panel (CP6003-RA)</li> <li>• Four USB 2.0 ports on the rear I/O interface</li> </ul>
	Serial	<p>The CP6003-RA provides two 16C550-compatible UARTs :</p> <ul style="list-style-type: none"> <li>• One RS-232 port either on the front panel or on the rear I/O, COMA</li> <li>• One RS-422/RS-232 port on the rear I/O, COMB</li> </ul> <p>The CP6003-RC provides two 16C550-compatible UARTs :</p> <ul style="list-style-type: none"> <li>• One RS-232 port on the rear I/O, COMA</li> <li>• One RS-422/RS-232 port on the rear I/O, COMB</li> </ul>
	PMC	<p>PMC interface:</p> <ul style="list-style-type: none"> <li>• Four onboard mezzanine connectors, (Jn1-Jn4), for connecting a PMC module</li> <li>• Up to 64-bit/66 MHz PCI or up to 64-bit/133 MHz PCI-X interface with dedicated PCIe-to-PCI-X bridge</li> <li>• Only 3.3V PCI signaling voltage</li> <li>• Rear I/O supported through the CompactPCI connector J4</li> <li>• Supported voltages: 3.3 V, 5 V, +12 V, and -12 V</li> <li>• Support for PMC modules (CP6003-RA)</li> <li>• Support for CCPMC modules (CP6003-RC)</li> </ul>
	XMC	<p>XMC interface:</p> <ul style="list-style-type: none"> <li>• One onboard XMC connector (P15)</li> <li>• Up to x8 lanes PCI Express 2.0 ports operating at 5 GT/s</li> <li>• Rear I/O supported through the PMC connector (Jn4) to the CompactPCI connector J4</li> <li>• Support for XMC modules (CP6003-RA)</li> <li>• Support for conductive-cooled XMC modules (CP6003-RC)</li> </ul>

**Table 1-2: CP6003-RA/RC Main Specifications (Continued)**

FEATURES		SPECIFICATIONS
Interfaces	Serial ATA	<p>One Serial ATA 6 Gb/s interfaces for:</p> <ul style="list-style-type: none"> <li>One onboard SATA 6 Gb/s interface for the Serial ATA Flash module (up to 32 GB flash memory)</li> </ul> <p>Four SATA 3 Gb/s ports accessible via rear I/O</p>
Sockets	Front Panel Connectors (CP6003-RA)	<ul style="list-style-type: none"> <li>DP: one 20-pin DisplayPort connector, J9</li> <li>USB: two 4-pin, type A connectors, J6 and J7</li> <li>Ethernet: three 8-pin, RJ-45 connectors, J10, J11 and J12</li> <li>Serial port: one 8-pin, RJ-45 connector, J8 (COMA)</li> <li>PMC/XMC front panel bezel cutout</li> </ul>
	Onboard Connectors	<ul style="list-style-type: none"> <li>PMC connectors J15 - J18 (Jn1 - Jn4)</li> <li>XMC connector, J14</li> <li>One 34-pin, SATA extension connector, J19</li> <li>JTAG connector, J20</li> <li>Debug connector, J22</li> <li>XDP-SFF (debug) connector, J24</li> <li>CompactPCI Connectors J1 - J5</li> </ul>
Switches	DIP Switches (CP6003-RA)	Three onboard DIP switches, SW1, SW2, and SW3, for board configuration
	Reset Switch (CP6003-RA)	One front panel hardware reset switch
	Hot Swap Switch (CP6003-RA)	One switch for hot swap purposes integrated in the front panel handle in accordance with PICMG 2.1 Rev. 2.0.
LEDs	System LEDs	<p>System Status LEDs on the CP6003-RA:</p> <ul style="list-style-type: none"> <li>I0/I1 (red/green): Indicate the software status of the IPMI controller</li> <li>WD (green): Watchdog Status</li> <li>TH (red/green): Temperature Status</li> <li>HS (blue): Hot Swap Control</li> </ul> <p>System Status LEDs on the CP6003-RC:</p> <ul style="list-style-type: none"> <li>I0/I1 (red/green): Indicate the software status of the IPMI controller (located on the rear side of the board)</li> </ul> <p>Debug LEDs (CP6003-RA/RC):</p> <ul style="list-style-type: none"> <li>DLED0-3 (red/green): Onboard LEDs for debugging purposes (located on the rear side of the board)</li> </ul>
	Ethernet LEDs (CP6003-RA)	<p>Gigabit Ethernet Status:</p> <ul style="list-style-type: none"> <li>ACT (green): Ethernet Link/Activity</li> <li>SPEED (green/orange/off): Ethernet Speed</li> </ul>



Table 1-2: CP6003-RA/RC Main Specifications (Continued)

FEATURES		SPECIFICATIONS
Timer	Watchdog Timer	<ul style="list-style-type: none"> <li>• Software-configurable, two-stage Watchdog with programmable timeout ranging from 125 ms to 4096 s in 16 steps</li> <li>• Serves for generating IRQ or hardware reset</li> </ul>
	System Timer	<ul style="list-style-type: none"> <li>• The Intel® QM67 chipset contains three 8254-style counters which have fixed uses</li> <li>• In addition to the three 8254-style counters, the Intel® QM67 chipset includes eight individual high-precision event timers that may be used by the operating system. They are implemented as a single counter each with its own comparator and value register.</li> </ul>
IPMI	IPMI Controller	<ul style="list-style-type: none"> <li>• NXP® ARM7 microcontroller with redundant 512 kB firmware flash and automatic roll-back strategy</li> <li>• The IPMI controller carries out IPMI commands such as monitoring several onboard temperature conditions, board voltages and the power supply status, and managing hot swap operations.</li> <li>• The IPMI controller is accessible via two IPMBs (through the J1 and J2 connectors) and one host Keyboard Controller Style (KCS) interface.</li> </ul>
Thermal	Thermal Management	<p>CPU and board overtemperature protection is provided by:</p> <ul style="list-style-type: none"> <li>• Temperature sensors integrated in the 2<sup>nd</sup> gen. Intel® Core™ i7 processor: <ul style="list-style-type: none"> <li>• One temperature sensor for monitoring each processor core</li> <li>• One temperature sensor for monitoring the graphics core</li> <li>• One temperature sensor for monitoring the package die temperature</li> </ul> </li> <li>• One temperature sensor integrated in the Intel® QM67 chipset for monitoring the chipset</li> <li>• One onboard temperature sensor for monitoring the board temperature</li> <li>• Specially designed heat sink</li> </ul>
Security	TPM	Trusted Platform Module (TPM) 1.2 for enhanced hardware- and software-based data and system security (on request)

**Table 1-2: CP6003-RA/RC Main Specifications (Continued)**

FEATURES		SPECIFICATIONS
Software	uEFI BIOS	AMI Aptio®, AMI's next-generation BIOS firmware based on the uEFI Specification and the Intel Platform Innovation Framework for EFI. <ul style="list-style-type: none"> <li>• LAN boot capability for diskless systems (standard PXE)</li> <li>• Automatic fail-safe recovery in case of a damaged image</li> <li>• Non-volatile storage of setting in the SPI flash (battery only required for the RTC)</li> <li>• Compatibility Support Module (CSM) providing legacy BIOS compatibility based on AMIBIOS8</li> <li>• Command shell for diagnostics and configuration</li> <li>• uEFI Shell commands executable from mass storage device in a Pre-OS environment (open interface)</li> <li>• IPMI support in the command shell</li> </ul>
	Software IPMI	IPMI firmware providing the following features: <ul style="list-style-type: none"> <li>• The IPMI controller is accessible via up to two IPMBs, IOL and one KCS interface with interrupt support</li> <li>• The IPMI firmware can be updated in field through all supported interfaces using the function "fwum..." of the open-source tool "ipmitool". For further information on the ipmitool refer to the sourceforge.net website.</li> <li>• Two IPMI controller flash banks with automatic roll-back capability in case of an upgrade firmware failure</li> <li>• Board supervision and control extensions such as board reset, power and SPI flash control, etc.</li> </ul>
	Operating Systems	The board is offered with various Board Support Packages including Windows, VxWorks and Linux operating systems. For further information concerning the operating systems available for the CP6003-RA/RC, please contact Kontron.

Table 1-2: CP6003-RA/RC Main Specifications (Continued)

FEATURES		SPECIFICATIONS
General	Mechanical	6U, 4HP, CompactPCI-compliant form factor
	Power Consumption	See Chapter 5 for details.
	Temperature Ranges	<p>Operational temperature of CP6003-RA without TPM (with forced airflow):</p> <ul style="list-style-type: none"> <li>CP6003-RA with Core™ i7-2715QE (SV): -40°C to +55°C</li> <li>CP6003-RA with Core™ i7-2655LE (LV): -40°C to +70°C</li> </ul> <p>Operational temperature of CP6003-RC without TPM:</p> <ul style="list-style-type: none"> <li>Card edge temperature of CP6003-RC with Core™ i7-2715QE (SV) at the maximum frequency of 2.1 GHz: -40°C to + 60°C</li> <li>Card edge temperature of CP6003-RC with Core™ i7-2715QE (SV) at a reduced frequency of 1.7 GHz: -40°C to + 80°C</li> <li>Card edge temperature of CP6003-RC with Core™ i7-2655LE (LV) at the maximum frequency of 2.2 GHz: -40°C to + 75°C</li> <li>Card edge temperature of CP6003-RC with Core™ i7-2655LE (LV) at a reduced frequency of 1.7 GHz: -40°C to + 85°C</li> </ul> <p>Operational temperature of TPM: -25°C to +70°C</p> <p>Storage temperature of CP6003-RA without hard disk and without battery: -40°C to +85°C</p> <p>Storage temperature of CP6003-RC without hard disk and without battery: -55°C to +105°C</p> <p> <b>Note ...</b> When a battery is installed, refer to the operational specifications of the battery as this determines the storage temperature of the CP6003-RA (See "Battery" below).</p> <p> <b>Note ...</b> When additional components are installed, refer to their operational specifications as this will influence the operational and storage temperature of the CP6003-RA/RC.</p>
	Battery (CP6003-RA)	<p>3.0V lithium battery for RTC with battery socket.</p> <p>Battery type: UL-approved CR2025</p> <p>Temperature ranges:</p> <p>Operational: -20°C to +70°C typical (refer to the battery manufacturer's specifications for exact range)</p> <p>Storage: -55°C to +70°C typical (no discharge)</p>
	Dimensions	233.35 mm x 160 mm
Board Weight	<p>CP6003-RA: 725 g (with heat sink but without mezzanine cards)</p> <p>CP6003-RC: 828 g (with heat sink but without mezzanine cards)</p>	

## 1.8 Standards

The CP6003-RA/RC complies with the requirements of the following standards:

**Table 1-3: Standards for the CP6003-RA**

TYPE	ASPECT	STANDARD	REMARKS
CE	Emission	EN55022 EN61000-6-3	--
	Immission	EN55024 EN61000-6-2	--
	Electrical Safety	EN60950-1	--
Mechanical	Mechanical Dimensions	IEEE1101.10	--
Environmental	Climatic Humidity	IEC60068-2-78	93% RH at 40°C, non-condensing <b>See note below.</b>
	WEEE	Directive 2002/96/EC	Waste electrical and electronic equipment
	RoHS	Directive 2002/95/EC	Restriction of the use of certain hazardous substances in electrical and electronic equipment
	Random Vibration (Broadband)	ANSI/VITA 47 (Class V2)	Test parameters: <ul style="list-style-type: none"> <li>• 5-100 (Hz) frequency range: +3dB slope</li> <li>• 100-1000 (Hz) freq. range: 0.04 (g<sup>2</sup>/Hz)</li> <li>• 1000-2000 (Hz) freq. range: -6dB slope</li> <li>• 7.619 g (rms)</li> <li>• 60 (min) test duration/axis</li> <li>• 3 axes</li> </ul>
	Single Shock	ANSI/VITA 47 (Class OS1)	Test parameters: <ul style="list-style-type: none"> <li>• 20 (g) acceleration</li> <li>• 11 (ms) shock duration half sine</li> <li>• 3 shocks per direction</li> <li>• 6 directions</li> <li>• 5 (s) recovery time</li> </ul>



### Note ...

Kontron performs comprehensive environmental testing of its products in accordance with applicable standards.

Customers desiring to perform further environmental testing of Kontron products must contact Kontron for assistance prior to performing any such testing. This is necessary, as it is possible that environmental testing can be destructive when not performed in accordance with the applicable specifications.

In particular, for example, boards **without conformal coating** must not be exposed to a change of temperature exceeding 1K/minute, averaged over a period of not more than five minutes. Otherwise, condensation may cause irreversible damage, especially when the board is powered up again.

Kontron does not accept any responsibility for damage to products resulting from destructive environmental testing.



Table 1-4: Standards for the CP6003-RC

TYPE	ASPECT	STANDARD	REMARKS
CE	Emission	EN55022 EN61000-6-3	--
	Immission	EN55024 EN61000-6-2	--
	Electrical Safety	EN60950-1	--
Mechanical	Mechanical Dimensions	ANSI/VITA 30.1	--
Environmental	Climatic Humidity	ANSI/VITA 47	95% RH at +30°C to +60°C, condensing
	WEEE	Directive 2002/96/EC	Waste electrical and electronic equipment
	RoHS	Directive 2002/95/EC	Restriction of the use of certain hazardous substances in electrical and electronic equipment
	Random Vibration (Broadband)	ANSI/VITA 47 (Class V3)	Test parameters: <ul style="list-style-type: none"> <li>• 5-100 (Hz) frequency range: +3dB slope</li> <li>• 100-1000 (Hz) freq. range: 0.1 (g<sup>2</sup>/Hz)</li> <li>• 1000-2000 (Hz) freq. range: -6dB slope</li> <li>• 12.05 g (rms)</li> <li>• 60 (min) test duration/axis</li> <li>• 3 axes</li> </ul>
	Single Shock	ANSI/VITA 47 (Class OS2)	Test parameters: <ul style="list-style-type: none"> <li>• 40 (g) acceleration</li> <li>• 11 (ms) shock duration half sine</li> <li>• 3 shocks per direction</li> <li>• 6 directions</li> <li>• 5 (s) recovery time</li> </ul>

## 1.9 Related Publications

The following publications contain information relating to this product.

**Table 1-5: Related Publications**

PRODUCT	PUBLICATION
CompactPCI Systems and Boards	CompactPCI Specification PICMG 2.0, Rev. 3.0 CompactPCI Packet Switching Backplane Specification PICMG 2.16 Rev. 1.0 CompactPCI System Management Specification PICMG 2.9 Rev. 1.0 CompactPCI Hot Swap Specification PICMG 2.1 Rev. 2.0
	IPMI - Intelligent Platform Management Interface Specification v2.0
	Kontron CompactPCI Backplane Manual, ID 24229
PMC Module	IEEE 1386-2001, IEEE Standard for a Common Mezzanine Card (CMC) Family IEEE 1386.1-2001, IEEE Standard Physical and Environmental Layers for PCI Mezzanine Cards (PMC)
XMC Module	ANSI/VITA 42.0-200x XMC Switched Mezzanine Card Auxiliary Standard ANSI/VITA 42.3-2006 XMC PCI Express Protocol Layer Standard
Platform Firmware	Unified Extensible Firmware Interface (UEFI) Specification, Version 2.1
All Kontron products	Product Safety and Implementation Guide, ID 1021-9142
Kontron	CP6003-RA/RC uEFI BIOS User Guide
	CP6003-RA/RC IPMI Firmware User Guide