

» Kontron User's Guide «

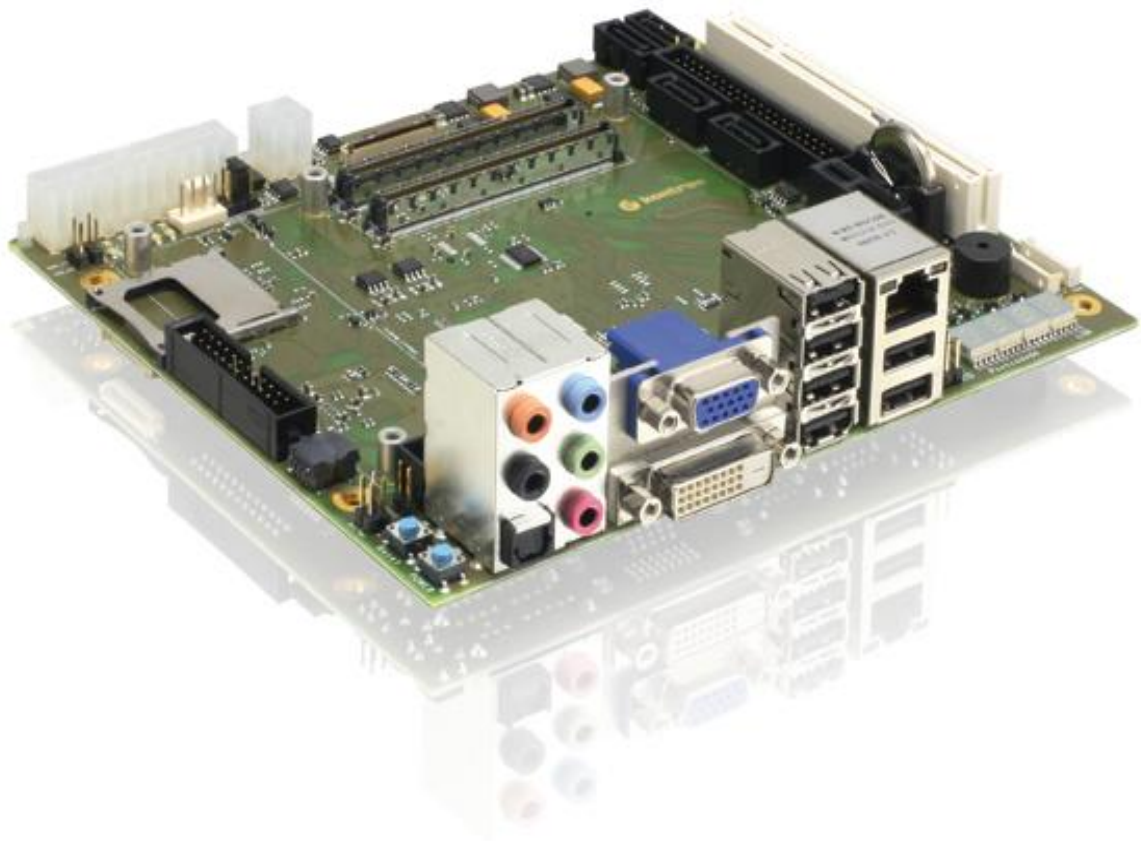

COM Express™ miniBaseboard Type 2

Document Revision 220

» Table of Contents «

1	User Information	1
1.1	About This Document	1
1.2	Copyright Notice	1
1.3	Trademarks	1
1.4	Standards	1
1.5	Warranty	2
1.6	Technical Support	2
2	Introduction	3
3	Specification	4
3.1	Functional Specification	4
3.2	Block Diagram	6
3.2.1	ETXexpress® miniBaseboard.....	6
3.2.2	COM Express™ miniBaseboard Type 2	7
3.3	Mechanical Specification	8
3.3.1	ETXexpress® miniBaseboard.....	8
3.3.2	COM Express™ miniBaseboard Type 2	9
3.4	Electrical Specification	10
3.5	Environmental Specification	11
3.6	MTBF	11
4	Connector Layout	12
4.1	Back Panel.....	12
4.2	Connector Locations	13
4.2.1	ETXexpress® miniBaseboard top view	13
4.2.2	ETXexpress® miniBaseboard bottom view	15
4.2.3	ETXexpress® miniBaseboard connector overview	17
4.2.4	COM Express™ miniBaseboard Type 2 top view	19
4.2.5	COM Express™ miniBaseboard Type 2 bottom view	21
4.2.6	COM Express™ miniBaseboard Type 2 connector overview	23

5	Connectors and Features	24
5.1	Power supply.....	24
5.1.1	ATX connector	24
5.1.2	PS_ON override	25
5.1.3	Reset and Power button.....	26
5.2	COM Express™ connector.....	27
5.3	Status LED	28
5.4	Serial ATA	29
5.5	IDE and Compact Flash	30
5.6	SD-Card.....	32
5.7	High Definition Audio	33
5.7.1	Front Panel and internal connectors.....	33
5.7.2	Onboard Speaker	35
5.8	Ethernet.....	36
5.9	USB.....	37
5.10	PCI.....	38
5.11	PCIexpress and Express Card	39
5.12	Kontron Feature connector.....	40
5.13	DVI and VGA	42
5.14	LVDS	43
5.15	TV-Out	44
5.16	External BIOS	45
5.17	CPLD & POST-Code Display.....	46
5.18	Winbond 83627 Super-I/O	48
5.18.1	RS232	49
5.18.2	LPT	50
5.18.3	FAN.....	51
5.18.4	Temp Sensor	52
5.19	FRU-PROM (I2C EEPROM).....	53
6	Battery Information	54
7	Single Supply Mode.....	56

7.1	Assembly Instructions ETXexpress® miniBaseboard	57
7.2	Assembly Instructions COM Express™ miniBaseboard Type 2	60
8	Power Distribution ETXexpress® miniBaseboard	63
9	Power Distribution COM Express™ miniBaseboard Type 2	64
10	Security Advice	65
11	Appendix C: Document Revision History.....	66

1 User Information

1.1 About This Document

This document provides information about products from Kontron Embedded Modules GmbH and/or its subsidiaries. No warranty of suitability, purpose, or fitness is implied. While every attempt has been made to ensure that the information in this document is accurate, the information contained within is supplied “as-is” and is subject to change without notice.

For the circuits, descriptions and tables indicated, Kontron assumes no responsibility as far as patents or other rights of third parties are concerned.

1.2 Copyright Notice

Copyright © 2003-2010 Kontron Embedded Modules GmbH

All rights reserved. No part of this document may be reproduced, transmitted, transcribed, stored in a retrieval system, or translated into any language or computer language, in any form or by any means (electronic, mechanical, photocopying, recording, or otherwise), without the express written permission of Kontron Embedded Modules GmbH.

DIMM-PC®, PISA®, ETX®, ETXexpress®, microETXexpress™, X-board®, DIMM-IO® and DIMM-BUS® are trademarks or registered trademarks of Kontron Embedded Modules GmbH. Kontron is trademark or registered trademark of Kontron AG.

1.3 Trademarks

The following lists the trademarks of components used in this board.

- » IBM, XT, AT, PS/2 and Personal System/2 are trademarks of International Business Machines Corp.
- » Microsoft is a registered trademark of Microsoft Corp.
- » Intel is a registered trademark of Intel Corp.
- » All other products and trademarks mentioned in this manual are trademarks of their respective owners.

1.4 Standards

Kontron Embedded Modules GmbH is certified to ISO 9000 standards.

1.5 Warranty

This Kontron Embedded Modules GmbH product is warranted against defects in material and workmanship for the warranty period from the date of shipment. During the warranty period, Kontron Embedded Modules GmbH will at its discretion decide to repair or replace defective products.

Within the warranty period, the repair of products is free of charge as long as warranty conditions are observed.

The warranty does not apply to defects resulting from improper or inadequate maintenance or handling by the buyer, unauthorized modification or misuse, operation outside of the product's environmental specifications or improper installation or maintenance.

Kontron Embedded Modules GmbH will not be responsible for any defects or damages to other products not supplied by Kontron Embedded Modules GmbH that are caused by a faulty Kontron Embedded Modules GmbH product.

1.6 Technical Support

Technicians and engineers from Kontron Embedded Modules GmbH and/or its subsidiaries are available for technical support. We are committed to making our product easy to use and will help you use our products in your systems.

Please consult our Web site at <http://www.kontron.com/support> for the latest product documentation, utilities, drivers and support contacts. Consult our customer section <http://emdcustomersection.kontron.com> for the latest BIOS downloads, Product Change Notifications and additional tools and software. In any case you can always contact your board supplier for technical support.

2 Introduction

The Kontron Type 2 miniBaseboard is an evaluation backplane for COM Express™ Computer-on-Modules following the PICMG COM.0 specification with pin-out Type 2. The baseboard is available as:

ETXexpress® miniBaseboard

- » PartNo. **38102-0000-00-0**
- » PICMG COM.0 Rev 1.0 baseboard for Type 2 modules

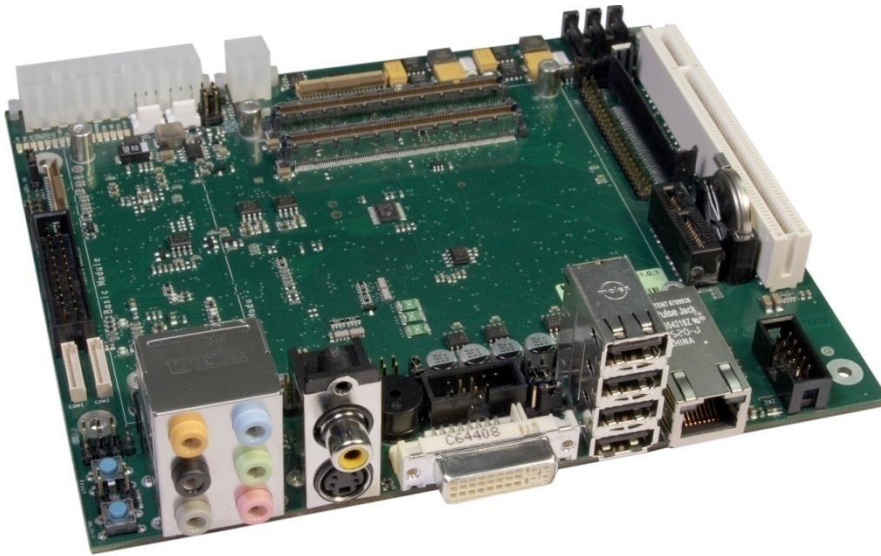

COM Express™ miniBaseboard Type 2

- » PartNo **38102-0000-00-1**
- » PICMG COM.0 Rev 2.0 baseboard for Type 2 modules



3 Specification

3.1 Functional Specification

Basic features

The basic feature set for both ETXexpress miniBaseboards includes most interfaces available on Computer-On-Modules such as:

- » PCI (1 Slot)
- » PCIexpress x1 (1 Slot)
- » 4 SATA
- » LPT (Winbond 83627 LPC-I/O)
- » RS232 (2 COM Ports, Winbond 83627 LPC-I/O)
- » VGA
- » DVI (SDV0toDVI converter)
- » LVDS (40pin JILI connector)
- » HD Audio
- » Express Card
- » LPC Firmware Hub for external boot

Additional features:

- » ATX EPS (20pin + 4pin) supply and Single voltage supply support
- » Kontron feature connector
- » Front panel connectors (HDD Act., Reset and Power Switch)
- » Status LED

ETXexpress® miniBaseboard

The ETXexpress miniBaseboard follows the PICMG COM.0 Rev 1.0 specification and additionally provides:

- » Ethernet RJ45 configurable as 10/100Mbit or 1000Mbit Ethernet
- » Hardware Monitor from Winbond 83627 LPC-I/O with 2 FAN and 3 thermal diode connectors
- » TV-Out: S-Video, component and composite
- » DVI-I connector with combined DVI and CRT output for single use
- » IDE (44pin) and Compact Flash Socket
- » 4 USB 2.0/1.1 Ports and 2 onboard USB pin header

COM Express™ miniBaseboard Type 2

The COM Express™ miniBaseboard Type 2 follows the PICMG COM.0 Rev 2.0 specification and additionally provides:

- » Ethernet RJ45 for 1000Mbit Ethernet
- » Hardware Monitor from Winbond 83627 LPC-I/O with PWM FAN
- » Separated DVI-D and CRT connector for Dual Display configurations
- » 1 IDE channel (40pin connector)
- » 6 USB 2.0/1.1 Ports and 1 onboard USB pin header for USB Client function
- » SD-Card Socket
- » SPI Flash for external boot (optional)
- » I2C EEPROM (optional)
- » 4 digit POST code display

3.2 Block Diagram

3.2.1 ETXexpress® miniBaseboard

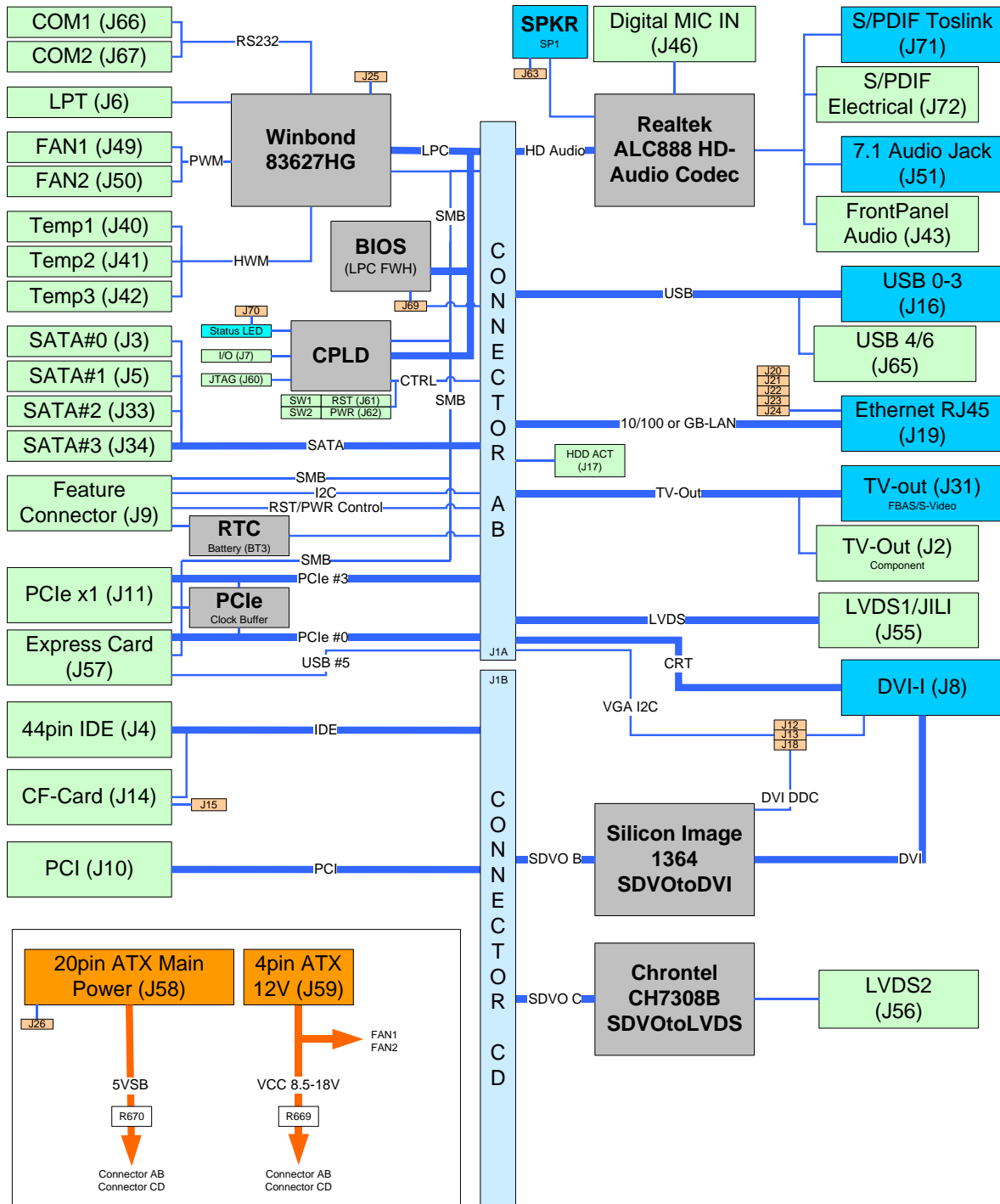

3.2.2 COM Express™ miniBaseboard Type 2

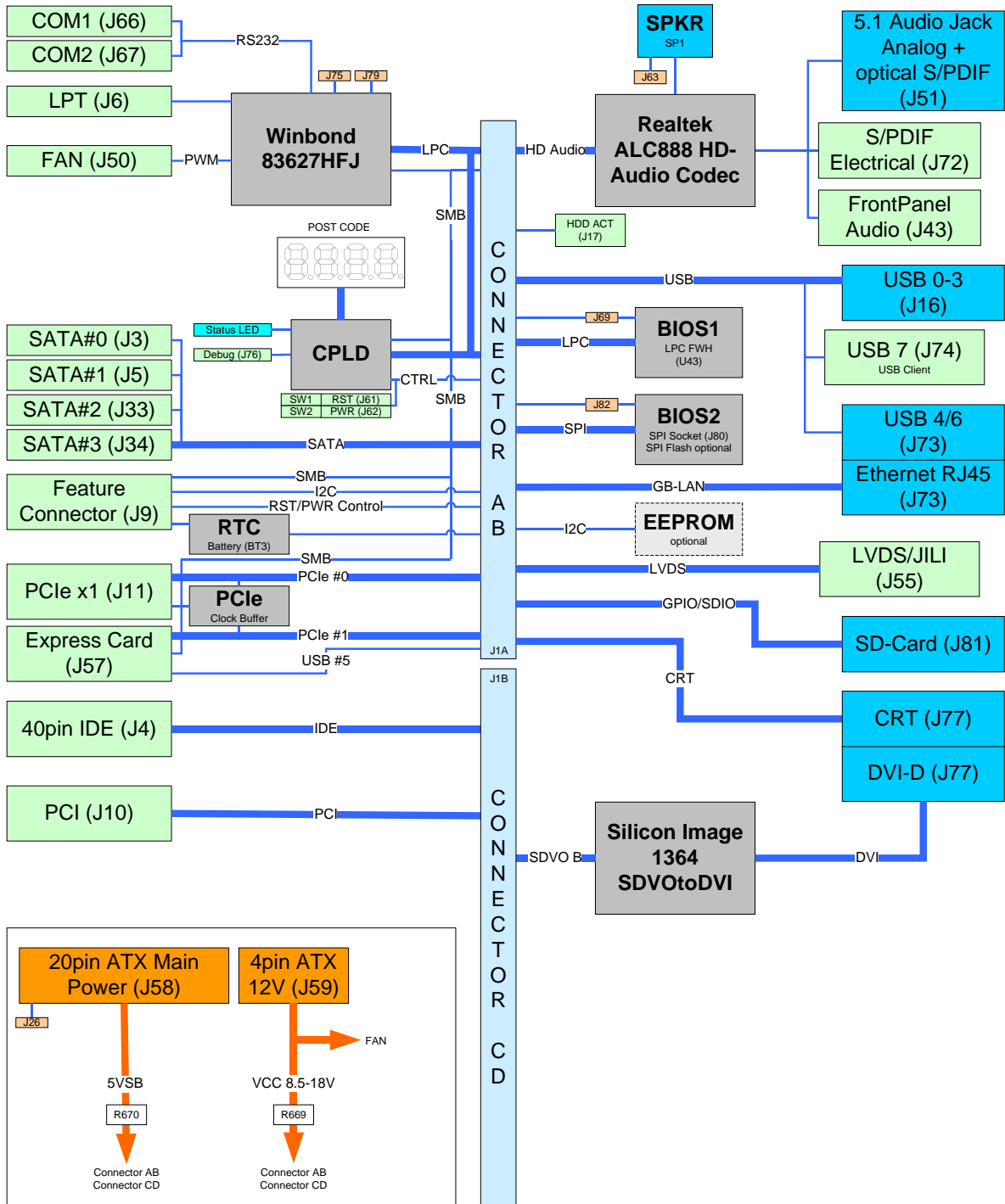

3.3 Mechanical Specification

Both baseboard revisions are 170x145mm in size with same location of mounting holes and module position. The connector placement is different. See detailed dimensions below.

3.3.1 ETXexpress® miniBaseboard

- » max height on top: 36.05mm (Connector J51)
- » PCB thickness: 1.92mm \pm 10%
- » max height on bottom: 5.40mm (Connector J57)

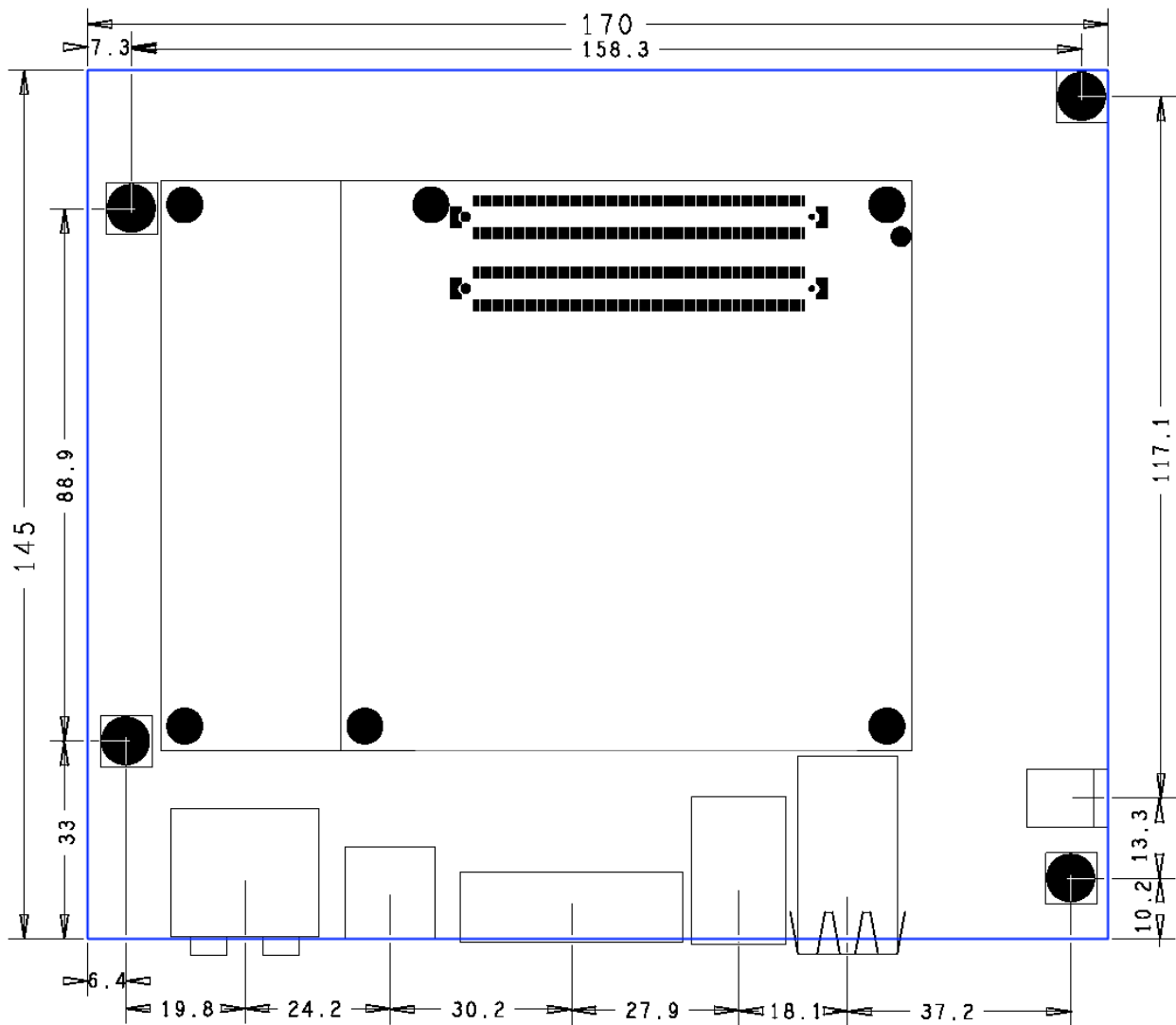

3.3.2 COM Express™ miniBaseboard Type 2

- » max height on top: 35.80mm (Connector J51)
- » PCB thickness: 1.92mm \pm 10%
- » max height on bottom: 5.40mm (Connector J57)
8.0mm (Rubber feet)

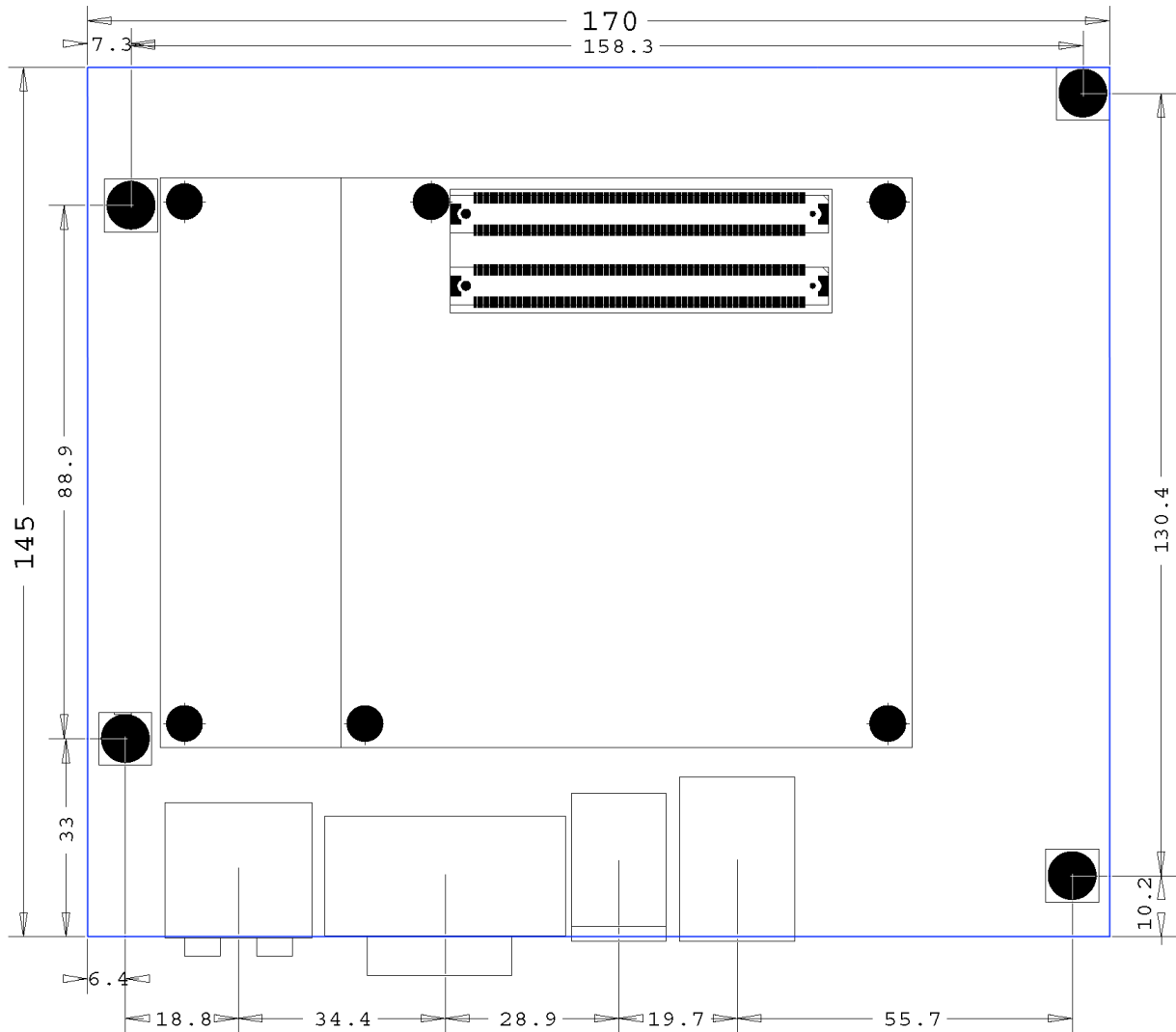

3.4 Electrical Specification

Supply Voltage

- » 12V + 5VSB $\pm 5\%$ in ATX mode
- » 8.5 V to 18 V DC in single supply mode

Power Supply Rise time

- » The input voltages shall rise from $\leq 10\%$ of nominal to within the regulation ranges within 0.1ms to 20ms.
- » There must be a smooth and continuous ramp of each DC input voltage from 10% to 90% of its final set-point following the ATX specification

Supply Voltage Ripple

- » Maximum 100 mV peak to peak 0-20MHz

3.5 Environmental Specification

Ambient temperature

- » Operating: 0 to +60 °C
- » Non-operating: -30 to +85 °C

Humidity

- » Operating: 10% to 90% (non condensing)
- » Non operating: 5% to 95% (non condensing)

3.6 MTBF

The following MTBF (Mean Time Between Failures) values were calculated using a combination of manufacturer's test data, if the data was available, and a Bellcore calculation for the remaining parts. The Bellcore calculation used is "Method 1 Case 1". In that particular method the components are assumed to be operating at a 50 % stress level in a 40° C ambient environment and the system is assumed to have not been burned in. Manufacturer's data has been used wherever possible. The manufacturer's data, when used, is specified at 50° C, so in that sense the following results are slightly conservative. The MTBF values shown below are for a 40° C in an office or telecommunications environment. Higher temperatures and other environmental stresses (extreme altitude, vibration, salt water exposure, etc.) lower MTBF values.

- » System MTBF ETXexpress® miniBaseboard: **192796** hours
- » System MTBF COM Express™ miniBaseboard Type 2: **144767** hours

4 Connector Layout

4.1 Back Panel

ETXexpress® miniBaseboard

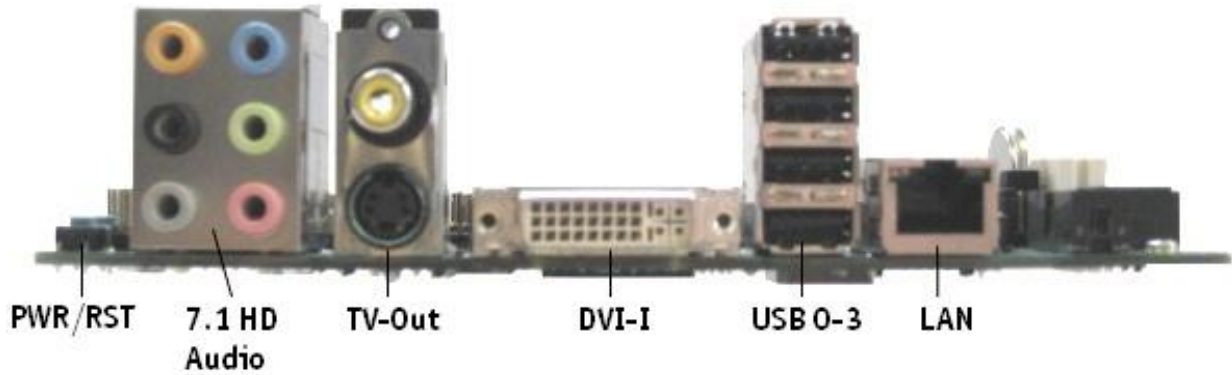

COM Express™ miniBaseboard Type 2

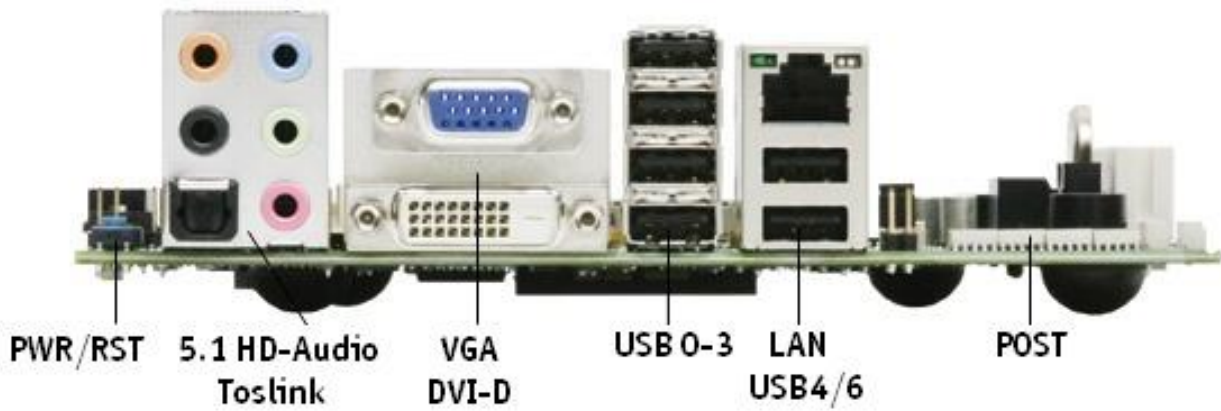

4.2 Connector Locations

4.2.1 ETXexpress® miniBaseboard top view

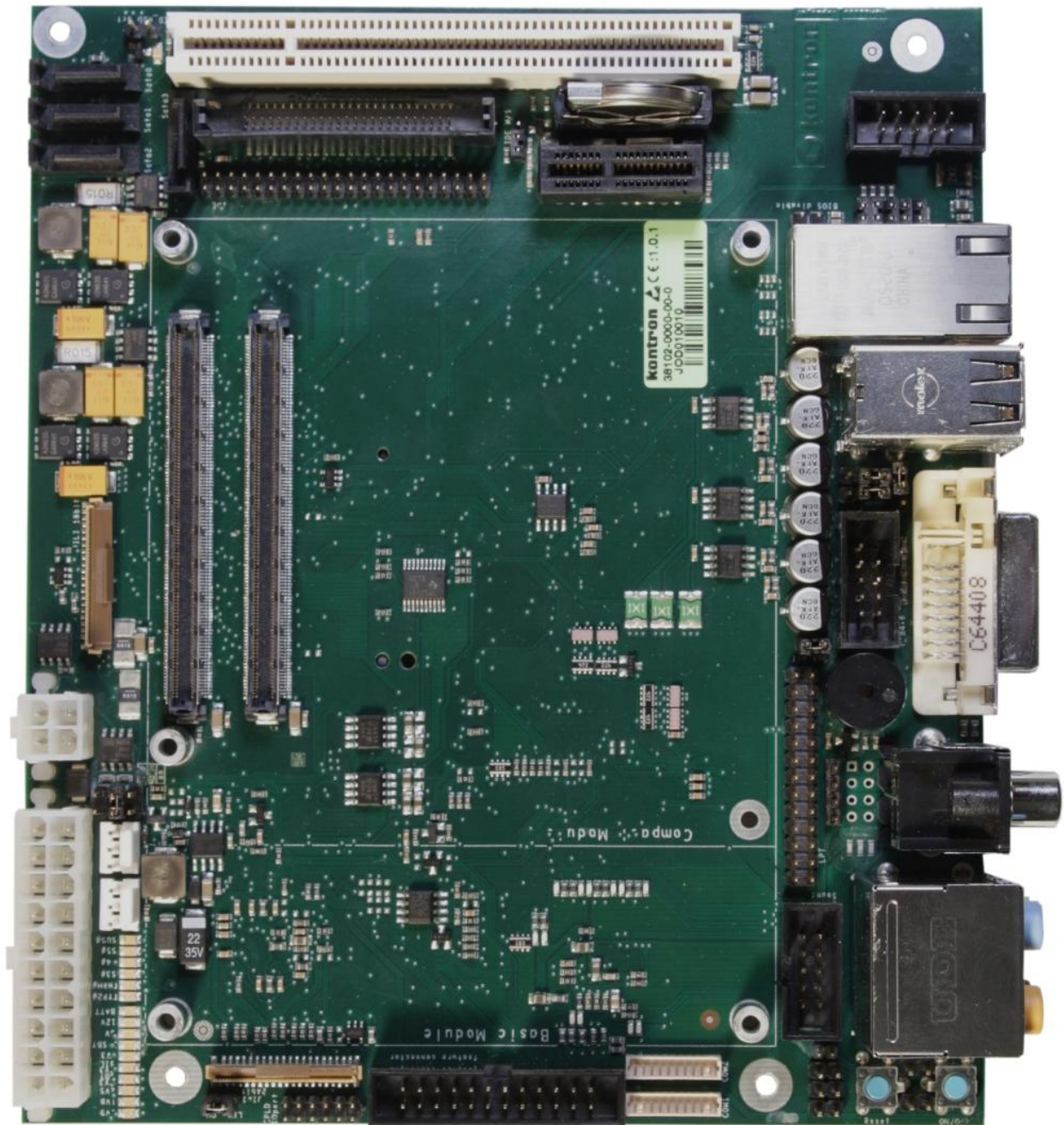

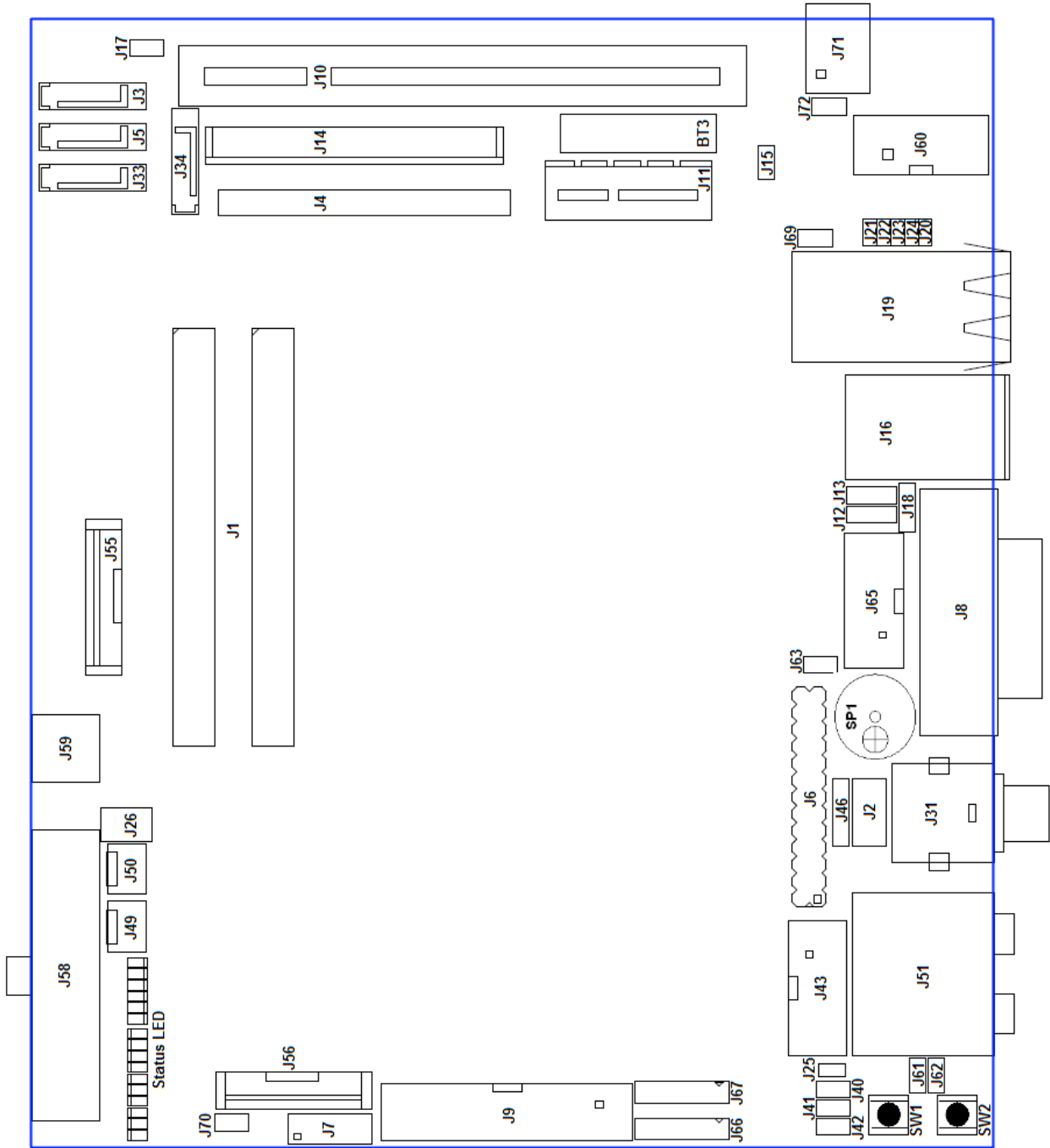

4.2.2 ETXexpress® miniBaseboard bottom view

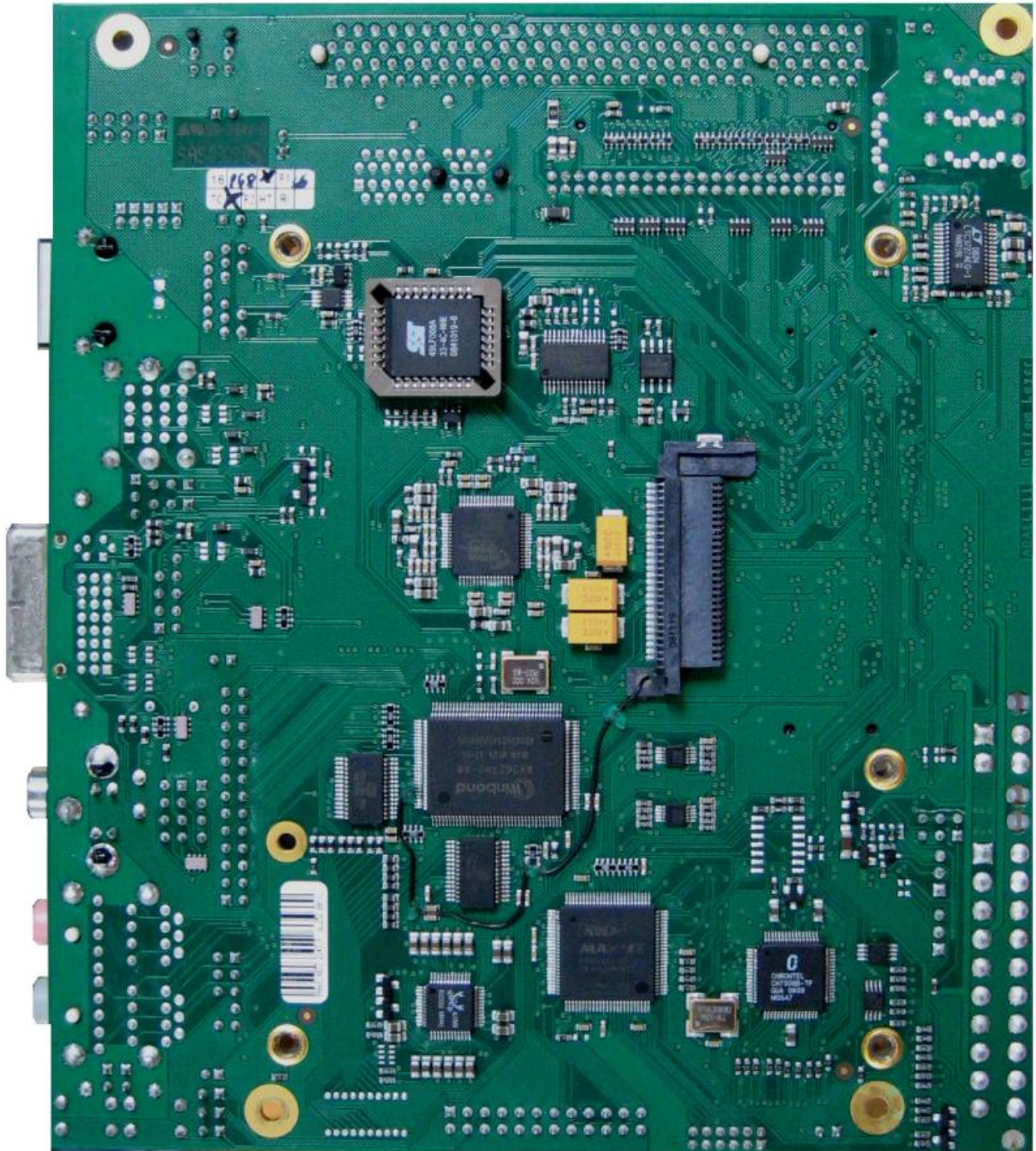

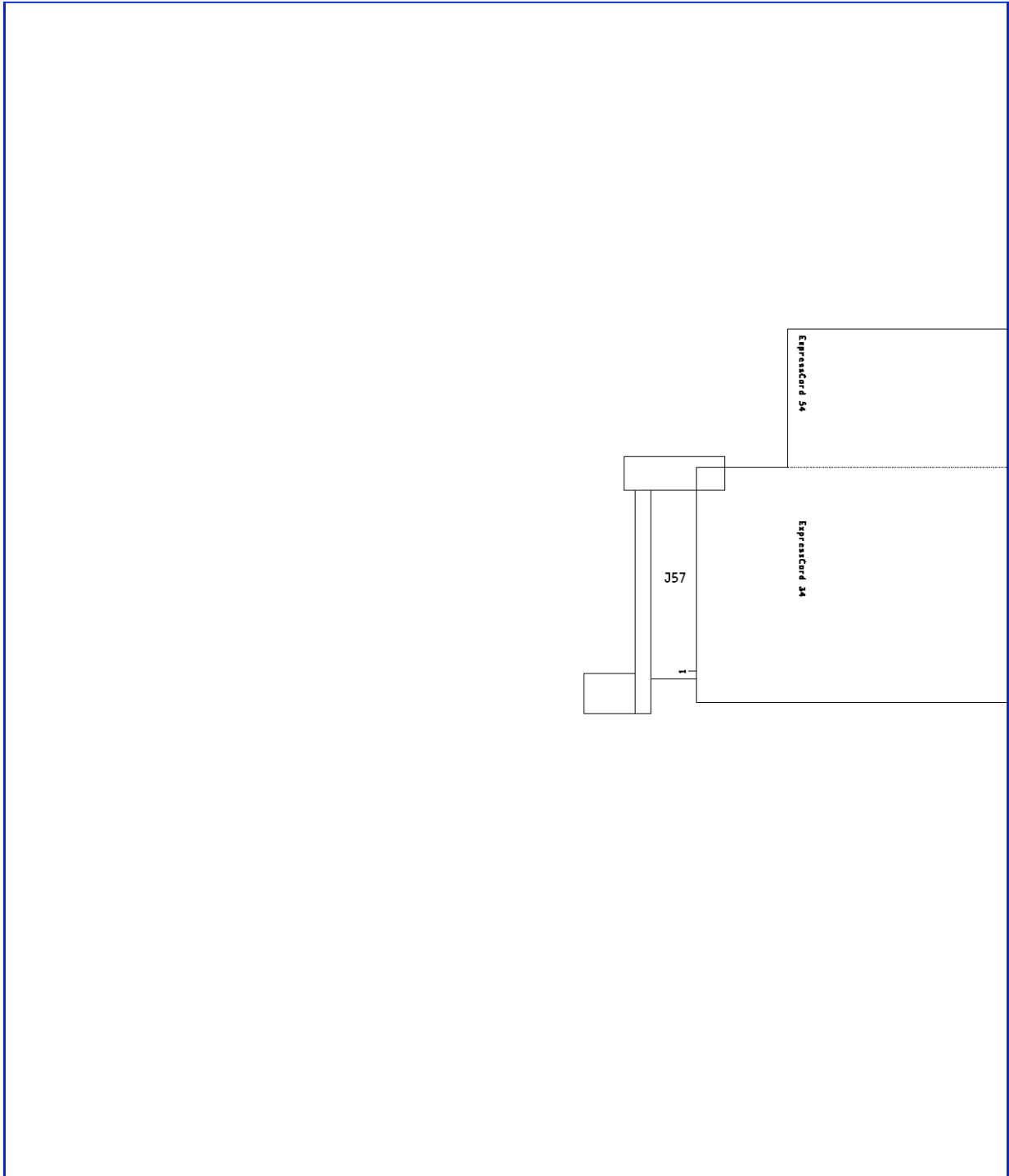

4.2.3 ETXexpress® miniBaseboard connector overview

Connector	Short Description
BT3	RTC Battery
J1	COM Express Connector
J2	Component Video
J3	SATA0
J4	Primary IDE
J5	SATA1
J6	LPT
J7	CPLD I/O Port (for internal use only)
J8	DVI-I Connector
J9	Kontron Feature Connector
J10	PCI Connector
J11	PCIexpress x1
J12	VGA/DVI I2C Data Selector
J13	VGA/DVI I2C Clock Selector
J14	Compact Flash Socket
J15	CF Card Master/Single
J16	USB Ports 0-3
J17	HDD Activity LED
J18	VGA/DVI DDC Power Selector
J19	RJ45 10/100 or GBit Ethernet Jack
J20	100MBit / GBit Ethernet Switch
J21	100MBit / GBit Ethernet Switch
J22	100MBit / GBit Ethernet Switch
J23	100MBit / GBit Ethernet Switch
J24	100MBit / GBit Ethernet Switch
J25	Onboard SIO Adress Switch
J26	ATX_PS_ON Override Jumper
J31	TV-Out Composite/S-Video
J33	SATA2
J34	SATA3
J40	Connector for external Temp Sensor 1
J41	Connector for external Temp Sensor 2
J42	Connector for external Temp Sensor 3
J43	Front Panel Audio Connector
J46	Digital Microphone In
J49	FAN Connector 1
J50	FAN Connector 2
J51	7.1 Analog HD Audio Connector
J55	JILI40 LVDS 1
J56	JILI40 LVDS 2
J57	Express Card Slot (on PCB's back side)
J58	ATX Main Power Connector
J59	ATX_12V Power Connector
J60	CPLD JTAG connector
J61	Front Panel Reset Switch

J62	Front Panel Power Switch
J63	Enable/Disable onboard Speaker
J65	USB4 & USB6 Pin Header
J66	COM1
J67	COM2
J69	Disable Module BIOS for booting from baseboard LPC FW
J70	Enable/Disable Status LEDs
J71	Optical S/PDIF out connector (Toslink)
J72	electrical S/PDIF out Pin header
SP1	Speaker
SW1	Reset Button
SW2	Power Button

4.2.4 COM Express™ miniBaseboard Type 2 top view

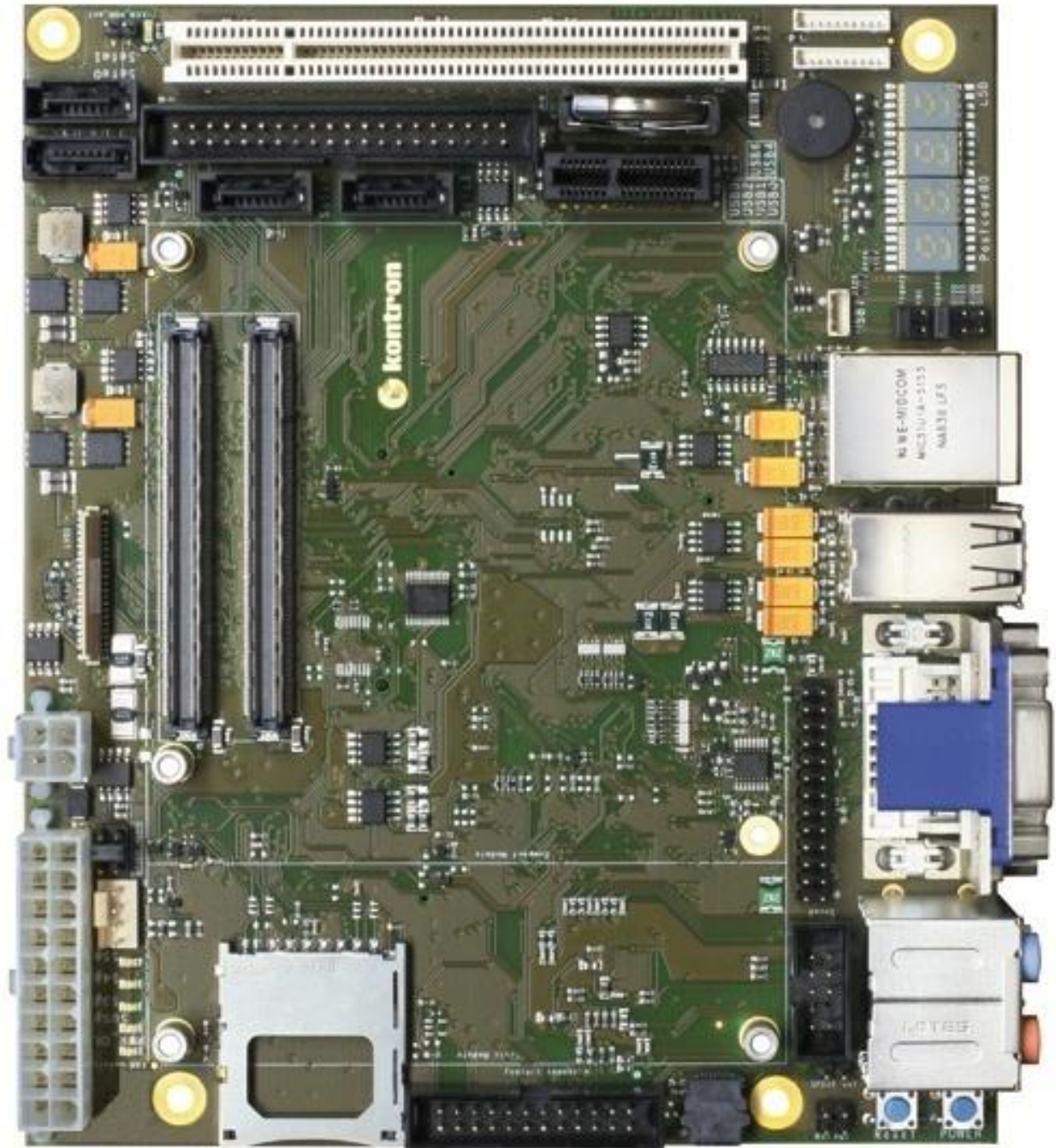

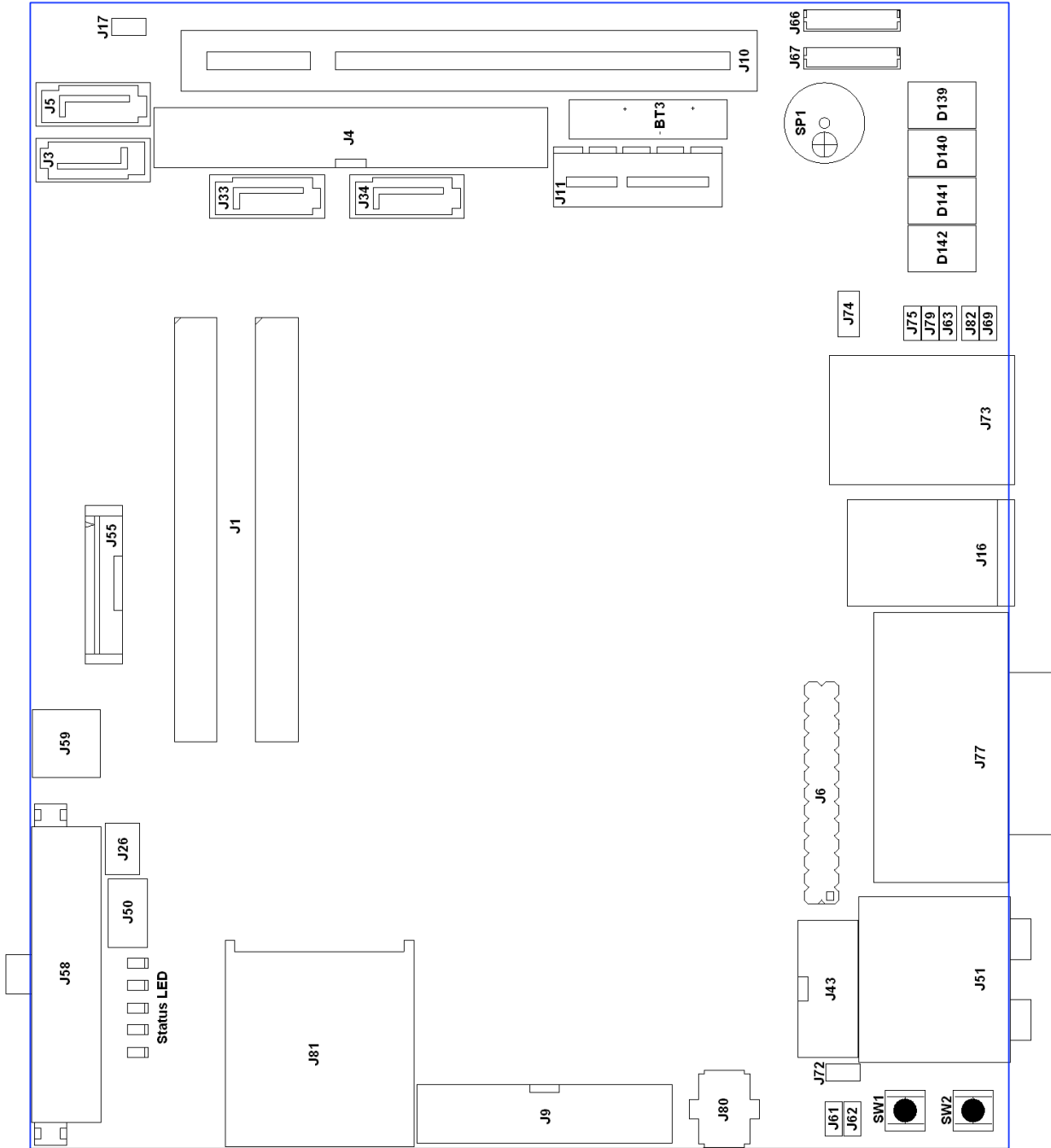

4.2.5 COM Express™ miniBaseboard Type 2 bottom view



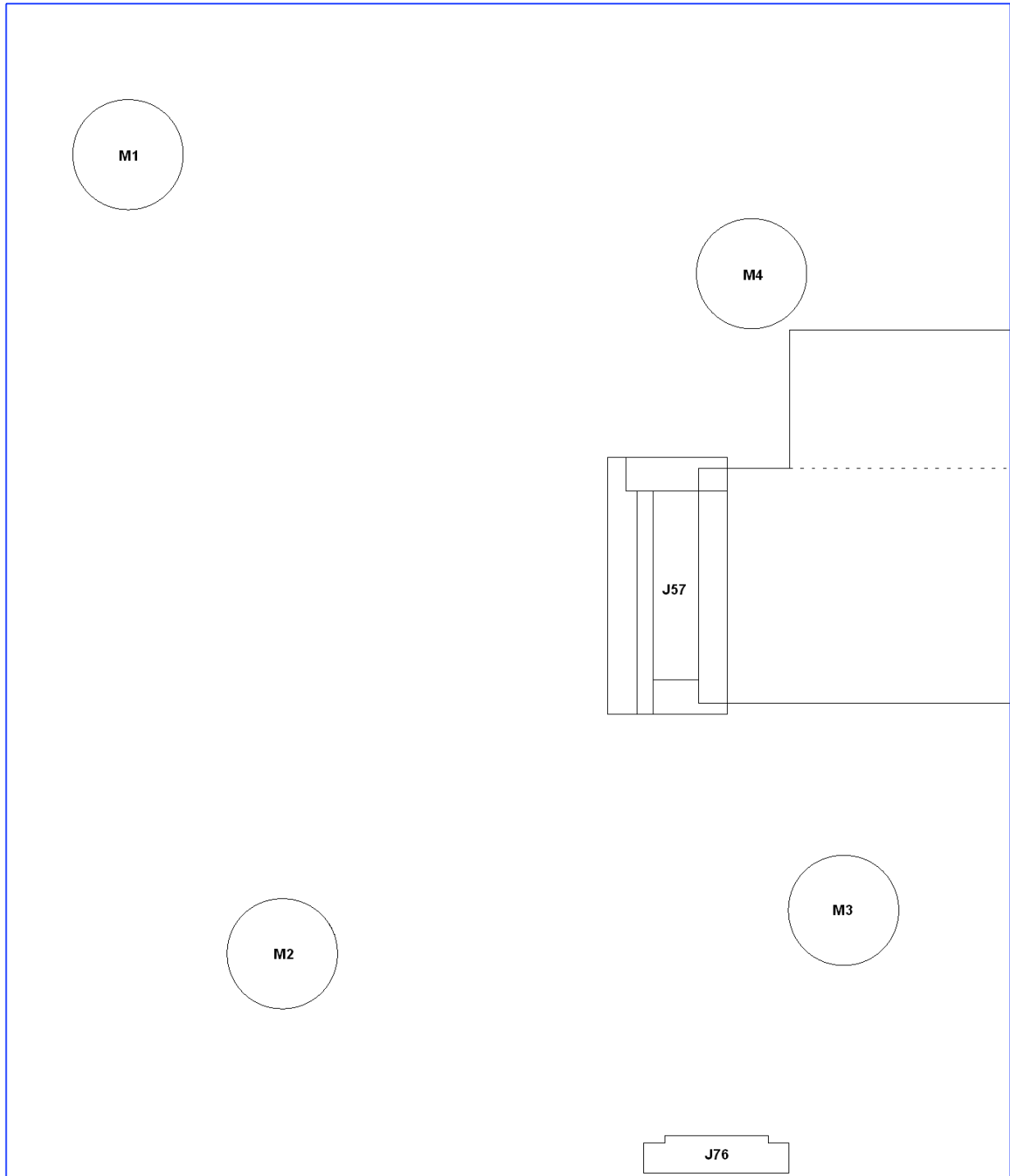

4.2.6 COM Express™ miniBaseboard Type 2 connector overview

Connector	Short Description
BT3	RTC Battery
D139-D142	4 digit LPC/PCI Post Code display
J1	COMexpress Connector
J3	SATA0
J4	Primary IDE
J5	SATA1
J6	LPT
J9	Kontron Feature Connector
J10	PCI Connector
J11	PCIexpress x1
J16	USB Ports 0-3
J17	HDD Activity LED
J26	ATX_PS_ON Override Jumper
J33	SATA2
J34	SATA3
J43	Front Panel Audio Connector
J50	FAN Connector
J51	5.1 Analog HD Audio Connector and optical S/PDIF
J55	JILI40 LVDS
J57	Express Card Slot (on PCB's back side)
J58	ATX Main Power Connector
J59	ATX_12V Power Connector
J61	Front Panel Reset Switch
J62	Front Panel Power Switch
J63	Enable/Disable onboard Speaker
J66	COM1
J67	COM2
J69	Disable Module BIOS for booting from baseboard LPC FWH
J72	electrical S/PDIF out Pin header
J73	USB4/USB6 and RJ45 Ethernet combo connector
J74	USB7
J75	Enable/Disable Winbond 83627 LPC-I/O
J76	CPLD debug connector (bottom side)
J77	VGA and DVI-D combo connector
J79	Enable/Disable Winbond 83627 Keyboard Controller
J80	SPI Flash (optional)
J81	SD-Card Socket
J82	Disable Module BIOS for booting from baseboard SPI Flash
M1 - M4	Rubber feet
SP1	Speaker
SW1	Reset Button
SW2	Power Button

5 Connectors and Features

5.1 Power supply

5.1.1 ATX connector

The miniBaseboard's power supply follows the ATX specification and in default configuration the baseboard should be supplied by connecting an ATX PSU with 20pin ATX and 4pin ATX_12V supply cable in correct orientation. The 4pin ATX_12V connector mainly supplies power to the module over 0R resistor R669. The module is supplied with 5V standby voltage over 0R resistor R670.

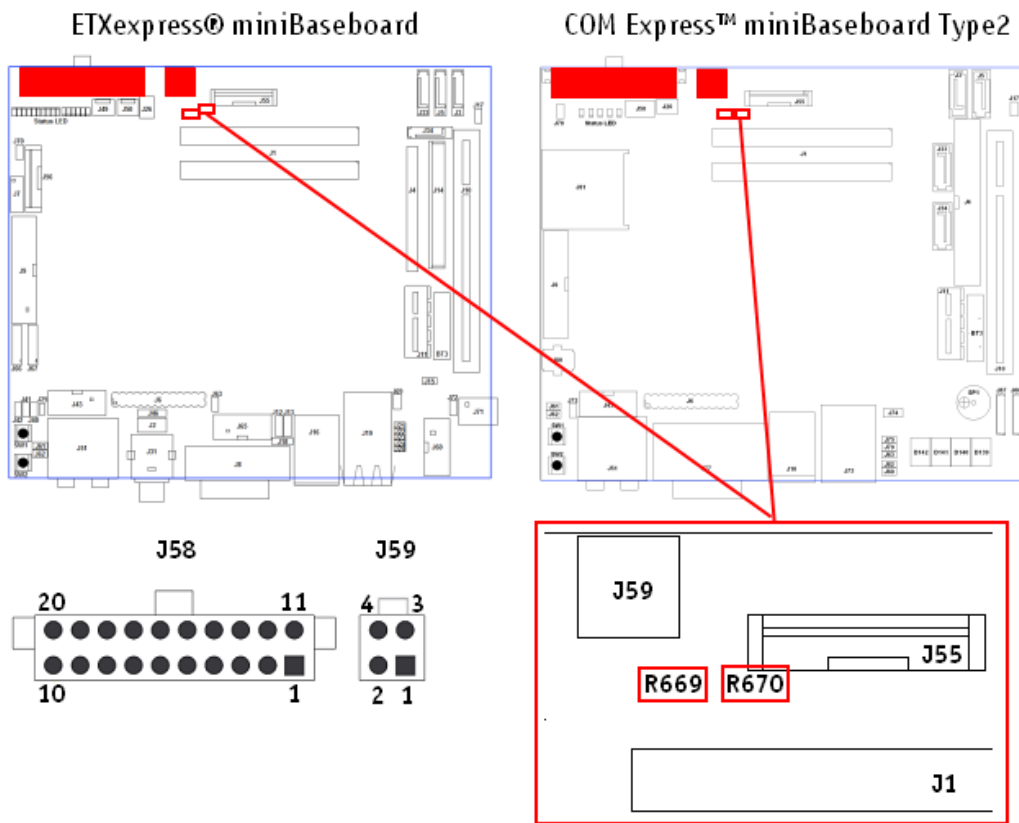

Pin	20pin ATX J58	Pin	20pin ATX J58	Pin	4pin ATX J59
1	+3.3VDC	11	+3.3VDC	1	GND
2	+3.3VDC	12	-12VDC	2	GND
3	GND	13	GND	3	+12VDC or 8.5-18V in single supply mode
4	+5VDC	14	PS_ON	4	+12VDC or 8.5-18V in single supply mode
5	GND	15	GND		
6	+5VDC	16	GND		
7	GND	17	GND		
8	PWR_OK	18	-5VDC		
9	+5VSB	19	+5VDC		
10	+12VDC	20	+5VDC		

5.1.2 PS_ON override

With PS_ON override jumper J26 is possible to switch off the ATX power supply manually.

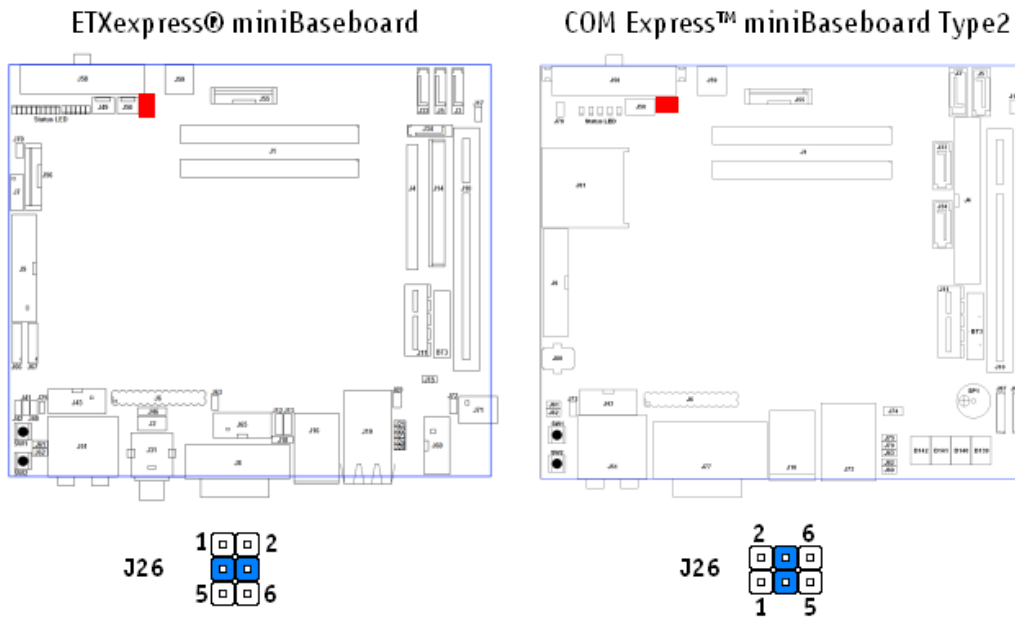

J26 Jumper position	Function
1-2	Power Supply OFF
3-4 (default)	Power Supply controlled by PS_ON signal
5-6	Power Supply always ON

5.1.3 Reset and Power button

The miniBaseboard provides an onboard Reset Button (SW1) and Power Button (SW2). To connect a front panel button from your chassis use J61 (Reset) and J62 (Power).

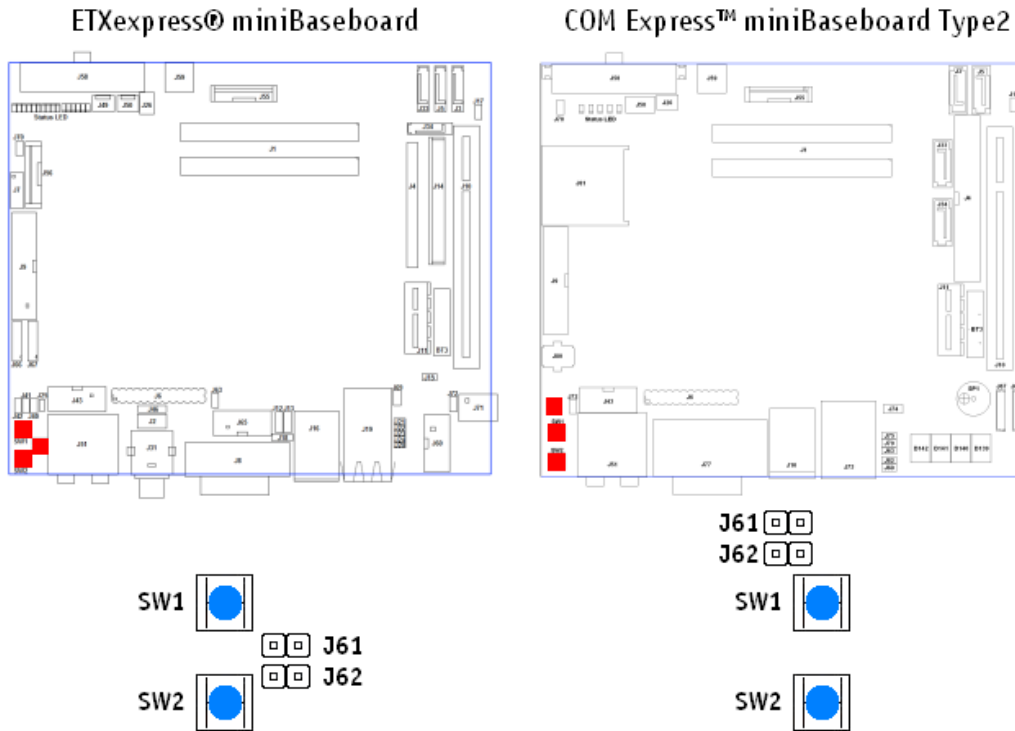

Connector	Function
J61	Reset
SW1	
J62	Power Button
SW2	

5.2 COM Express™ connector

The miniBaseboard is an evaluation backplane for Type2 based modules. Type2 is a module pin-out based on 2 connectors each with 2 rows (Row A and B on connector J1A, Row C and D on connector J1B) with 440 pins overall. Please refer to your module documentation for detailed pin-out descriptions.

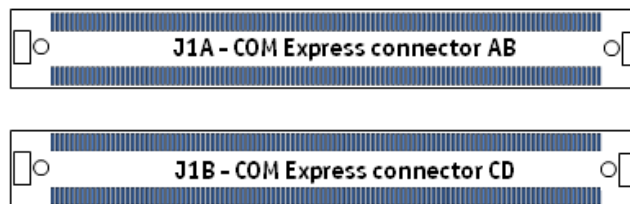
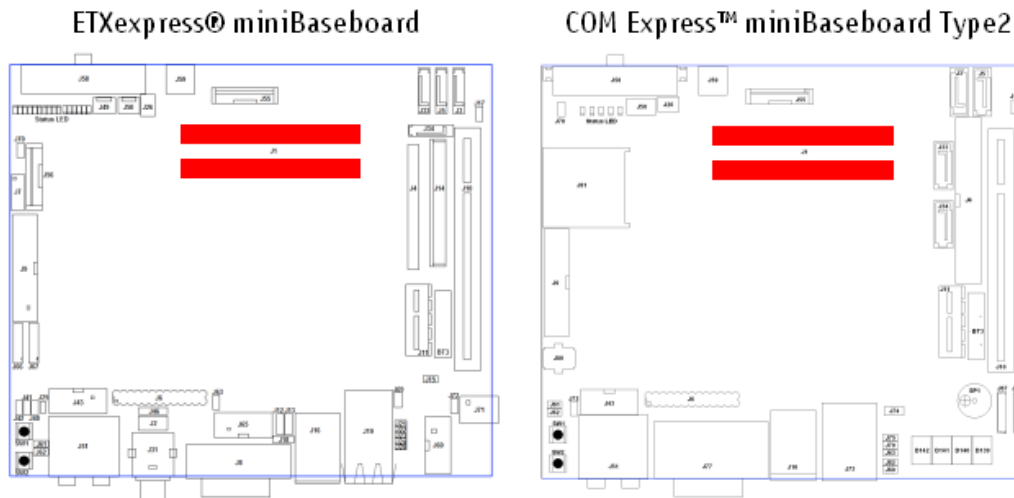

5.3 Status LED

The onboard status and voltage LEDs indicates the current power state of the module and if all voltages are working correctly. Open Jumper J70 on ETXexpress® miniBaseboard to disable the Status LEDs and reduce power consumption in battery driven systems.

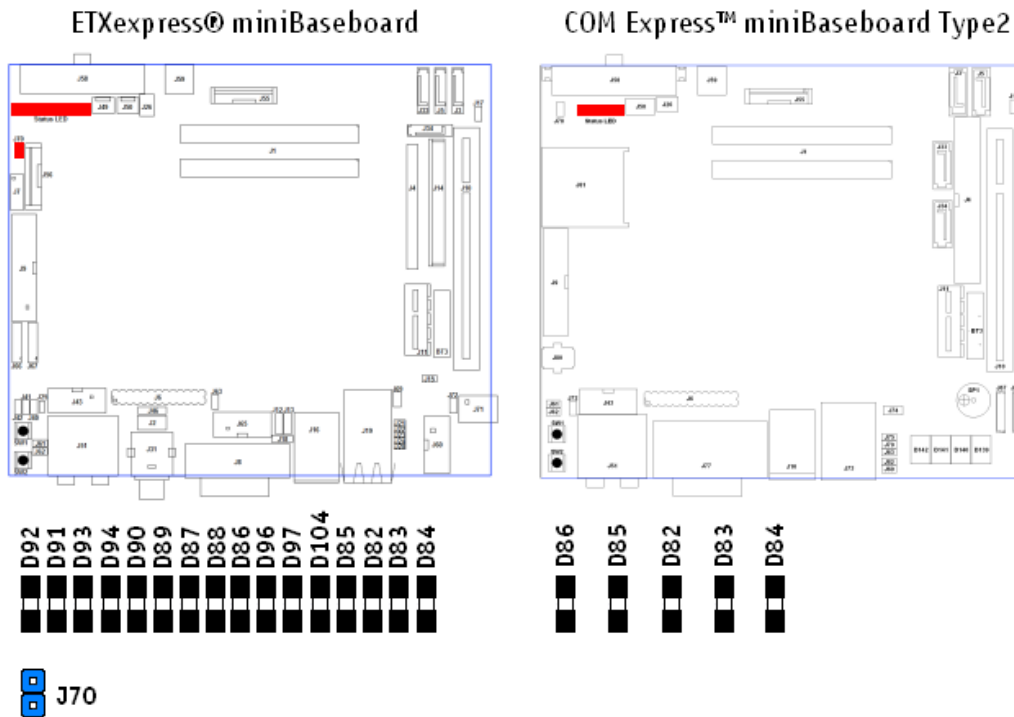

LED	ETXexpress® miniBaseboard	COM Express™ miniBaseboard Type 2
D92	1.5V	-
D91	1.8V	-
D93	2.5V	-
D94	3.3V NoATX mode / CPLD Voltage	-
D90	3.3V Sil	-
D89	3.3V	-
D87	5V Standby	-
D88	5V	-
D86	12V	PWR_OK
D96	12V / Battery (ATX_12V)	-
D97	Type 2 Alarm (indicates if module is not Type 2 compatible)	-
D104	THRM - Temperature Alarm	-
D85	Suspend	Suspend
D82	S3 - Suspend to RAM	S3 - Suspend to RAM
D83	S4 - Suspend to Disk	S4 - Suspend to Disk
D84	S5 - Off State	S5 - Off State

5.4 Serial ATA

The COM Express™ Type 2 pin-out specification defines 4 SATA ports. The miniBaseboard provides four 7-pin SATA data connectors as standard 1.27mm Pitch Serial ATA High Speed Header. On COM Express™ miniBaseboard Type 2 SATA connectors with Locking Latch are used.

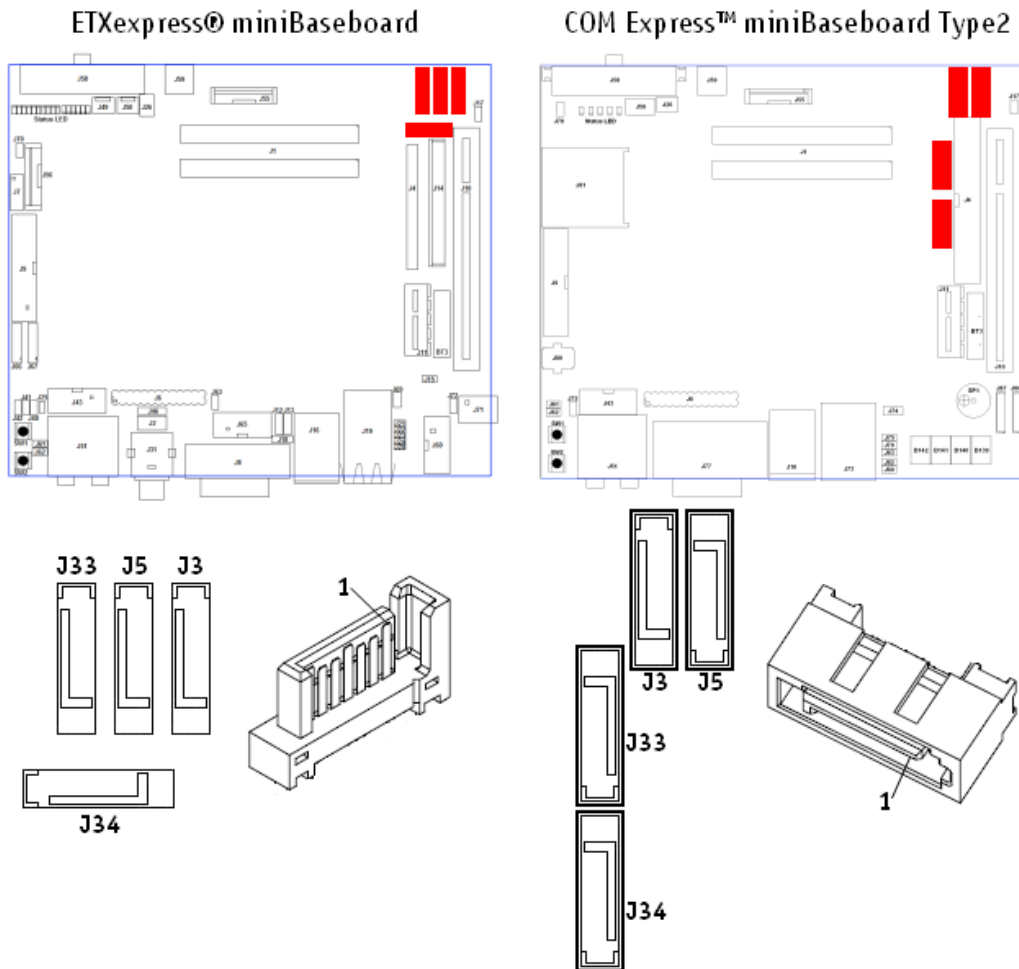

SATA Pin	Signal
1	Ground
2	Transmit +
3	Transmit -
4	Ground
5	Receive -
6	Receive +
7	Ground

Connector	SATA Port
J3	SATA #0
J5	SATA #1
J33	SATA #2
J34	SATA #3

5.5 IDE and Compact Flash

COM Express™ Type2 pin-out defines one PATA channel using up to 2 devices. On ETXexpress® miniBaseboard a Socket for CF-Cards (J14) is usable as IDE Master Device if Master/Slave configuration Jumper J15 is closed. For a second IDE device a 44pin header (J4) is available. On COM Express™ miniBaseboard Type 2 the PATA interface is available on a standard 40pin IDE connector J4.

D69 shows IDE/CF/SATA HDD activity which is also available for a front panel Status LED on connector J17.

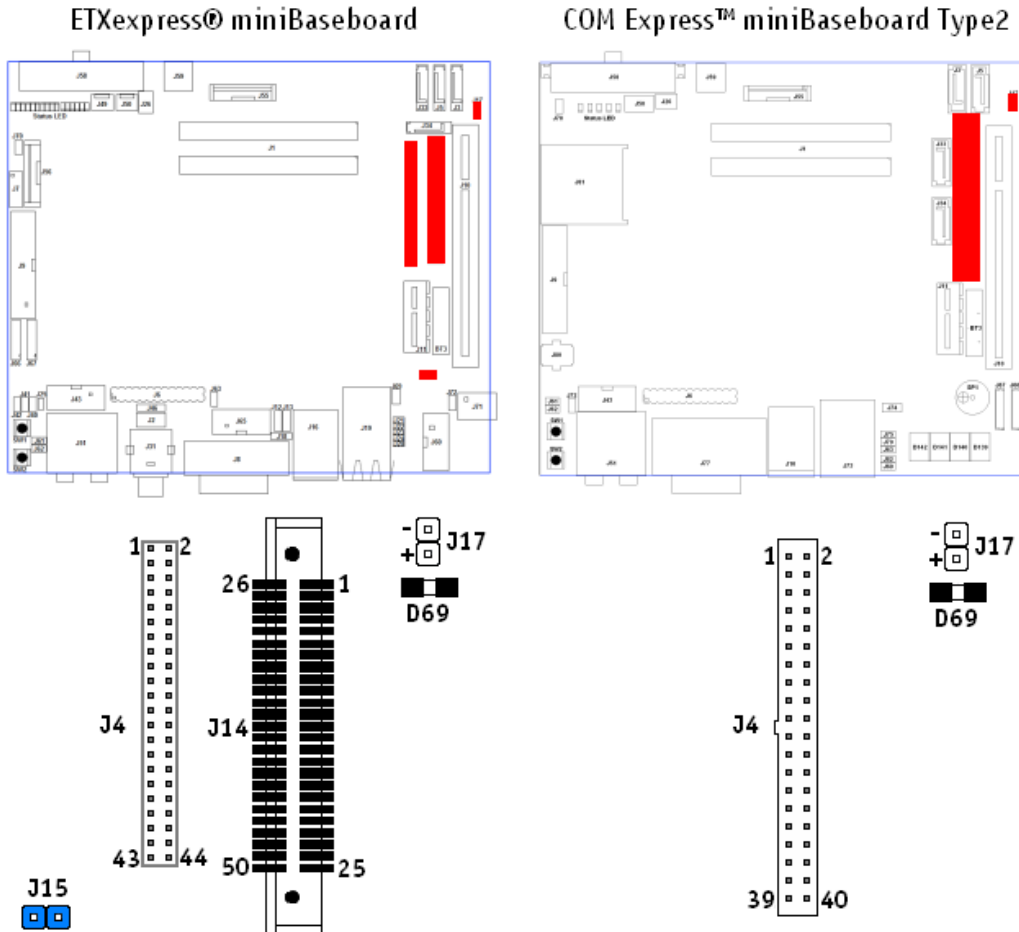

Pin	CF-Card Socket J14	44pin IDE pin header J4	40pin IDE connector J4
1	GND	IDE_Reset#	IDE_Reset#
2	D03	GND	GND
3	D04	D7	D7
4	D05	D8	D8
5	D05	D6	D6
6	D07	D9	D9
7	#CS0	D5	D5
8	GND	D10	D10
9	#ATA_SEL	D4	D4
10	GND	D11	D11
11	GND	D3	D3

12	GND	D12	D12
13	VCC +5V	D2	D2
14	GND	D13	D13
15	GND	D1	D1
16	GND	D14	D14
17	GND	D0	D0
18	A02	D15	D15
19	A01	GND	GND
20	A00	n.c.	n.c.
21	D00	IDE_REQ	IDE_REQ
22	D01	GND	GND
23	D02	#IDE_IOW	#IDE_IOW
24	n.c.	GND	GND
25	n.c.	#IDE_IOR	#IDE_IOR
26	n.c.	GND	GND
27	D11	IDE_IORDY	IDE_IORDY
28	D12	#IDE_CSEL1	#IDE_CSEL1
29	D13	#IDE_ACK	#IDE_ACK
30	D14	GND	GND
31	D15	IDE_IRQ	IDE_IRQ
32	#CS1	n.c.	n.c.
33	GND	IDE_A01	IDE_A01
34	#IOR	#PDIAG	#PDIAG
35	#IOW	IDE_A00	IDE_A00
36	#WE	IDE_A02	IDE_A02
37	INTRQ	#IDE_CS1	#IDE_CS1
38	VCC +5V	#IDE_CS3	#IDE_CS3
39	#CSEL	#DASP / #ATA_ACT (J17)	#DASP / #ATA_ACT (J17)
40	n.c.	GND	GND
41	#RESET	+5V	-
42	IORDY	+5V	-
43	#INPACK	GND	-
44	#REG	n.c.	-
45	#DASP	-	-
46	#PDIAG	-	-
47	D08	-	-
48	D09	-	-
49	D10	-	-
50	GND	-	-

Note: It is strongly recommended to use CF-Cards always as IDE Master Device

5.6 SD-Card

The SD-Card standard is a standard for removable memory storages designed and licensed by the SD Card Association (<http://sdcard.org>). The card form factor, electrical interface and protocol are all part of the SD Card specification. COM Express™ Type 2 pin-out based modules may provide a SDIO interface shared with GPIO signals. Therefore on COM Express™ miniBaseboard Type 2 a SD-Card connector is available. Please check the documentation of your module if SDIO is supported.

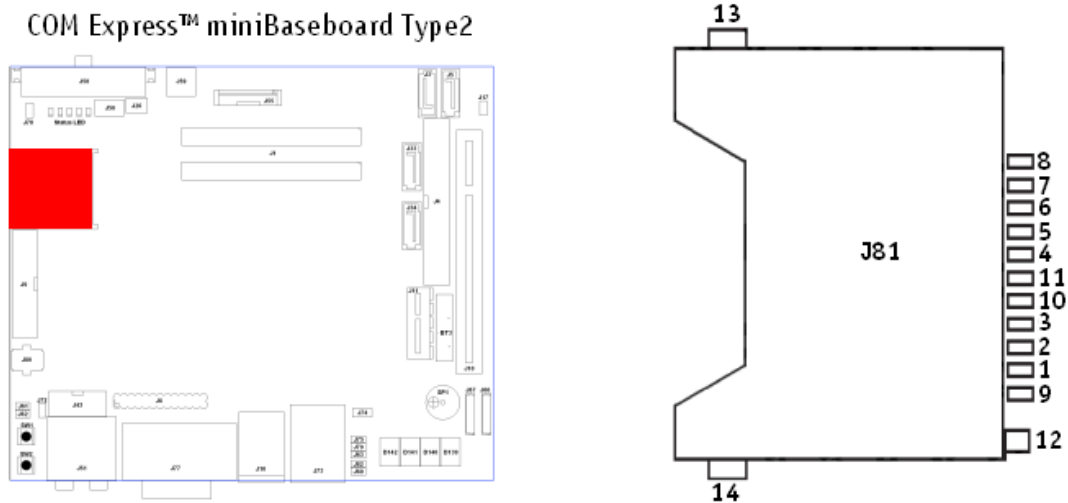

SD-Card J81 PIN	SD-Card connector	COM Express™ Module pin-out
1	DAT3/CD - Data Line 3/Card Detection	GPI3 / SD_DATA3
2	CMD - Command/Response	GP01 / SD_CMD
3	VSS 1 - Supply Voltage - GND	-
4	VDD - Supply Voltage - 3.3V	-
5	CLK - Clock	GP00 / SD_CLK
6	VSS2 - Supply Voltage - GND	-
7	DAT0 - Data Line 0	GPI0 / SD_DATA0
8	DAT1 - Data Line 1	GPI1 / SD_DATA1
9	DAT2 - Data Line 2	GPI2 / SD_DATA2
10	Card Detect	GP03 / SD_CD#
11	Write Protect	GP02 / SD_WP
12	COM	-
13	Shield Ground 0	-
14	Shield Ground 1	-

Note: A SD-Card is detected if Card Detect is at low level. The write protection is active (read only) if SD_WP is at high level.

5.7 High Definition Audio

5.7.1 Front Panel and internal connectors

On both miniBaseboards a Realtek ALC888 High Definition Audio Codec supports analog, optical and digital audio connection.

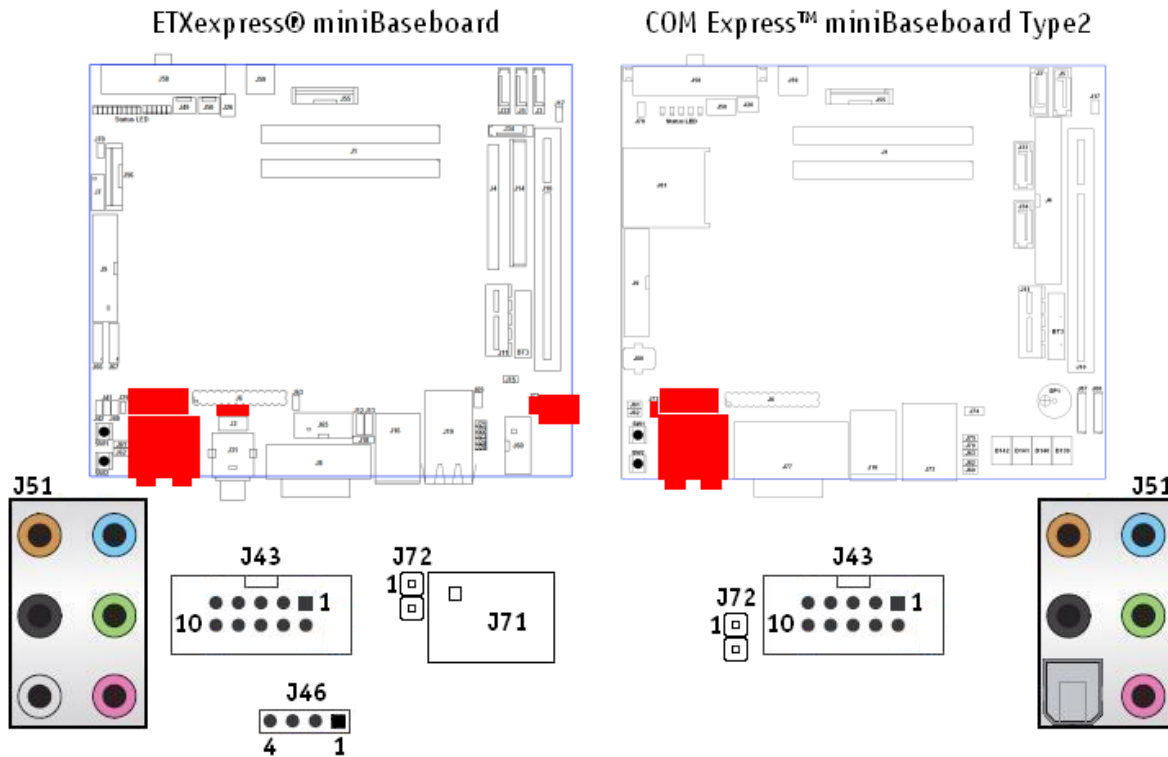

Audio Connector J51 - Speaker Configuration

The Audio Connector J51 on ETXexpress® miniBaseboard is a full featured analog audio jack for speaker configuration up to 8-channel. On COM Express™ miniBaseboard Type 2 the Audio Connector combines analog audio output with an optical Toslink S/PDIF replacing J71. Therefore only 6-channel speaker configuration is possible.

J51	2-channel	4-channel	6-channel	8-channel
Orange	-	-	Center/Subwoofer	Center/Subwoofer
Black	-	Rear Speaker	Side Speaker	Rear Speaker Out
Gray	-	-	-	Side Speaker Out
Blue	Line In	Line In	Line In	Line In
Green	Line Out	Front Speaker	Front Speaker	Front Speaker
Pink	Mic In	Mic In	Mic In	Mic In

Front Panel Audio Connector J43

The front panel audio connector J43 allows connecting a chassis front panel audio with analog microphone input and stereo speaker output.

Pin	J43 HD
1	MIC2-L
2	GND
3	MIC2-R (MIC Power)
4	PRESENCE#
5	LINE2-R (LineOut-R)
6	MIC2-JD
7	SENSE
8	Key Pin
9	Line2-L (LineOut-L)
10	LINE2-JD

Digital Audio Connectors J46/J72

J46 - only available on ETExpress® miniBaseboard provides a digital microphone input. On both baseboard revisions J72 can be used for digital S/PDIF output.

J46	J72
DMIC-CLK	SPDIF_OUT
DMIC-DATA	GND
PWR_3.3V	-
GND	-

Note1: In addition to the default speaker settings, the analog audio Jacks can be reconfigured to perform different functions via the Realtek HDAudio Driver Software which is available on Kontron website. Only microphones still must be connected to the default pink jack.

Note2: Audio is only supported with HD Audio compatible COM Express Modules.

5.7.2 Onboard Speaker

The miniBaseboard supports an onboard Piezo Speaker connected to HD Audio Codec's PCBeep output. Remove Jumper J63 to disable the speaker.

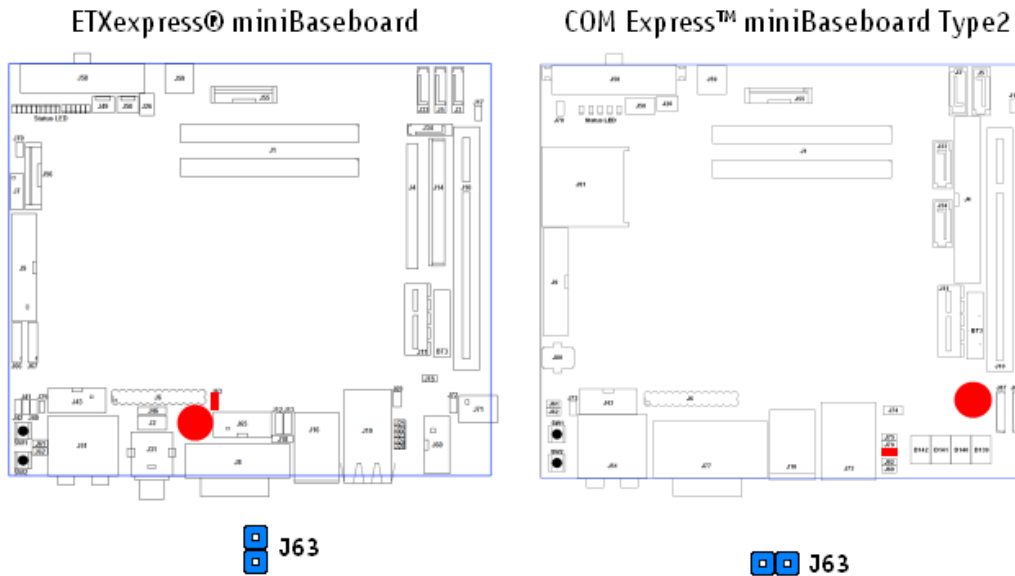

5.8 Ethernet

The 10/100/1000 Base-T RJ45 single port Ethernet jack with integrated LEDs and magnetics on ETXexpress® miniBaseboard is compatible to modules with Gigabit or with 10/100 Fast Ethernet Controller. By default the configuration jumpers J20-J24 are closed for modules with Gigabit Ethernet. Open all Jumpers when using a module with 10/100 Fast Ethernet controller.

The COM Express™ miniBaseboard Type 2 provides a RJ45/Dual USB Combo with a single RJ45 in combination with 2 USB ports (USB 4/6). Ethernet Connector J73 with integrated magnetics and LEDs is configured to support modules with Gigabit Ethernet controller only. Modules with 10/100 MBit Ethernet controller are not supported.

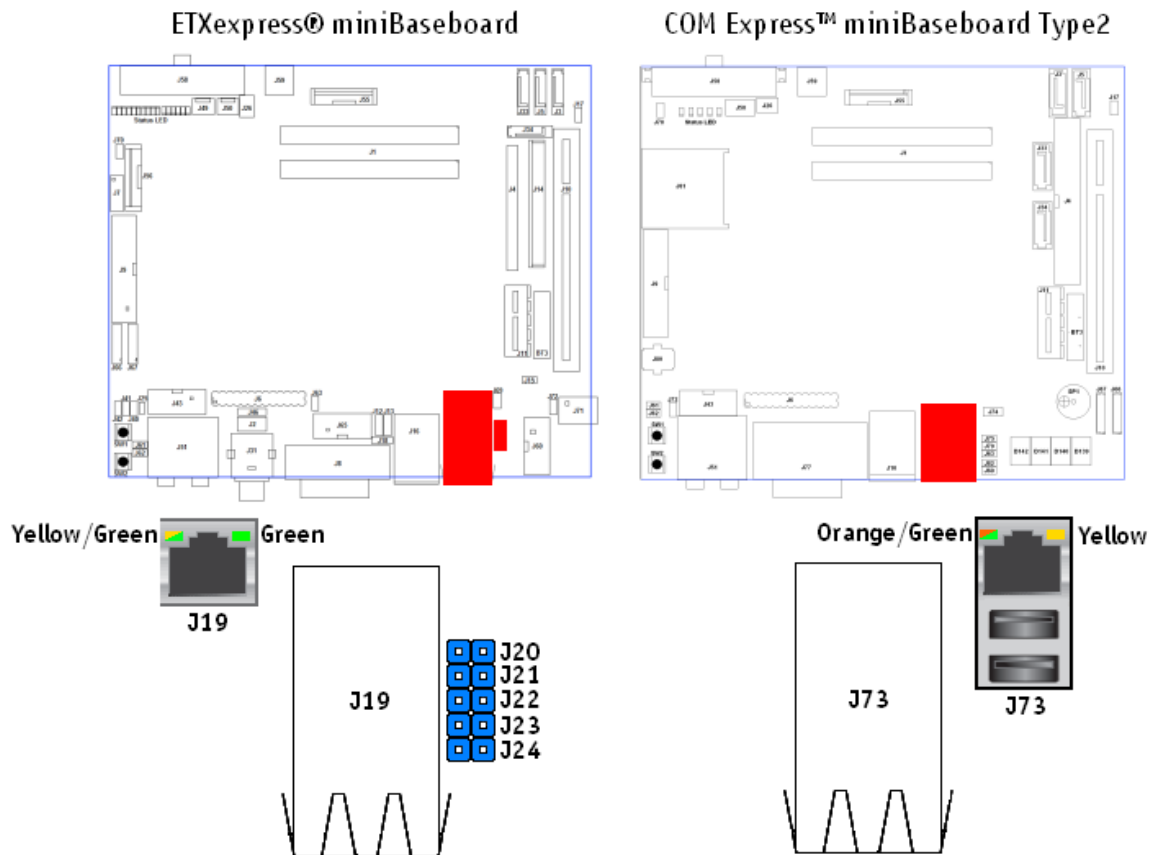

LED function

Left LED	Right LED	J19 Function
Green		Link1000
Yellow		Link100
Off		Link10
	Green	Activity

Left LED	Right LED	J73 Function
Orange		Link1000
Green		Link100
Off		Link10
	Yellow	Activity

5.9 USB

On both baseboards the COM Express™ module's USB ports 0 to 3 are available on rear panel connector J16 and USB port 5 is used on Express Card connector. The ETXexpress® miniBaseboard provides USB port 4 and 6 on connector J65 for a standard USB front panel connector.

On COM Express™ miniBaseboard Type 2 these USB ports are available directly on RJ45/USB Combo connector J73. Additionally USB7 is available via pin header J74 as non-powered USB connector for USB client functionality. Check the documentation of your module if USB client on Port #7 is supported and J74 can be used.

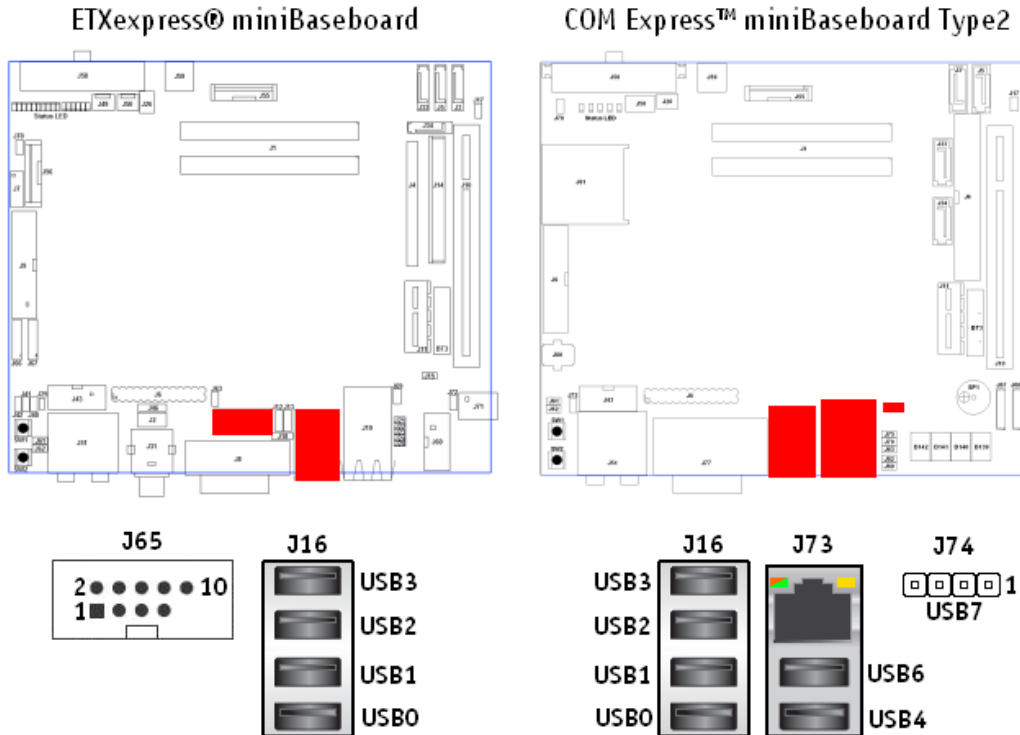

J65 Pin	Function
1	VCC USB4
3	USB4-
5	USB4+
7	GND USB4
9	Key pin
2	VCC USB6
4	USB6-
6	USB6+
8	GND USB6
10	n.c.

J74 Pin	Function
1	GND
2	USB7+
3	USB7-
4	n.c. Optional: +5V

Note: USB7 connector J74 is configured to a USB client connector by default. To use it as standard USB output +5V VCC on pin 4 can be enabled optionally. Solder FB98 (Ferrit Chip Bead, 600 Ohm, 1A, 100MHz; bottom) if necessary. See assembly instructions for position of FB98.

5.10 PCI

Both miniBaseboards provide one PCI Slot following the PCI 2.x specification.

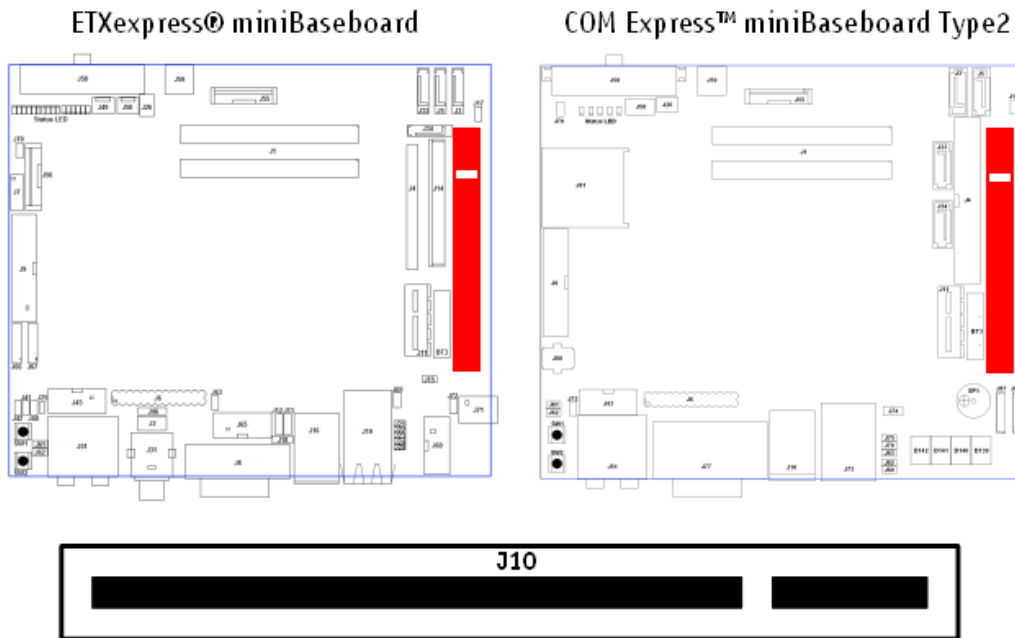

5.11 PCIeexpress and Express Card

The miniBaseboard provides one PCIeexpress x1 port and one Express Card Slot in following configuration:

	ETXexpress® miniBaseboard	COM Express™ miniBaseboard Type 2
J11 (PCIe x1)	COM PCI express Lane #3	COM PCI express Lane #0
J57 (Express Card)	COM PCI express Lane #0 / USB #5	COM PCI express Lane #1 / USB #5

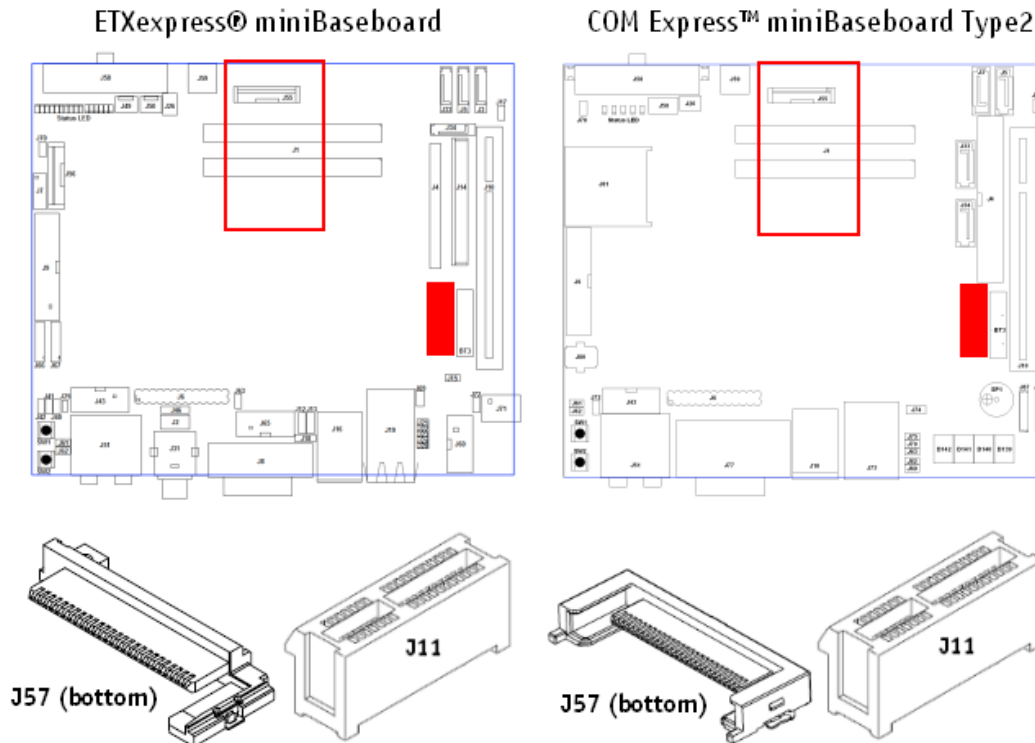

The Express Card Slot J57 allows 1.3A on 3.3V, 275mA on AuxPower and 650mA on 1.5V continuous Card Power with following pin-out:

Pin	J57 Signal	Pin	J57 Signal
1	GND	14	3.3VS_1
2	USB_D-	15	3.3VS_0
3	USB_D+	16	CLKREQ#
4	CPUSB#	17	CPPE#
5	NC	18	REFCLK-
6	NC	19	REFCLK+
7	SMB_CLK	20	GND
8	SMB_DATA	21	PERNO
9	1.5V_2	22	PERPO
10	1.5V_1	23	GND_1

5.12 Kontron Feature connector

The Kontron Feature connector provides additional interfaces such as I2C, SMBus or Power Control Signals. See the table below for detailed pin-out description

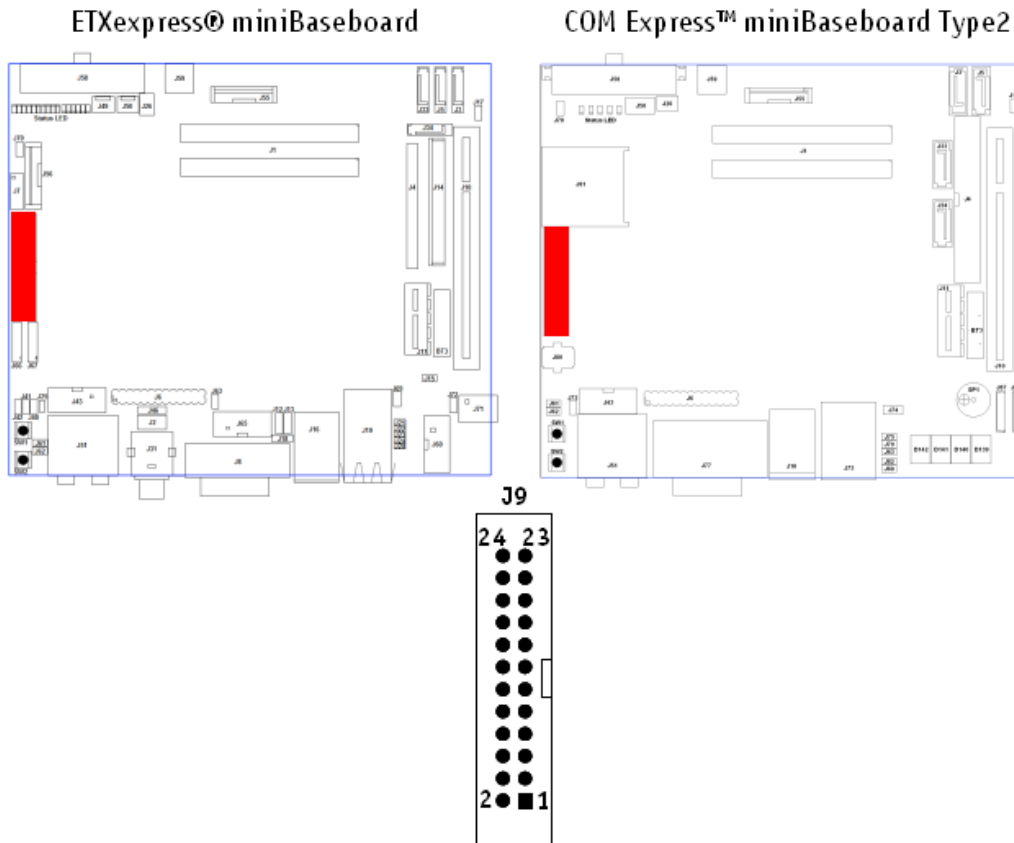

Pin	Signal	Level	Signal Description
1	PWR_+5V	5V power	+5V UL-protected with inductor (600R@100MHz, 1A)
2	GP02	3.3V-0	General-purpose power management event output
3	#BATLOW	3.3V-I	Battery low input. May be driven low by external circuitry to signal that the system battery is low, or may be used to signal some other external power management event.
4	GPI2	3.3V-I	General-purpose power management event input
5	#SYS_RESET	3.3V-I	This input may be driven low by external circuitry in order to reset the power management logic
6	WDT	3.3V-0	Indicating that a Watchdog Timeout Event has occurred
7	LPC_SERIRQ	3.3V-I	Serial interrupt request. This pin is used to support the serial interrupt protocol.
8	-	-	Not connected
9	I2C_DAT	3.3V-I/O	Data line of I2C-Bus
10	#SMB_ALERT	3.3V-I	System Management Bus Alert input. May be driven low by SMB devices in order to signal an event on the SM Bus
11	I2C_CLK	3.3V-0	Clock line of I2C-Bus
12	SMB_DAT	3.3V-I/O	Clock and data line of SM-Bus.
13	SMB_CLK	3.3V-0	
14	-	-	Not connected
15	#WAKE1	3.3V-I	Low driven general purpose wake-up signal

16	VCC_RTC	3V-I	3V backup cell input. Should be connected to a 3V backup cell for RTC operation and storage register non-volatility in the absence of system power. (VBATT = 2.4 – 3.3V)
17	#THRM	3.3V-I	Input from off-module temperature sensor indicating an over temperature situation
18	GND	GND	Ground
19	PWR_OK	3.3V-I	High active input indicating that power from the power supply is ready. It can also be used as low active reset input signal.
20	GND	GND	Ground
21	#PWRBTN	3.3V-I	Power Button Input. This input is used to support the ACPI Power Button function.
22	GND	GND	Ground
23	#ATA_ACT	3.3V-O	Low active output signal, which indicates activity on IDE interfaces.
24	#CB_RESET	3.3V-O	Low active Reset output from module to carrier board

5.13 DVI and VGA

To connect a standard VGA monitor directly to the module's VGA output use connector J77A on COM Express® miniBaseboard Type 2 or use a DVItoVGA Adapter to access the available VGA connection on DVI-I connector J8 on ETXexpress® miniBaseboard. The DVI output is available through a Silicon Image SiL1364/A SDVO_B to single link DVI PanelLink Transmitter

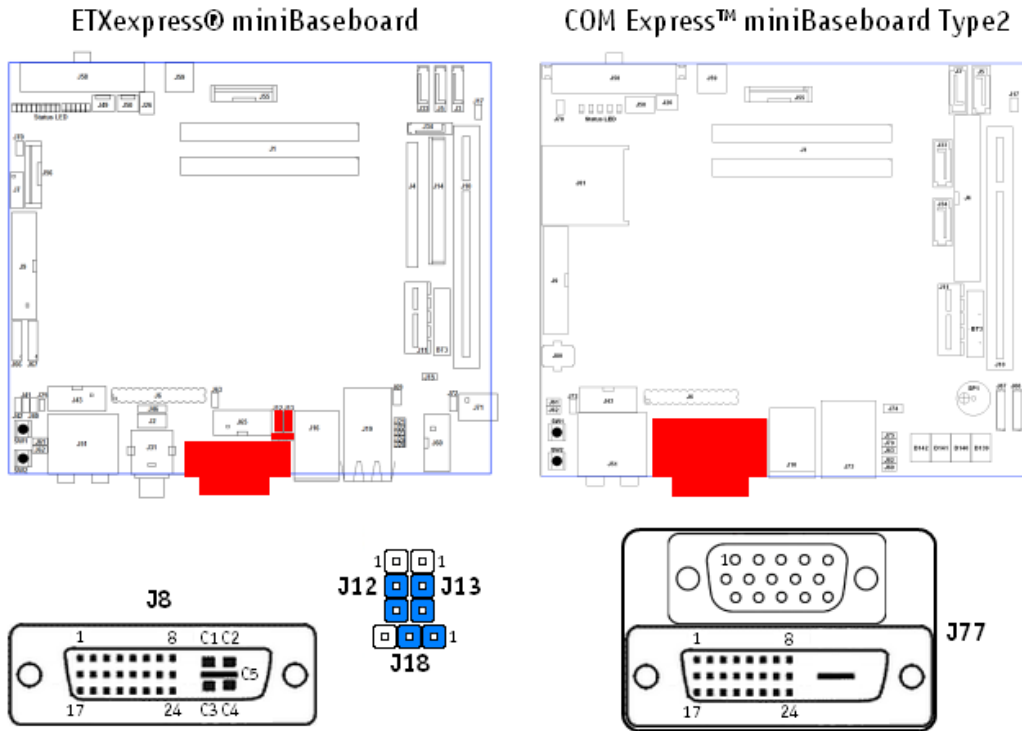

The default jumper configuration for J12 and J13 on ETXexpress® miniBaseboard enables DVI DDC Data usage with 5V bus level voltage. To enable VGA I2C connection short pin 1 and 2 of J12 and J13. To change voltage level on DDC I2C bus to 3.3V short pin 2 and 3 of jumper J18:

Pin	J12	J13	J18
1	VGA I2C Data	VGA I2C Clock	PWR_+5V
2	DDC Data	DDC Clock	DDC Clock Pull Up
3	DVI DDC Data	DVI DDC Clock	PWR_+3.3V

Note1: The default display configuration in the BIOS Display settings for most Kontron ETXexpress modules is set to "CRT and LVDS". To use a DVI monitor directly the BIOS Display settings may be changed to "SDVO only" or "CRT and SDVO". Newer BIOS revisions enable SDVO output automatically if no LVDS device is present.

Note2: It's strongly recommended to use a VGA monitor or LVDS display during Windows OS installation. Windows may disable the SDVO output during installation.

Note3: The Intel® GMA driver may disable the SDVO output on platforms with Intel® chipsets. Press the default GMA driver hotkey "CTRL+ALT+F4" when the reboot after driver installation has finished to enable Digital Display.

5.14 LVDS

The 40-pin JILI LVDS panel connector J55 allows connecting a flat panel directly to the module's dual channel LVDS output. The ETXexpress® miniBaseboard additionally provides a second LVDS connection J56 converted from module's SDVO-C channel with a Chronitel CH7308B SDVO to LVDS transmitter.

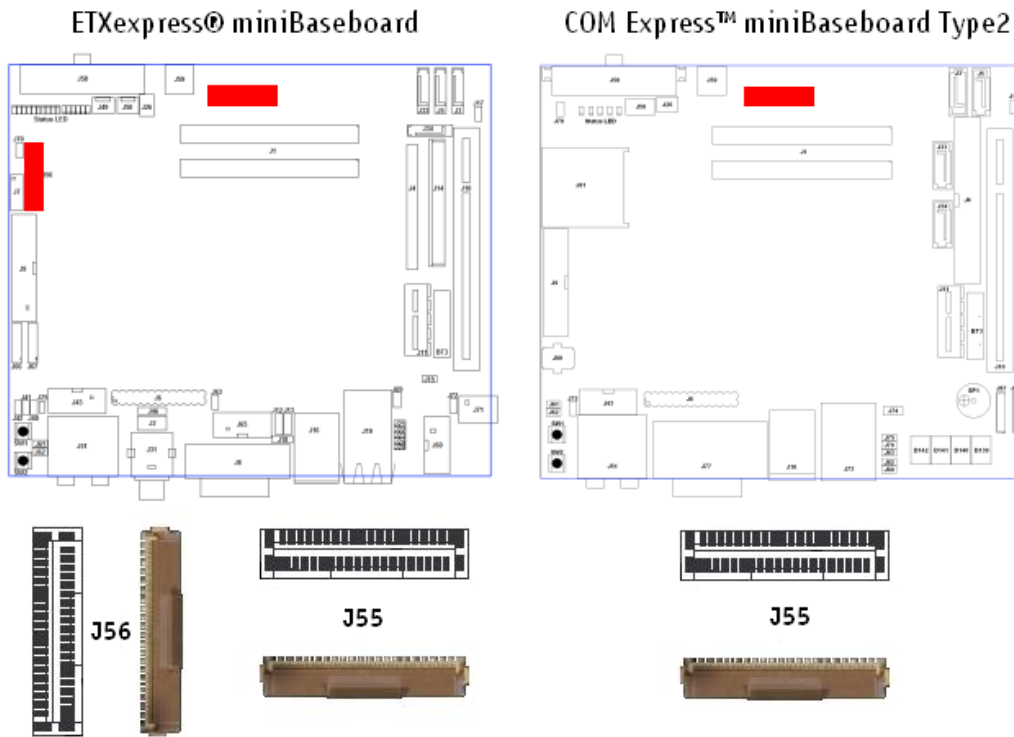

J55/J56 Pin	LVDS Signal	J55/J56 Pin	LVDS Signal
1	NC	21	LCDD013
2	LCDD00	22	DETECT# (GND)
3	LCDD01	23	LCDD014
4	ENAVDD	24	LCDD015
5	LCDD02	25	GND
6	LCDD03	26	LCDD016
7	NC	27	LCDD017
8	LCDD04	28	GND
9	LCDD05	29	LCDD018
10	GND	30	LCDD019
11	LCDD06	31	+5V
12	LCDD07	32	+5V
13	GND	33	+5V
14	LCDD08	34	+5V
15	LCDD09	35	BLON#
16	JILI_DAT	36	GND
17	LCDD010	37	GND
18	LCDD011	38	+12V
19	JILI_CLK	39	+12V
20	LCDD012	40	+12V

5.15 TV-Out

The ETXexpress® miniBaseboard follows PICMG COM.0 specification Rev 1.0 which defines an optional TV-out. Therefore the baseboard provides three possible TV-Out connections. Composite Video (Yellow Cinch) and S-Video out is available on the rear panel connector J31. Component TV-Out is available via pin header J2. See the tables below for configuration details. For more details about TV-Out connection refer to your module documentation.

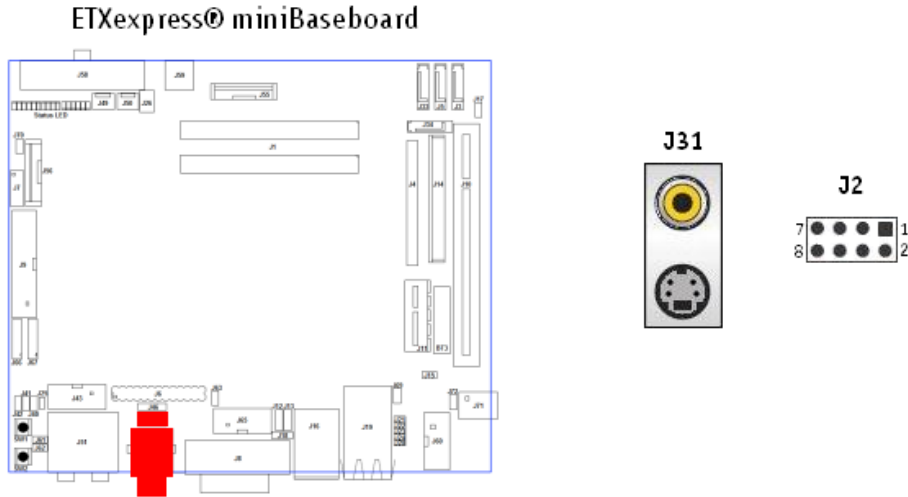

J2 pin-out

Pin	J2 Function	Pin	J2 Function
1	TV_DAC_A	2	GNDA
3	TV_DAC_B	4	GNDB
5	TV_DAC_C	6	GNDC
7	GNDA	8	NC

J2 TV-Out configuration

Pin	Composite Video	S-Video	Component Video
TV_DAC_A	CVBS (composite)	-	Pb (Chrominance)
TV_DAC_B	-	Y (Luminance)	Luminance
TV_DAC_C	-	C (Chrominance)	Pr (Chrominance)

5.16 External BIOS

Both miniBaseboards support external boot. By closing Jumper J69 on both baseboards the module's onboard BIOS is disabled and the system will boot from an external Firmware Hub in U43 PLCC socket on baseboard's bottom side.

For modules supporting SPI boot the COM Express™ miniBaseboard Type 2 provides a SPI socket J80 for an optional available SPI Flash. SPI is part of COM.0 Specification Rev 2.0 and external SPI boot can be enabled by closing Jumper J82. Please check the documentation of your module if SPI is supported and which SPI Flash is required.

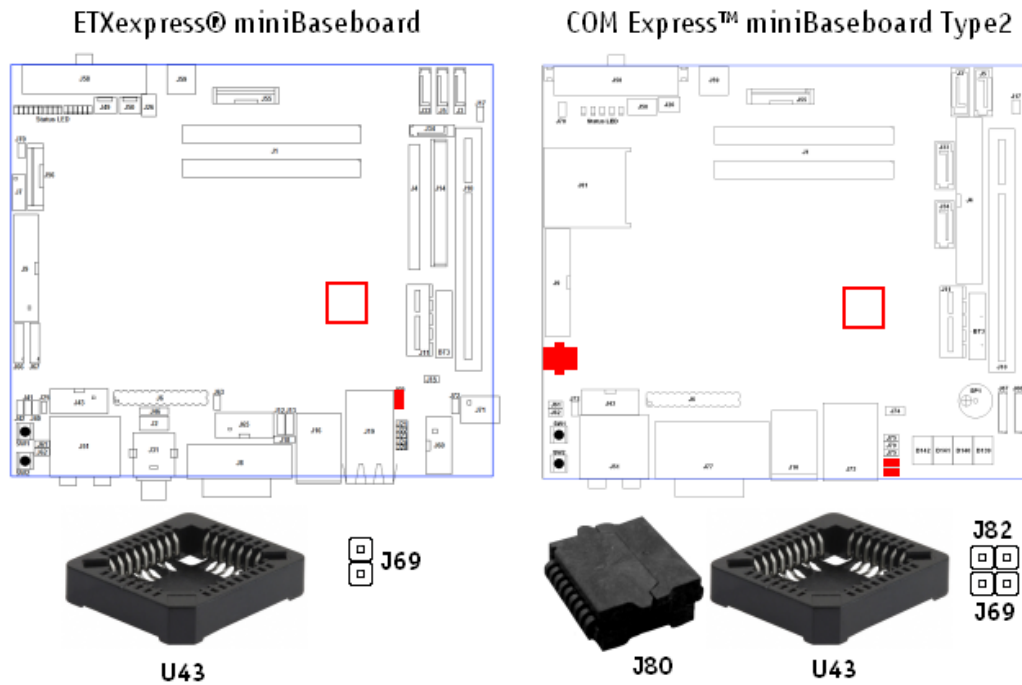

5.17 CPLD & POST-Code Display

For Power Management control both miniBaseboards are equipped with an Altera CPLD (U105) on baseboard's bottom side. On COM Express™ miniBaseboard Type 2 the CPLD controls the 4 digit LPC/PCI Post Code Display D139 to D142.

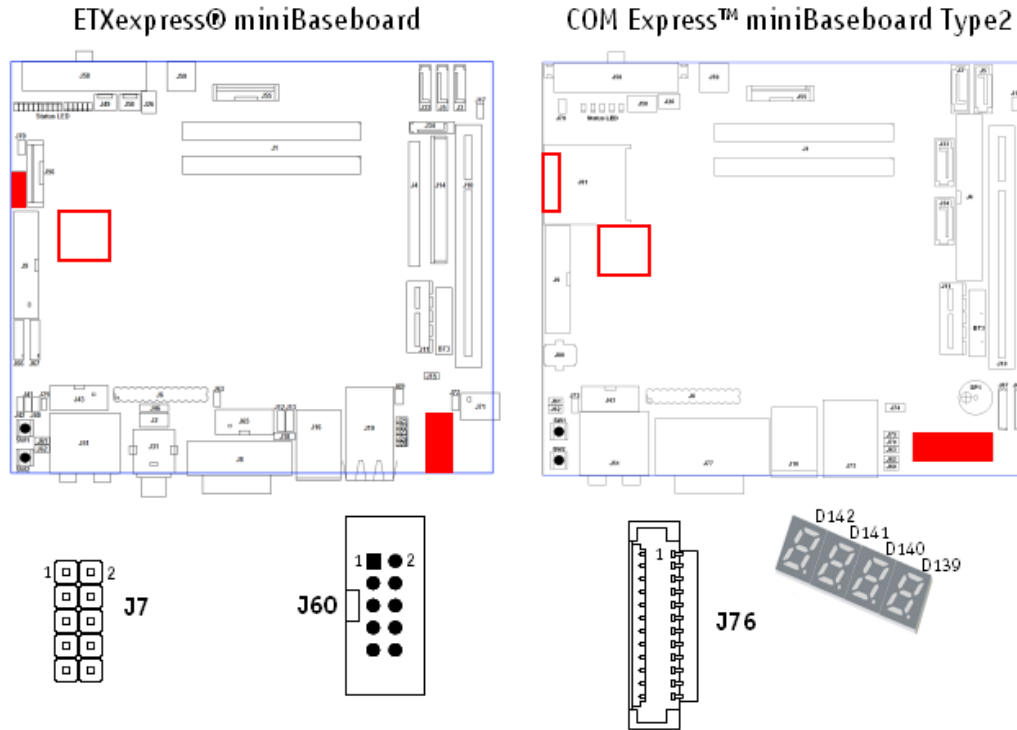

J7 - CPLD I/O Port

The I/O Port J7 provides 10 I/O ports directly from the CPLD and is without any function in default configuration. The I/O port is only available on ETXexpress® miniBaseboard.

J7 pin	Function	J7 pin	Function
1	CPLD_IO1	2	CPLD_IO2
3	CPLD_IO3	4	CPLD_IO4
5	CPLD_IO5	6	CPLD_IO6
7	CPLD_IO7	8	CPLD_IO8
9	CPLD_IO9	10	CPLD_IO10

J60 - CPLD JTAG Connector

For CPLD programming the CPLD JTAG connector J60 is only available on ETXexpress® miniBaseboard

J7 pin	Function	J7 pin	Function
1	TCK	2	GND
3	TDO	4	+3.3V_noATX
5	TMS	6	n.c.
7	n.c.	8	n.c.
9	TDI	10	GND

J76 - CPLD Debug connector

On COM Express™ miniBaseboard Type 2 a full featured 12pin debug connector J76 is available for CPLD programming and debugging.

J7 pin	Function	J7 pin	Function
1	+3.3V_S5	7	MCCI_DATA_IN
2	TDI	8	MCCI_RESET
3	TCK	9	MCCI_CLK
4	TMS	10	CPLD_GP1
5	TDO	11	CPLD_GP2
6	MCCI_DATA_OUT	12	GND

5.18 Winbond 83627 Super-I/O

A Winbond 83627HG Super-I/O controller is connected module's LPC bus on ETXexpress® miniBaseboard. The COM Express™ miniBaseboard Type 2 includes a Winbond 83627HFJ Super-I/O. Both LPC-I/O controller offers legacy interfaces like RS232 and parallel ports additionally to temperature, FAN and voltage monitoring features.

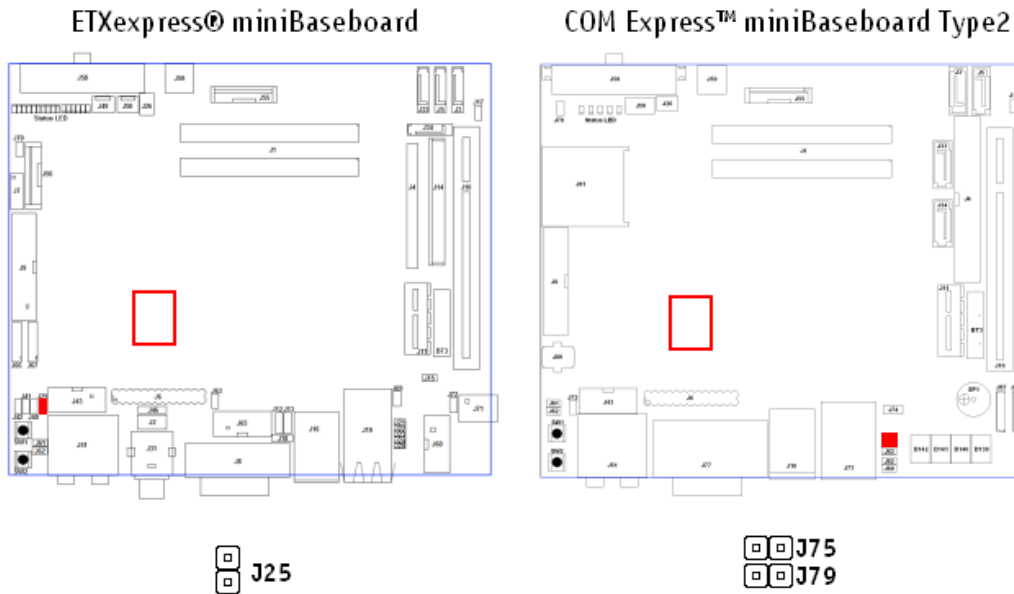

Modules with onboard Super-I/O may conflict with the standard LPC-I/O address 2Eh. Therefore it's possible on ETXexpress® miniBaseboard to change the LPC address to 4Eh by closing jumper J25.

On COM Express™ miniBaseboard Type 2 the configuration jumpers J75 and J79 allow disabling the KBC or holding the Super-I/O in reset to simulate a legacy free backplane.

Configuration Settings for LPC-I/O:

Jumper		ETXexpress® miniBaseboard	COM Express™ miniBaseboard Type 2
J25	open (default)	SIO LPC address 2Eh	-
	closed	SIO LPC address 4Eh	-
J75	open	-	SIO disabled (hold in Reset)
	closed (default)	-	SIO enabled
J79	open (default)	-	Keyboard Controller disabled
	closed	-	Keyboard Controller enabled

5.18.1 RS232

With Winbond 83627 LPC-I/O two serial ports are supported. See pin-out of COM1 (J66) and COM2 (J67) in table below. Use the optional available [KAB-DSUB9-3](#) cable adapter to access the serial ports. Check to module BIOS to configure the serial port resources.

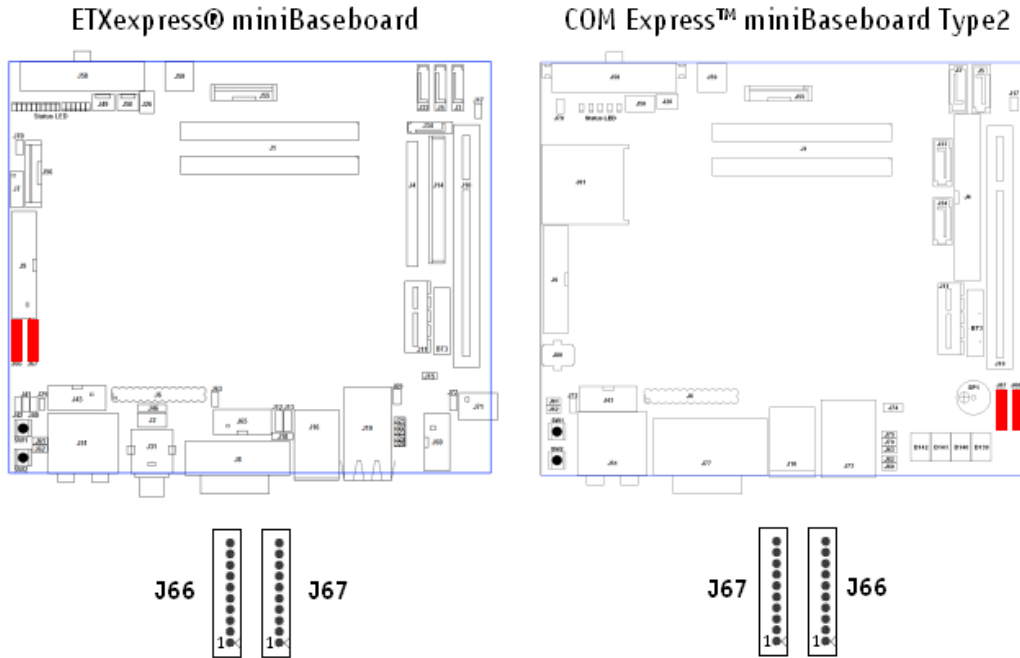

J66/J67 Pin	Signal	J66/J67 Pin	Signal
1	DCD	6	CTS
2	DSR	7	DTR
3	RXD	8	RI
4	RTS	9	GND
5	TXD	10	n.c. on ETXexpress® miniBaseboard +5V on COM Express™ miniBaseboard Type2

5.18.2 LPT

The Winbond 83627 LPC-I/O supports one parallel port available on baseboard's pin header J6. Use the optional available [KAB-DSUB25-1](#) cable adapter to access the LPT port and check to module BIOS to configure the port resources.

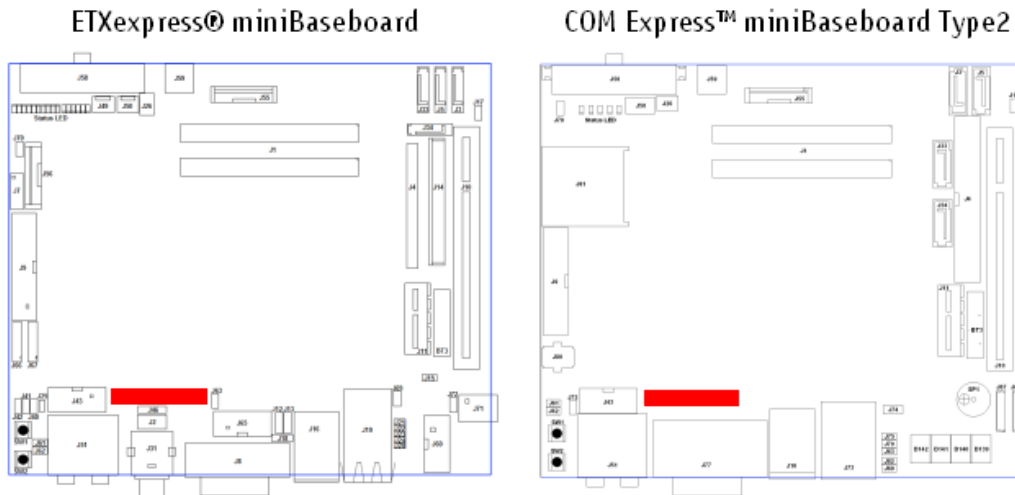

J6

Pin	Signal	Pin	Signal
1	#STB	2	#AFD
3	PD0	4	#ERROR
5	PD1	6	#INIT
7	PD2	8	#SLCTIN
9	PD3	10	GND
11	PD4	12	GND
13	PD5	14	GND
15	PD6	16	GND
17	PD7	18	GND
19	#ACK	20	GND
21	BUSY	22	GND
23	PE	24	GND
25	SLCT	26	PWR_+5V

5.18.3 FAN

On ETXexpress® miniBaseboard two 3-pin Fan connectors for FAN1 (J49) and FAN2 (J50) are available for system cooling controlled by the LPC-I/O.

The COM Express™ miniBaseboard Type 2 provides one 4-pin PWM FAN connector directly controlled by the LPC-I/O PWM output 1.

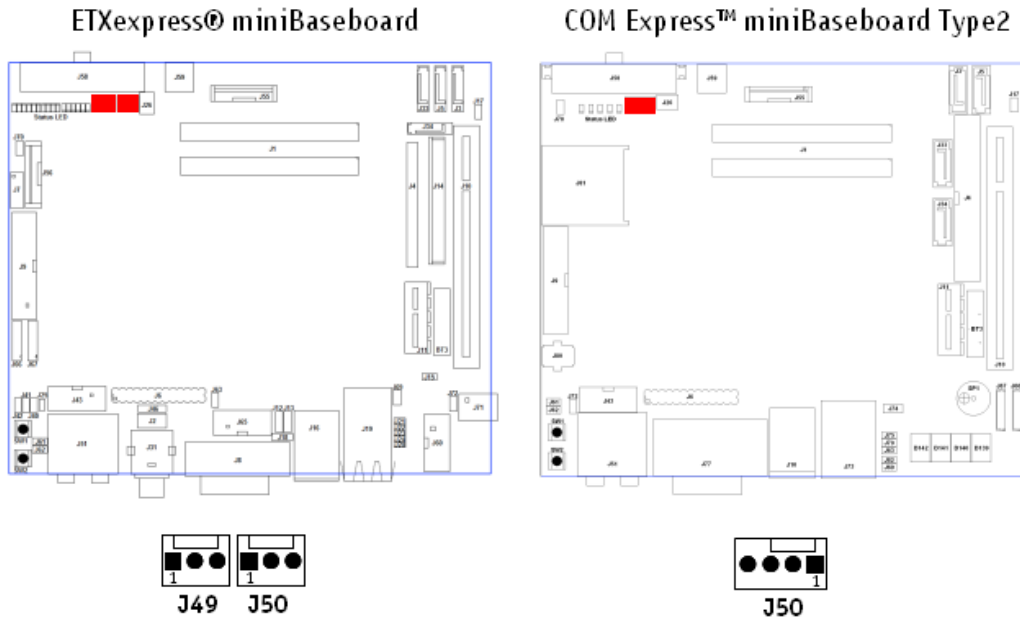

Fan pin-out

Pin	J49 / J50 on ETXexpress® miniBaseboard	J50 on COM Express™ miniBaseboard Type 2
1	Sense	GND
2	+12V (default) 8.5V - 12V in Single Supply mode Optional: +5V in ATX and Single Supply mode	+12V (default) Not supported in Single Supply mode Optional: +5V in ATX and Single Supply mode
3	GND	Sense
4	-	Control (PWM)

Note: In default ATX mode all Fan connectors are configured to 12V. Optionally all connectors can be modified to 5V output in ATX and Single Supply mode. See single supply assembly instructions how to fix fan voltage outputs to 5V.

5.18.4 Temp Sensor

The ETXexpress® miniBaseboard provides 3 thermal diode inputs from Winbond's Temp1-3 input (VTIN1-3) for external temperature measurements.

ETXexpress® miniBaseboard

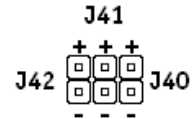
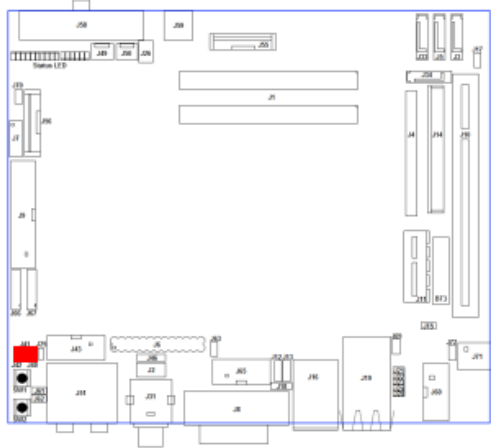

Pin Header	Input
J40	Temp1 (VTIN1)
J41	Temp2 (VTIN2)
J42	Temp3 (VTIN3)

Note: Check the module's BIOS how to enable the baseboard hardware monitor for monitoring temperature and fan revolutions via JIDA32/K-Station or in BIOS HWM setup page.

5.19 FRU-PROM (I2C EEPROM)

Following the new COM Express™ specification the COM Express™ miniBaseboard Type 2 optionally provides an I2C EEPROM. The FRU-PROM (Field Replacable Unit; U154; bottom) at I2C address 07h can be used to store user specific data or baseboard configuration settings. Please contact your local sales or support if this option is needed.

6 Battery Information

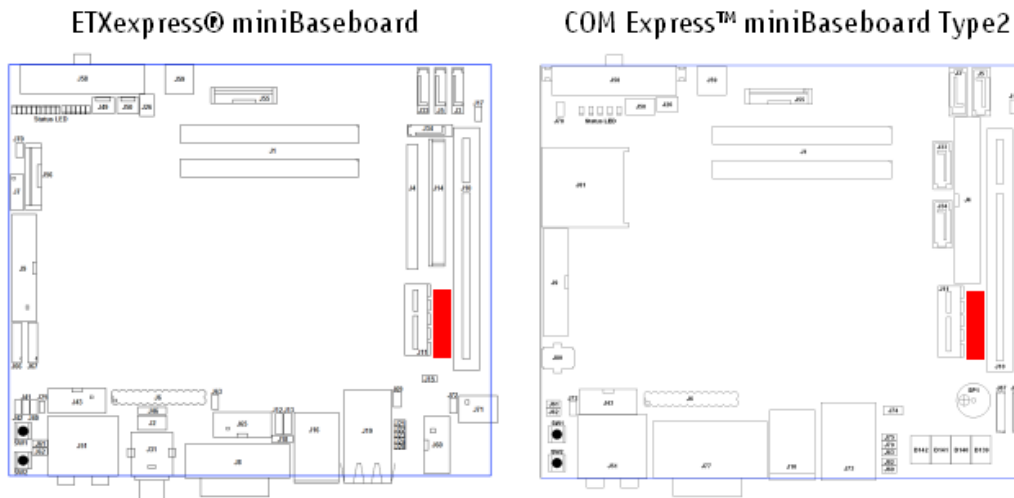

RTC Battery

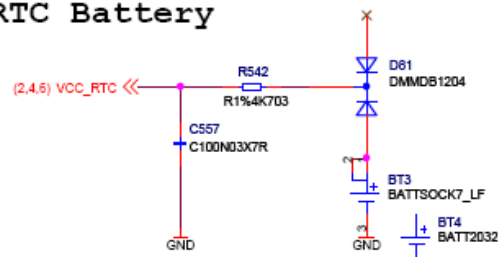

English:

CAUTION: Danger of explosion if battery is incorrectly replaced. Replace only with the same or equivalent type recommended by the manufacturer. Dispose of used batteries according to the manufacturer's instructions.

Deutsch:

VORSICHT: Explosionsgefahr bei unsachgemäßem Austausch der Batterie. Ersatz nur durch denselben oder einen vom Hersteller empfohlenen gleichwertigen Typ. Entsorgung gebrauchter Batterien nach Angaben des Herstellers.

French:

ATTENTION: Risque d'explosion avec l'échange inadéquat de la batterie. Remplacement seulement par le même ou un type équivalent recommandé par le producteur. L'évacuation des batteries usagées conformément à des indications du fabricant.

Danish:

ADVARSEL: Lithiumbatteri – Eksplosionsfare ved fejlagtig Håndtering. Udskifting må kun ske med batteri af samme fabrikant og type. Lever det brugte batteri tilbage til leverandøren.

Finnish:

VAROITUS: Paristo voi räjähtää, jos se on virheellisesti asennettu. Vaihda paristo ainoastaanlaltevalmistajan suosittelemaan tyyppiin. Havita käytetty paristo valmistajan ohjeiden mukaisesti.

Spanish:

Precaución: Peligro de explosión si la batería se sustituye incorrectamente. Sustituya solamente por el mismo o tipo equivalente recomendado por el fabricante. Disponga las baterías usadas según las instrucciones del fabricante.

Note: The battery of this product is not considered to be accessible by the end user. Therefore the safety instructions are only given in English, German, French, Danish, Finnish and Spanish language.

If the battery of this product however is accessible by the end user, it is in the responsibility of the Kontron customer to give the corresponding safety instructions in the required language(s).

7 Single Supply Mode

The miniBaseboard is able to be supplied by just one voltage. This voltage has to be in the range of 8.5V to 18V connected to the 4pin ATX_12V power connector J59.

To use this feature it is as well necessary to have a module supporting the wide range input as some small changes of the assembly (see below). Are these constraints fulfilled, the onboard regulators begin to do the supply instead of the ATX power supply. But some restrictions have to be cared about in this single supply mode.

- » The onboard power regulators for 3.3V and 5V are limited to 6A each. After supplying the onboard devices, there are 4.8A at 3.3V and 5.9A at 5V remaining. Therefore the total current of the used external devices (PCI, PCIexpress, USB, LVDS panel, IDE/CF, RS232/LPT) must not exceed these limits in single supply mode.
- » Additionally no PCI Card can be used, which needs -12V supply.
- » If a wide range power supply is used, the PCI and PCIexpress slots are not supplied with 12V. A LVDS Display has to be supplied separately or with 5V.

Limitations on ETXexpress® miniBaseboard in single supply operation:

- » The FAN1 output voltage on J49 is similar to the input voltage in the range of 8.5V to 12V. For input voltages from 12V to 18V the Fan output is limited to 12V. To fix FAN1 voltage output to 5V place R51 optionally.
- » FAN2 (J50) is not supported except FAN2 voltage output is fixed to 5V by placing R52.

Limitations on COM Express® miniBaseboard Type 2 in single supply operation:

- » Fan (J50) is not supported. Remove FB138 and place at FB137 to enable the Fan output (voltage similar to the input voltage) or place at FB136 for 5V Fan output

Power save mode:

If optional power save mode is enabled (see assembly instructions) the system will shut down after a short time (about 8 seconds) in S5 completely. This means that nearly no power is used from the power supply, because no device will be supplied. But in this case it is only possible to wake up the system by pressing the power button for at least one second.

Note: If power save mode is enabled the baseboard does not start automatically after connecting VCC. Press Power Button SW2 to turn on your system.

7.1 Assembly Instructions ETXexpress® miniBaseboard

Follow the assembly instruction below to enable Single Supply operation:

For correct CPLD supply:

- » Remove R710 (10k0hm; bottom)
- » Mount R705 (100k0hm; bottom)
- » Mount R61 (210k0hm; bottom)

To switch CPLD in single supply mode:

- » Remove R712 (0R; bottom)
- » Mount R711 (1k0hm, bottom)

To enable 5V Standby:

- » Mount R46 (0R; top)
- » Mount R60 (210k0hm; bottom)

To ensure that there is no short with the onboard generated voltages:

- » Remove J58 (top), to ensure, that there is no short with the onboard generated voltages possible.

Optional:

- » Remove R490 (0R, top) and mount on R491 (top) to enable the power save mode
- » FAN1 output is 8.5V -12V. Place R51 (0R; bottom) to fix FAN1 output voltage to 5V
- » FAN2 is not supported. Remove R53 (0R; bottom) and place it on R52 (bottom) to enable FAN2 with +5V output voltage.

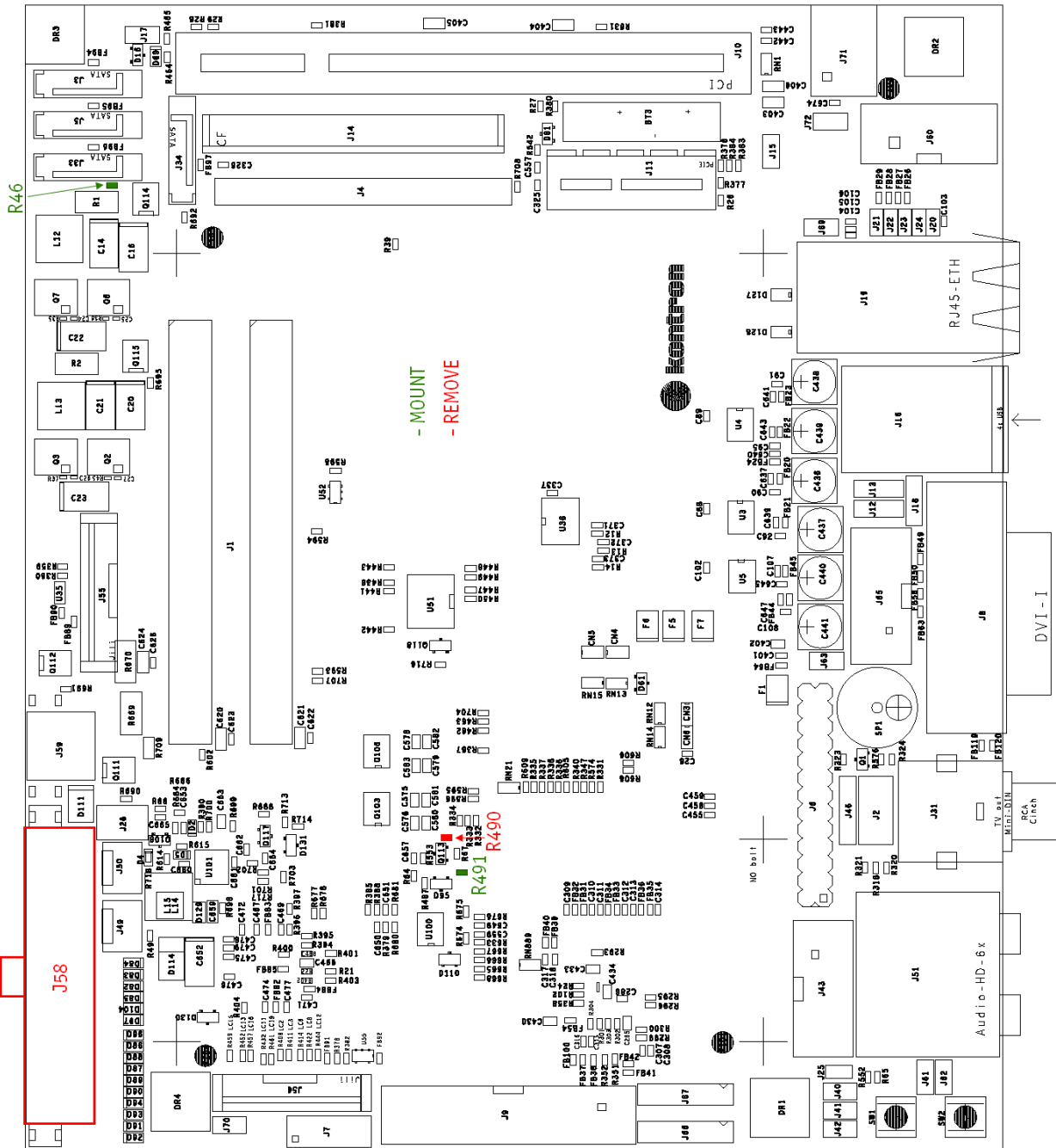

7.2 Assembly Instructions COM Express™ miniBaseboard Type 2

Follow the assembly instruction below to enable Single Supply operation:

To switch CPLD in single supply mode:

- » Remove R712 (0R; bottom)
- » Mount R711 (1k0hm, bottom)

To enable 5V Standby:

- » Mount R46 (0R; bottom)
- » Mount R60 (422k0hm; bottom)

To ensure that there is no short with the onboard generated voltages:

- » Remove J58 (top), to ensure, that there is no short with the onboard generated voltages possible.

Optional:

- » Remove R490 (00hm; top) and mount on R491 (top) to enable the power save mode
- » Fan is not supported. Remove FB138 (Ferrit Chip Bead, 600 Ohm, 1A, 100MHz; bottom) and place it on FB137(bottom) to enable Fan output voltage according to baseboard's input voltage or place it on FB136 to fix Fan output voltage to +5V.

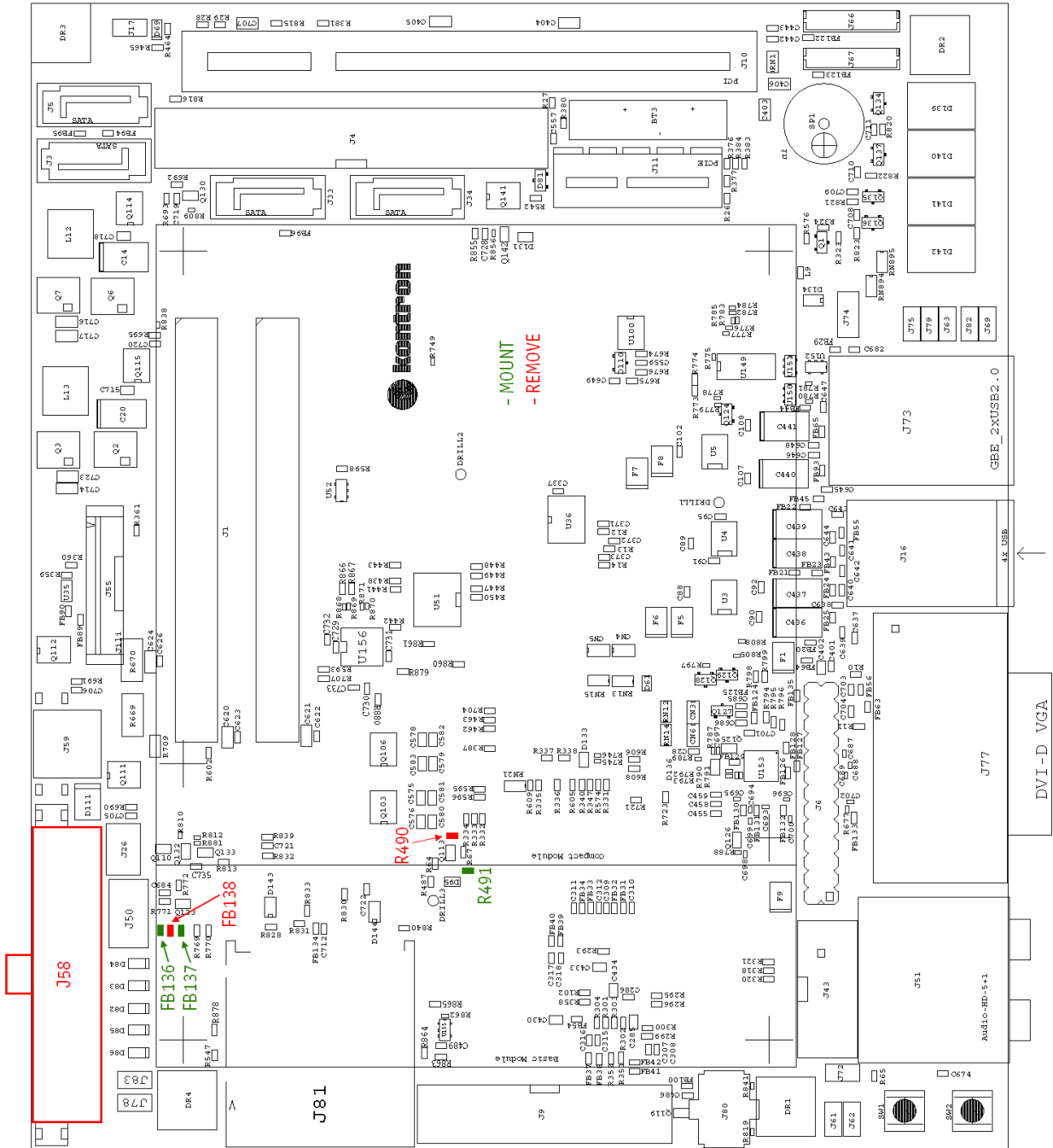

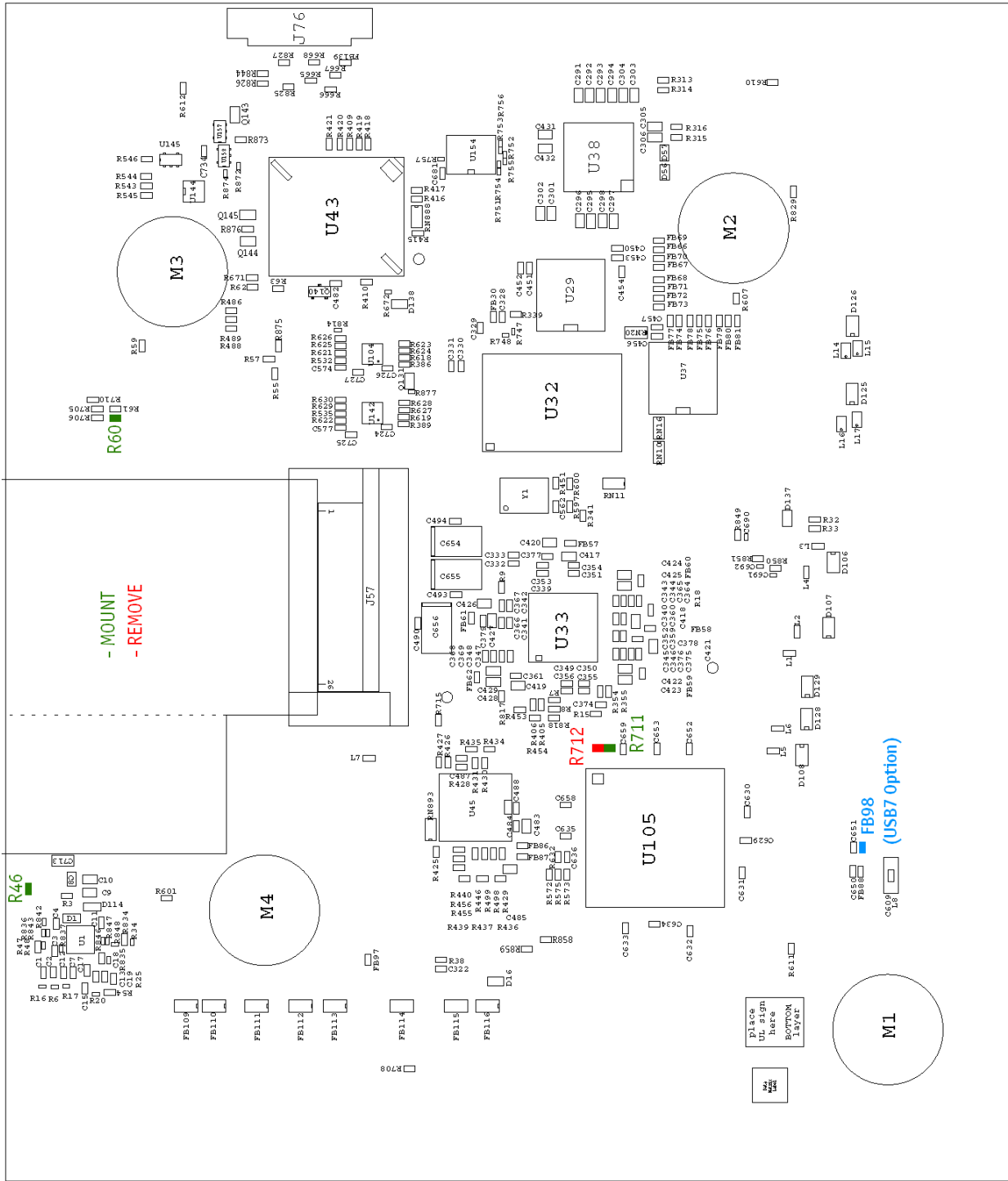

8 Power Distribution ETXexpress® miniBaseboard

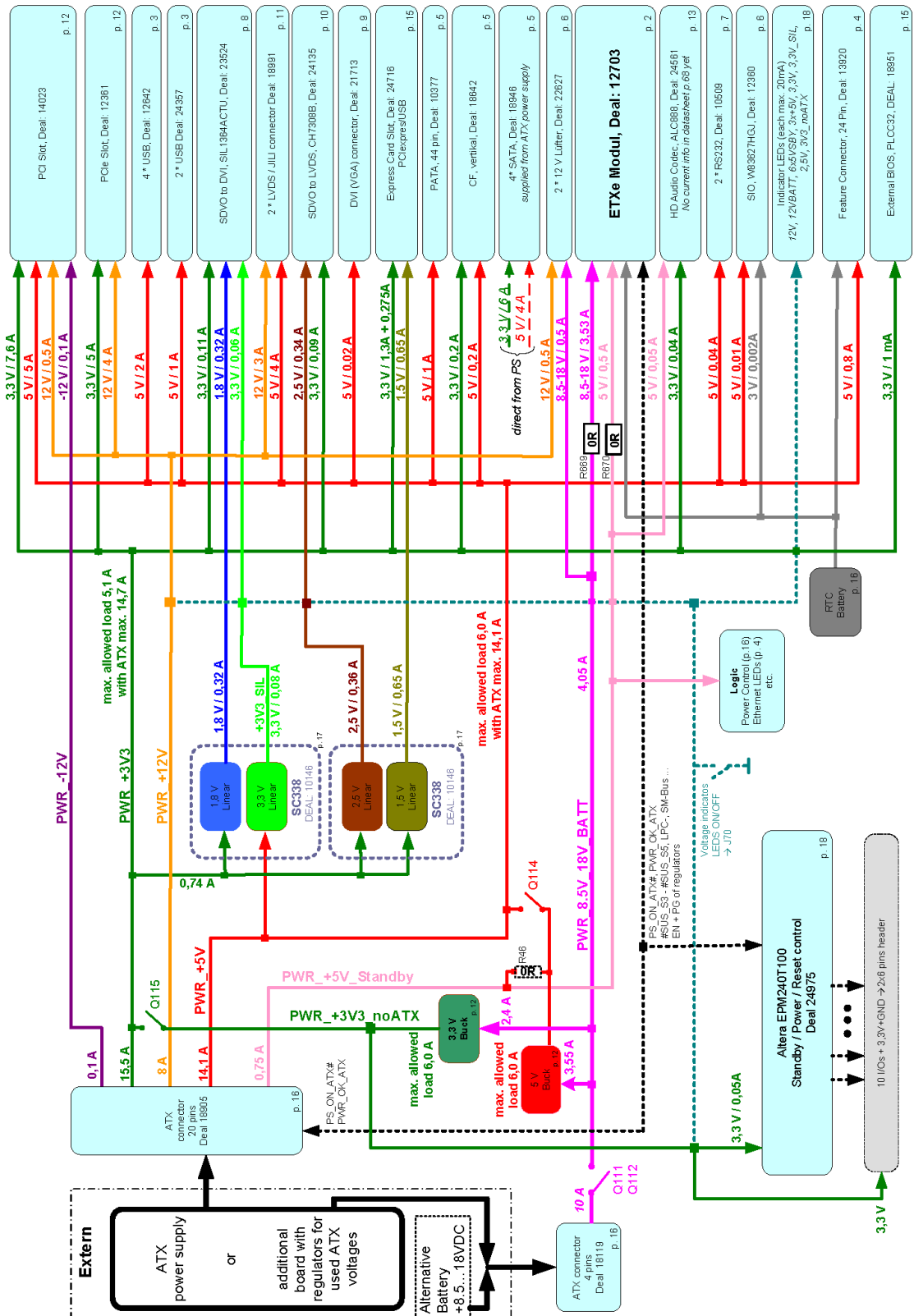

9 Power Distribution COM Express™ miniBaseboard Type 2

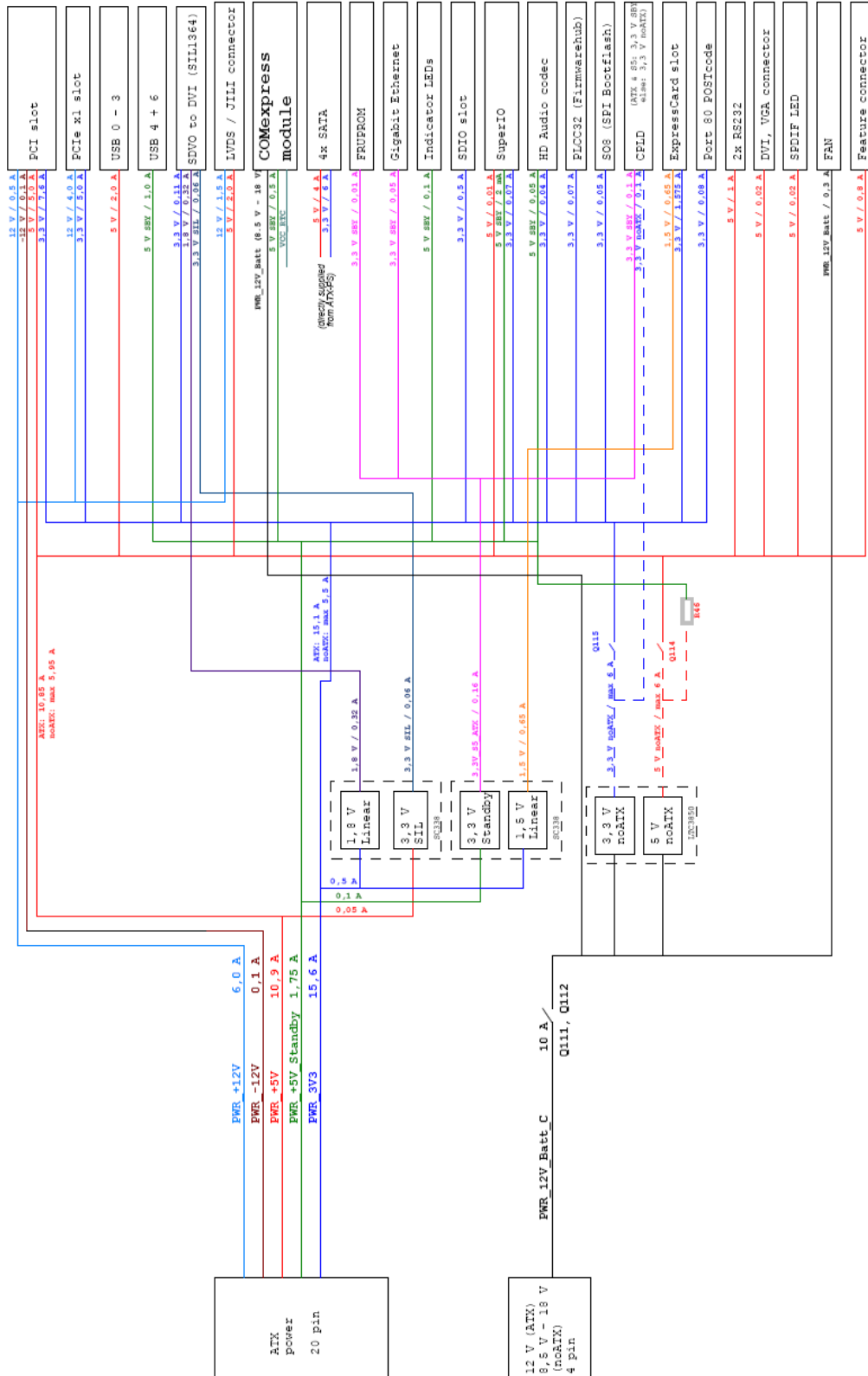

10 Security Advice

To protect the external power lines to peripheral devices the customer has to take care about:

- The wires to the external device have the right diameter to withstand the max. available current
- The housing of the external device fulfils the fire protection requirements of IEC/EN 60950.

11 Appendix C: Document Revision History

Revision	Date	Edited by	Changes
1.0_pre	27.11.2007	PRO	Initial Release
1.0	29.04.2008	PRO	Updated Audio section.
1.1	05.05.2008	PRO	Added Chapter 9 - Limitations and installation hints, J65 USB Pin out table and chapter 11 - Security Advice
1.2	13.05.2008	PRO	Updated Limitations & Support Chapter Corrected Feature Connector
1.3	10.12.2008	PRO	Changed Layout of chapter 5 Corrected Status LED description & Power Connector J59 Corrected some writing errors
2.0	22.06.2010	PRO	Updated document Layout to latest Kontron CI Added descriptons for redesign of ETXexpress miniBaseboard Added MTBF Corrected Status LED of ETXexpress miniBaseboard
2.1	26.07.2010	PRO	Added MTBF for new miniBaseboard
2.2	04.11.2010	PRO	Changed naming of new revision miniBaseboard

Corporate Offices

Europe, Middle East & Africa

Oskar-von-Miller-Str. 1
85386 Eching/Munich
Germany
Tel.: +49 (0)8165/ 77 777
Fax: +49 (0)8165/ 77 219
info@kontron.com

North America

14118 Stowe Drive
Poway, CA 92064-7147
USA
Tel.: +1 888 294 4558
Fax: +1 858 677 0898
info@us.kontron.com

Asia Pacific

17 Building,Block #1,ABP.
188 Southern West 4th Ring
Beijing 100070, P.R.China
Tel.: + 86 10 63751188
Fax: + 86 10 83682438
info@kontron.cn

