

Benutzerinformation
Mikrocomputer
Aufbausystem
CPCI PICMG 2.16-
Einschubsystem 10 HE

User Information
Microcomputer
Packaging Systems
CPCI PICMG 2.16
subrack 10 U

CP-ASM10-PSB



Contents

Contents English, page	1.2
	Page
1 Introduction	1.2
1.1 Please read immediately!	1.2
1.2 Description	1.3
1.3 Safety instructions	1.3
1.4 Advice	1.3
2 System overview	1.4
2.1 Mechanical configuration	1.4
2.2 Assembly	1.5
2.3 Starting-up the system	1.5
2.4 Maintenance	1.5
3 Electrical configuration	1.5
3.1 Cabling, general	1.5
3.2 Fan Control Module (FCM)	1.6
4 Technical data	1.7
4.1 Mechanical data	1.7
4.2 Electrical data	1.7
4.2.1 Power supply	1.7
4.2.2 Fan Control Module (FCM)	1.8
4.2.3 Fan	1.8
4.2.4 Backplane	1.8
4.3 General data	1.8
4.4 Shielding attenuation curve europacPRO	1.9
4.4.1 Measuring principle	1.9
4.4.2 Results	1.9
5 Error correction	1.10
6 Replacement parts	1.10
7 Warranty conditions	1.10

1 Introduction

1.1 Please read immediately!

This microcomputer packaging system is not a complete unit which can be delivered directly to the end user; other items need to be fitted. Before delivering the complete unit, the following checks must be carried out according to the specifications:

- does the assembled unit comply with the safety instructions currently applicable in the country in which it is going to be used?
- are all the apertures of the case closed so that the user cannot get into the case (finger test)?

Make sure that

- all safety checks have been carried out on every unit,
- the operator knows what safety measures have to be undertaken (e.g. GND/earthing),
- the overall unit complies with all other specifications at the place of use and in the country in which it is going to be used, e.g. interference limits, approval by the telecommunications authorities.

The above assumes that the initial testing, completion and final testing of the units have been carried out or at least supervised by qualified technicians. These instructions are directed exclusively to these qualified technicians.

Check the packing content. At least the following should be included:

- 1 bag of assembly parts for mounting the system subrack into a case or cabinet

When the unit has been unpacked the safety and function checks should be carried out immediately, see section "Introduction – Safety instructions". No liability is accepted for boards which have been destroyed by faulty operating voltages!

If there are problems please contact your supplier or your local Schroff representative, see back cover of this booklet.

1.2 Description

This microcomputer system consists of mechanics, backplane, fan and power supply for a microprocessor system based on the CPCI PICMG2.16bus. This microcomputer packaging system has been designed for use in laboratories or in a manufacturing environment where there are no extreme conditions.

Please check the technical data of any parts which you wish to assemble; they may restrict the air flow and the temperature.

This unit has no valid approval for the complete unit. This can only be granted for the complete unit if approval is granted for individual units or a batch. Such approvals are carried out by VDE, TÜV, professional boards etc. according to each application.

CAUTION!

The unit is designed in accordance with protection class 1!
It must therefore be operated only with protective GND/earth connection!

1.3 Safety instructions

This microcomputer packaging system has been subjected to extensive testing before delivery. However, this cannot guarantee that the unit does not get damaged during transit. Check the packaging and the CPCI unit before applying mains voltage to ensure that your system can not be destroyed by faulty operating voltages.

Caution:

The area of the system accessed after removing the mains/line panels is not a user area! Parts which can be touched may be exposed to dangerous voltages. Initial testing, completion, final testing or maintenance and repairs must be carried out by trained engineers only.

The following tests have to be done before placing the system in service:

Disconnect the main/line voltage!

At the rear:

- Open the fuse holder with a screwdriver.
- Is the correct fuse fitted?
- The fuse value has been determined at the factory for the maximal power delivered by the power supply. The fuse value must be adjusted to the real current of the global system. Maximum values are 5 A slow.

At the front:

- Are front panels mounted to all connector positions and disk drive apertures?
- Are fan front panel and power supplies screwed on securely?

1.4 Advice

Caution:



Attention

- please observe the safety instructions
- read operating instructions before system start-up!
- to be operated only on networks with PE conductor!
- put into service by qualified personnel only!

Safety instructions



Danger to life

are meant to

- save lives
- prevent accidents
- save trouble

Please make sure to keep these operating instructions. They contain valuable information pertaining to safety.

They

- support operators, users, service staff and technical personnel during preparatory work, installation and system start-up, and they help understand the functions of the system
- give hints as to special operating conditions
- explain the displays and control elements
- inform about all essential technical data

Technical changes and upgrades will be implemented without prior announcement, provided that they serve technical progress.

This product is intended exclusively for commercial and industrial applications. It is not designed for use in connection with life-supporting medical equipment or other critical applications.

This documentation has been prepared and checked with greatest care. However, we cannot give guarantee for its complete correctness, for any damage resulting from misprint or improper use.

In the case of improper use all warranty claims will lapse!

2 System overview

2.1 Mechanical configuration

- 1 Chassis
- 2 Two power supplies in the top section
- 3 Slot for two power supplies in the bottom section
- 4 Two slots for CMMs
- 5 Subrack
- 6 Air entry with fan tray and air filter
- 7 Backplane
- 8 Cableing
- 9 Mains/line connection
- 10 Rear-I/O

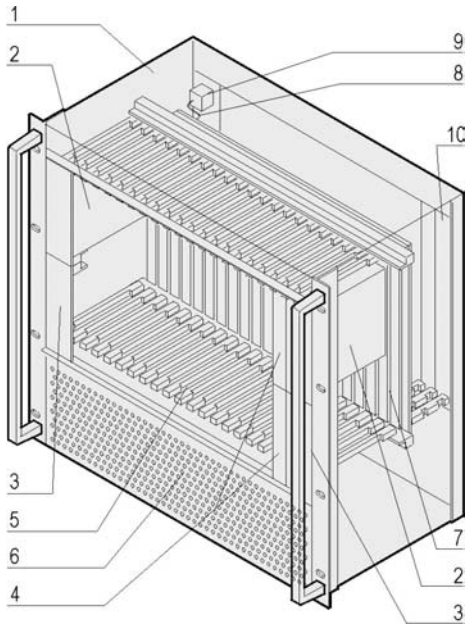

Front view:



10001002

2.2 Assembly

The subrack can be equipped with 6 U/ 4 F CPCI PICMG 2.16 boards on the front and 6 U/ 4 F boards with rear I/O on the back. Boards are mounted in guide rails and fixed with collar screws. The guide rails for the system slot are red. The blue guide rails characterize the Fabric slots. Up to four 3 U CPCI power supplies can be integrated using the green guide rails.

For optimal heat dissipation, unused 6 U slots must be closed with air flow barrier front panels, unused power supply slots with front panels.

The subrack can be mounted on the cabinet's upright using the eight M6 screws.

2.3 Starting-up the system

The mains/line fuse value must be adjusted to the actual current consumption of the complete system. Connect the system to the mains/line and switch it on by using the mains/line switch. Green LEDs on the power supplies indicate that the voltages exist. Red LEDs indicate a fault.

2.4 Maintenance

In order to remove the fan modules, loosen the collar screws and hinged the front panel (Position 6, chapter Mechanical construction). A faulty fan can be replaced while the system is operating. The air filter is accessible underneath the fan tray. The filter must be changed regularly, depending on the environmental conditions.

3 Electrical configuration

3.1 Cabling, general

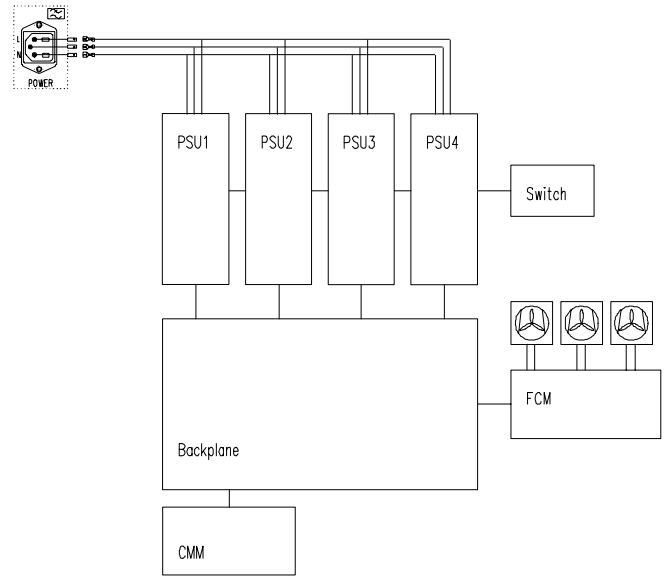

10002500

3.2 Fan Control Modul (FCM)

The Fan Control Module, based on a microcontroller, monitors up to 4 DC fans rotation speed depending on the temperature. Up to 4 temperature sensors (NTC) can be connected. It controls the theoretical speed value of each fan. If the fan speed falls below the theoretical value or by cable damage or by temperature sensor cable short-circuit, an alarm is generated and the fans rotate at their maximum speed. The FCM has a CMM connection (I2C-bus) for remote alarm signal and for individual configuration of the FCMs.

Block diagram:

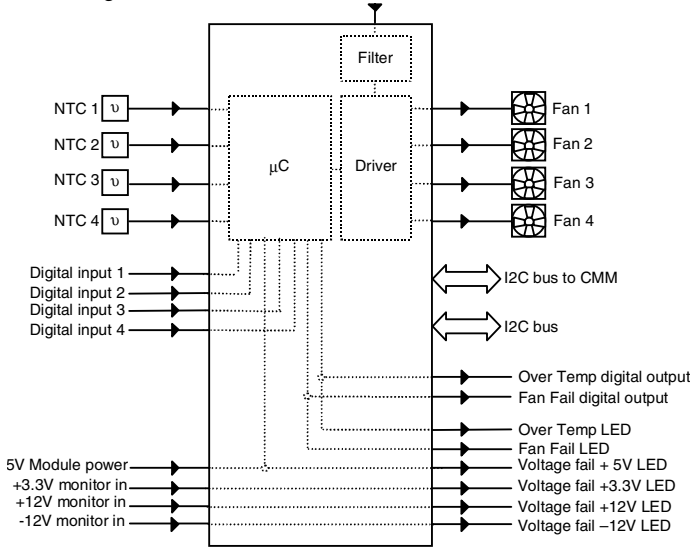

10002501

Fan speed characteristics:

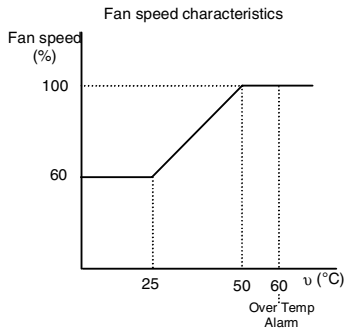

Pin assignment:

X1: Connector for signals and power supply

Designation	Terminal	Function
12V	1	Power for fan; Current: 3A
-12V	8	Ground for fan Current: 3A
12V	2	LED display
-12V	9	LED display
3,3V	3	LED display
5V	10	Power for logic current: 0,5A
GND	11	Ground for logic current: 1A
Temp Fail collector	4	Signal out
Temp Fail emitter	5	Signal out Ground
Fan Fail collector	6	Signal out
Fan Fail emitter	7	Signal out Ground
CMM BUS SCL	13	Communication Bus
CMM BUS SDA	12	Communication Bus
CMM BUS GND	14	Communication Bus

X2: Connector for temperature sensors and digital inputs

Designation	Terminal	Function
Digital in1 TTL	7	Signal in
Digital in2 TTL	8	Signal in
Digital in3 anode	9	Signal in
Digital in3 cathode	10	Signal Ground
Temp1 +	1	Temp sensor
Temp1 -	2	Temp sensor
Temp2 +	3	Temp sensor
Temp2 -	4	Temp sensor
Temp3 +	5	Temp sensor
Temp3 -	6	Temp sensor

4 Technical data

4.1 Mechanical data

In accordance with IEC 60297, IEEE 1011.10/11

Dimensions

H x W x D = 445mm (10 U) x 483mm (19") x 325mm

Weight (without boards)

20 kg

Heat dissipation

Provided by three axial fans.

Maximum air capacity 275 m³/h.

Average temperature increase in subrack at full load 12 K.

The fan speed depends on the temperature. The speed control occurs between 20°C and 45°C, in a range of 60% to 100% of the maximum speed.

100 02 502

+X

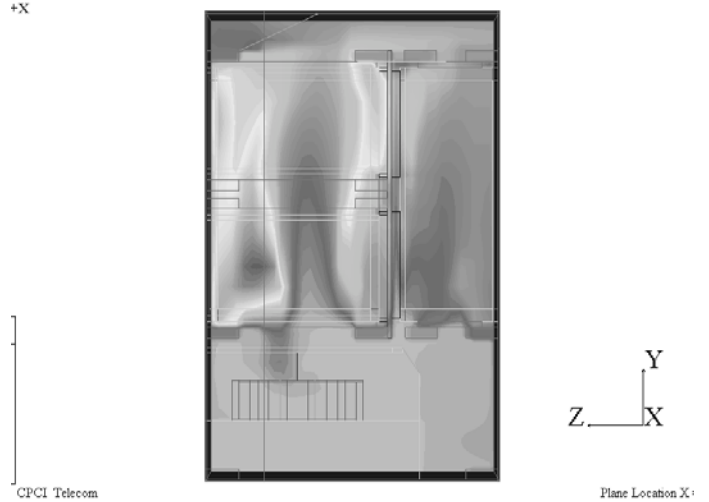

4.2 Electrical data

4.2.1 Power supply

Data of a single power supply:

Mains/line voltage (operating ranges)	85-264Vac	
Frequency	47-63Hz	
Switch-on current	max.12A	
Output power max.	250W	
Output voltages: max. individual current	+ 5 V +3,3V + 12 V - 12 V	40 A 40A 5,5A 1,5A
Residual ripple	2%	
Dynamic load variation 50%->100%	1%	
Control time after switch-on	150ms	
Mains / line buffer	20ms	

4.2.2 FCM (Fan Control Module)

Supply voltage	+5V
Input current	500mA
Dimensions	38mm x 160mm x 25mm (L x W x D)
Interface	4 digital inputs TTL level
	2 digital outputs, galvanical separation with optocoupler
	4 counter inputs for fan monitoring
	Supply for up to four fans max. 2,5A
	8 measuring inputs NTC
	Interface for CMM via I ² C-bus

4.2.3 Fan

Nominal voltage	24 V _{DC}
Current consumption	3 x 0,68A
Air volume, unrestricted	3 x 294 m ³ /h
Speed	3800 tr.min ⁻¹
Tachometer output	Two pulses per revolution
Dimensions	127mm x 127mm x 38mm

4.2.4 Backplane

Technical data etc., see Backplane user information.

4.3 General data

Fuse (max. value)

10 A slow 250V

Test voltages to EN 60950

Input-Output	4,3 KV _{DC}
Input - PE	2,2 KV _{DC}
Output - PE	0,7 KV _{DC}
Output - Output	0,7 KV _{DC}

Approvals

Component	VDE	UL
Mains/line connector	*	*
Mains/line switch	*	*
Power supply	*	*

Ambient temperature

Service	0 °C+ 40 °C
Storage	- 40 °C ...+ 85 °C

Humidity

30 – 80 %, no condensation

Shock and vibrations

according to EN 60068-2-6 and EN 60068-2-27

Protection: IP 20

Overvoltage category II

Protection class 1

Safety

The unit supplied by Kontron complies with EN 60950

Electromagnetic Compatibility EMC

Typical attenuation of 40 dB for 1 GHz, if shielded front panels are used.

By assembling additional electronic components the safety and EMC data may change.

The complete system must then be re-tested to maintain the stated performance.

Electromagnetic Compatibility EMC

This microcomputer packaging system is not a complete unit. Further items need to be fitted. According to the definition of the EMC legislation this is not classed as a unit. The CE symbol has therefore not to be used.

The systems fulfill however all conditions, in order to comply, in the developed condition, with the EMC guideline 89/336/EWG and the low-voltage guideline 73/23/EWG. The systems are generally equipped with power supply units which display a CE symbol.

The selection of the A/C line filter is in consideration of the limit value curve according to EN55022 class B. In-house measuring instruments permit a precise selection of the filters.

In order to be prepared to the interference immunity according to EN61000-6-2, absorption measurements are accomplished by Schroff while designing subracks and cases. These measurements cover the frequency range from 30 MHz to 1000 MHz according to VG 95 373, part 15.

4.4 Shielding attenuation curve europacPRO

4.4.1 Measuring principle

The shielding attenuation is achieved by measuring the losses of the testpiece. First measure the field intensity level A_0 of the receiver on no-load (fig. 2a, without case), then the field intensity level A_1 with a case (fig. 2b). The difference gives you the shielding attenuation. Calibrating the receiver is not necessary, as the field intensity level A_0 can be considered as a reference.

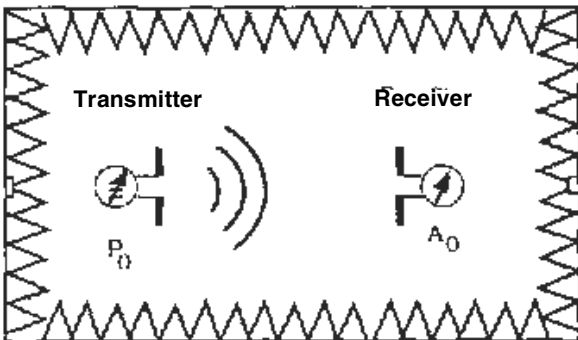

Fig. 2a

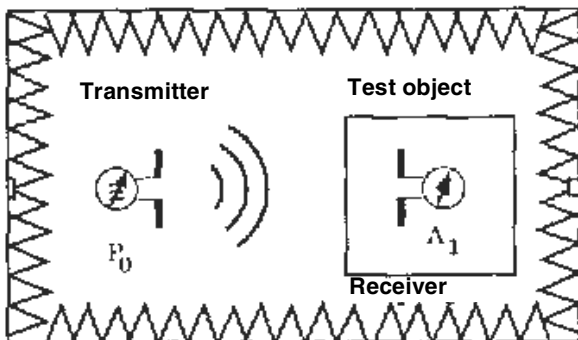

Fig. 2b

Measuring the shielding attenuation (principle).

- a) Measure without testpiece,
- b) Measure with testpiece.

Shielding attenuation calculation a_s ,

$$a_s = A_0 - A_1 \text{ in dB.}$$

4.4.2 Results

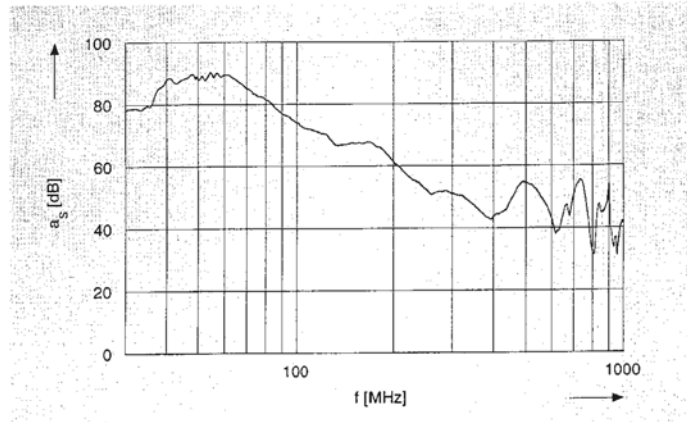

Shielding attenuation in the range of 30 MHz to 1 GHz, Subrack europacPRO, textil contact strip Radiation on the front panel, vertical polarisation.

5 Error correction

Error	Cause	Corrective measure
Neither the red nor the green LED of the power supply is on	No mains/line voltage	Check the mains/line cable
The red LED of one power supply is on	Faulty power supply	Replace the power supply unit

6 Replacement parts

Replacement parts	Order no.
CP3-CMM1	25936
Power supply CP3-SVE-P200AC	23632
Slots cover, 6 U	19824
	19825

7 Warranty conditions

Duration

This Microcomputer Packaging System has a warranty of 2 years. The warranty begins on the day of delivery.

Cover of defects

Within the warranty period Kontron will repair free of charge any malfunctioning of the Microcomputer Packaging System resulting from faulty design or defective material. All other claims under the warranty are excluded, in particular consequential damage.

Warranty exclusion

The warranty does not cover damage or functional defects caused by non-adherence to the Company's User Information or such caused by dropping, knocking, contamination or other untoward handling. The warranty is invalidated if the Microcomputer Packaging System is not checked for safety and function in accordance with Section 1.1 of this User Information leaflet immediately after unpacking, if it is tampered with or the serial number on the packaging system is changed or rendered illegible.

Claims under warranty

This Microcomputer Packaging System has been carefully checked and adjusted. If you have a valid claim and in order to make a claim under the warranty, ensure that the following is carried out:

- Include a detailed description of the fault.
- The Microcomputer Packaging System should be returned in the original carton or similar packaging, insured and post paid.

Inappropriate handling will invalidate the warranty!

This documentation has been compiled and checked with the utmost care. We cannot, however, ensure its correctness in every respect.