

» Kontron User's Guide «

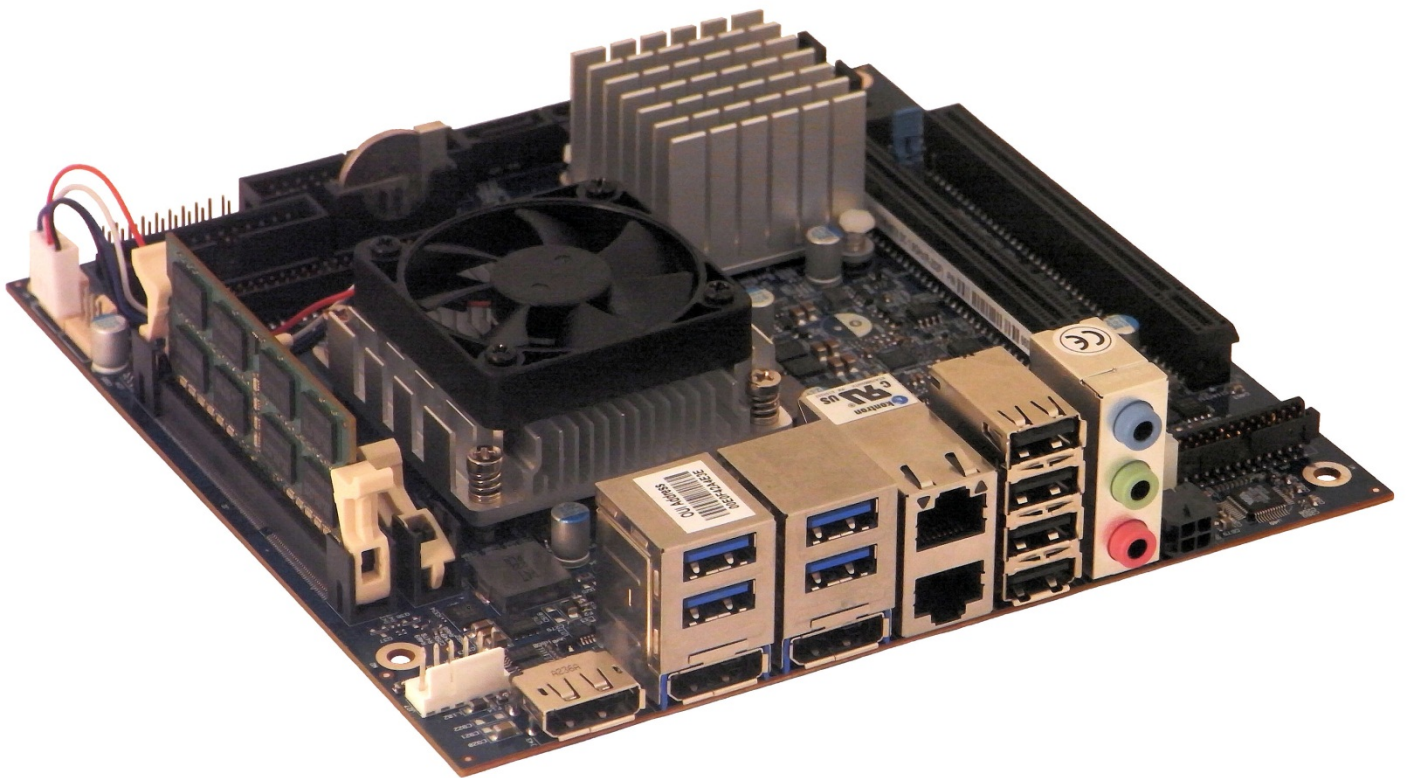

KTA70M/mITX

KTD-N0861-D

» Table of Contents «

1	Introduction	1
2	Installation Procedure	2
2.1	Installing the Board	2
2.2	Requirements IEC60950	3
2.3	System memory support	4
3	System Specifications	5
3.1	Component main data	5
3.2	KTA70M/mITX Block Diagram	9
3.3	Power Consumption	10
3.4	USB ports overview	12
4	Connectors Locations.....	14
4.1	KTA70m/mITX Topview	14
4.2	KTA70m/mITX Bottomview	15
5	Connector Signal Definitions	16
6	Rear IO Connectors.....	17
6.1	DisplayPort (DP0/DP1/DP2)(J4/J43/J3).....	17
6.2	USB3.0 Connectors (USB10/USB11/USB12/USB13)(J15/J15/J14/J14).....	19
6.3	Ethernet Connectors (ETH1/ETH2) (J8).....	21
6.4	USB x4 Stack Connector (USB6/USB7/USB8/USB9) (J20)	22
6.5	Audio Interface (J40).....	23
6.6	DC Power External Connector (J28)	24
7	Pin Connectors	25
7.1	DC Power Internal Connector (J19)	25
7.1	12V-SB-In Connector (J31)	25
7.2	Audio Header Connector (J41)	26
7.3	Power Out Connector (J18).....	27
7.4	USB4/5 Connector (J16).....	28
7.5	Jumper area (J34, J35, J36, J37)	29
7.6	SPI Connector (J21).....	30
7.7	COM1/COM2 (J23/J22).....	31
7.8	LPC Connector (J29).....	32
7.9	Front Panel Connector (J5).....	33
7.10	CPU/System Fan Connectors (J25, J24)	34
7.11	Feature Connector (J26)	35
7.12	KBD/MSE (J27)	38
8	Slot Connectors (PCI-Express, miniPCIe, SATA, mSATA).....	39

8.1	PCIex8 (in x16 slot) (J7)	39
8.2	PCIex4 (J6).....	41
8.3	mPCIe connector (J38)	43
8.4	SATA0, SATA1, SATA2, SATA3, SATA4 (J12, J13, J9, J11, J10)	44
8.5	mSATA Connector (J39)	45
9	BIOS.....	46
9.1	Main	46
9.2	Advanced.....	47
9.2.1	Advanced - PCI Subsystem Settings.....	48
9.2.2	Advanced - APCI Settings	51
9.2.3	Advanced - Trusted Computing	52
9.2.4	Advanced - CPU Configuration	53
9.2.5	Advanced - IDE Configuration.....	55
9.2.6	Advanced - USB Configuration.....	56
9.2.7	Advanced - Super IO Configuration	57
9.2.8	Advanced - Hardware Health Configuration.....	60
9.2.9	Advanced - LAN Configuration	62
9.2.10	Advanced - PCI-E Port	63
9.2.11	Network Stack.....	64
9.3	Chipset.....	65
9.3.1	South Bridge	66
9.3.2	North Bridge	71
9.4	Boot	75
9.4.1	CSM parameters	77
9.5	Security.....	78
9.6	Save & Exit.....	79
10	AMI BIOS Beep Codes.....	80
	Appendix: Mating Connectors	81
	Appendix: OS Setup	82

Document Revision History

Rev.	Date	By	Comment
D	04/2016	GSZ	New memory SKU
C			Remove help text in Socket 0 Information. EXT_BAT max. 3.47 V.
B	Nov 7 th 2013	MLA	Correction of footer text in appendix. System Specification PCIe info improved. Added "Power Consumption" and BIOS part. Updated KTA70M variants.
A	Feb 22 nd 2013	MLA	New Pictures and minor corrections.
0	Jan 7 th 2013	MLA	Preliminary version

Copyright Notice

Copyright © 2013, KONTRON Technology A/S, ALL RIGHTS RESERVED.

No part of this document may be reproduced or transmitted in any form or by any means, electronically or mechanically, for any purpose without the express written permission of KONTRON Technology A/S.

Trademark Acknowledgement

Brand and product names are trademarks or registered trademarks of their respective owners.

Disclaimer

KONTRON Technology A/S reserves the right to make changes without notice to any product, including circuits and/or software described or contained in this manual in order to improve design and/or performance.

Specifications listed in this manual are subject to change without notice. KONTRON Technology assumes no responsibility or liability for the use of the described product(s), conveys no license or title under any patent, copyright or mask work rights to these products and makes no representations or warranties that these products are free from patent, copyright or mask work right infringement unless otherwise specified. Applications that are described in this manual are for illustration purposes only. KONTRON Technology A/S makes no representation or warranty that such application will be suitable for the specified use without further testing or modification.

Life Support Policy

KONTRON Technology's PRODUCTS ARE NOT FOR USE AS CRITICAL COMPONENTS IN LIFE SUPPORT DEVICES OR SYSTEMS WITHOUT EXPRESS WRITTEN APPROVAL OF THE GENERAL MANAGER OF KONTRON Technology A/S.

As used herein:

Life support devices or systems are devices or systems which (a) are intended for surgical implant into body or (b) support or sustain life and whose failure to perform when properly used in accordance with instructions for use provided in the labelling can be reasonably expected to result in significant injury to the user.

A critical component is any component of a life support device or system whose failure to perform can be reasonably expected to cause the failure of the life support device or system or to affect its safety or effectiveness.

KONTRON Technology Technical Support

If you have questions about installing or using your KONTRON Technology Product, then check this User's Manual first – you will find answers to most questions here. To obtain support please contact your local Kontron Sales Partner or Kontron Field Application Engineer (FAE).

Before Contacting Support: Please be prepared to provide as much information as possible:

- CPU Board

1. Type and P/N (Part Number), find label like:

KTA70M/mITX QC 2.0GHz(R-460L) P/N:  66010000

2. S/N (Serial Number), find label like:

Prod.code:D6P S/N:  01111336

- Configuration (if relevant)

1. CPU Type and Clock speed
2. DRAM Type and Size.
3. BIOS Revision (find the version info in the BIOS Setup Menu).
4. BIOS Settings different than *Default* Settings.

- System (if relevant)

1. OS (Operating System) Make and Version.
2. Driver Version numbers: Graphics, Network, and Audio etc.
3. Attached Hardware: Harddisks, CD-Rom, Display Panels etc.

If the Kontron Technology product seems to be defect and you want to return it for repair, please follow the guide lines from the following page:

<http://kontron.com/services/rma-information/kontron-technology-a-s/>

Warranty

KONTRON Technology warrants its products to be free from defects in material and workmanship during the warranty period. If a product proves to be defective in material or workmanship during the warranty period KONTRON Technology will, at its sole option, repair or replace the product with a similar product. Replacement Product or parts may include remanufactured or refurbished parts or components.

The warranty does not cover:

1. Damage, deterioration or malfunction resulting from:
 - A. Accident, misuse, neglect, fire, water, lightning or other acts of nature, unauthorized product modification or failure to follow instructions supplied with the product.
 - B. Repair or attempted repair by anyone not authorized by KONTRON Technology.
 - C. Causes external to the product, such as electric power fluctuations or failure.
 - D. Normal wear and tear.
 - E. Any other causes which does not relate to a product defect.
2. Removal, installation and set-up service charges.

Exclusion of damages:

KONTRON TECHNOLOGY LIABILITY IS LIMITED TO THE COST OF REPAIR OR REPLACEMENT OF THE PRODUCT. KONTRON TECHNOLOGY SHALL NOT BE LIABLE FOR:

1. DAMAGE TO OTHER PROPERTY CAUSED BY ANY DEFECTS IN THE PRODUCT, DAMAGES BASED UPON INCON- VENIENCE, LOSS OF USE OF THE PRODUCT, LOSS OF TIME, LOSS OF PROFITS, LOSS OF BUSINESS OPPORTUNITY, LOSS OF GOODWILL, INTERFERENCE WITH BUSINESS RELATIONSHIPS OR OTHER COMMERCIAL LOSS, EVEN IF ADVISED OF THEIR POSSIBILITY OF SUCH DAMAGES.
2. ANY OTHER DAMAGES, WHETHER INCIDENTAL, CONSEQUENTIAL OR OTHERWISE.
3. ANY CLAIM AGAINST THE CUSTOMER BY ANY OTHER PARTY.

1 Introduction

This manual describes the KTA70M/mITX family of boards made by KONTRON Technology A/S. These board will also be denoted KTA70M within this Users Guide.

The KTA70M family is based on AMD eTrinity platform: AMD BGA FP2 processor APU and AMD Fusion controller Hub A70M (Hudson M3) on a mini ITX form factor. See the chapter *System Specifications* for more specific details.

The KTA70M family consist on three members having the same functionality except for different BGA processors (soldered to the board). The 3 versions have the same type of active CPU cooler premounted.

KTA70M variants	Sales PN	Processor data
KTA70M/mITX QC 1.9GHz(R-460H)	810524-4500	1.9/2.8 GHz – Quad Core – 35W
KTA70M/mITX QC 2.0GHz(R-460L)	810520-4500	2.0/2.8 GHz – Quad Core – 25W
KTA70M/mITX DC 1.9GHz(R-252F)	810522-4500	1.9/2.4 GHz – Dual Core – 17W

Use of this Users Guide implies a basic knowledge of PC-AT hard- and software. This manual is focused on describing the KTA70M board's special features and is not intended to be a standard PC-AT textbook.

New users are recommended to study the *Installation Procedure* stated in the following chapter before switching-on the power.

All configuration and setup of the CPU board is either done automatically or manually by the user via the BIOS setup menus. Only exceptions are the *Clear CMOS jumper* and the *Always On jumper*.

Latest revision of this manual, datasheet, BIOS, drivers, BSP's (Board Support Packages), Mechanical drawings (2D and 3D) can be downloaded from here:

<http://kontron.com/products/boards+and+mezzanines/embedded+motherboards/miniitx+motherboards/hta70mmitx.html>

2 Installation Procedure

2.1 Installing the Board

To get the board running, follow these steps. If the board shipped from KONTRON has already components like RAM mounted, then relevant steps below can be skipped.

1. Turn off the PSU (Power Supply Unit)



Warning: Turn off PSU (Power Supply Unit) before configuring the board and do not hot plug power supply, otherwise components (RAM, LAN cards etc.) might get damaged.

2. Insert the DDR3 SODIMM 204pin module(s)

Be careful to push it in the slot(s) before locking the tabs.

3. Connecting Interfaces and PSU

Insert all external cables for hard disk, keyboard etc. A display/monitor must be connected in order to be able change BIOS settings. Connect 12V +/-5% PSU to the board via one of the two types of 4-pin power connectors (both located next to the Audio Jack stack connector).

4. Power Button

Turn on mains power to the PSU. If board doesn't boot, then PWRBTN_IN must be toggled; this is done by shorting pins 16 (PWRBTN_IN) and pin 18 (GND) on the FRONTPNL connector (see Connector description), by use of a "normally open" switch etc.

5. BIOS Setup

Enter the BIOS setup by pressing the key during boot up. Enter Exit Menu and Load Optimal Defaults. Refer to the "BIOS Configuration / Setup" section of this manual for details on BIOS setup.

Note: To clear all BIOS settings, including Password protection, activate "Clear CMOS" Jumper for ≈10 sec (without power connected).

6. Mounting the board to chassis



Warning: When mounting the board to chassis etc. please notice that the board contains components on both sides of the PCB which can easily be damaged if board is handled without reasonable care. A damaged component can result in malfunction or no function at all.

When fixing the Motherboard on a chassis it is recommended using screws with integrated washer and a diameter of ≈7mm. Do not use washers with teeth, as they can damage the PCB and cause short circuits.

2.2 Requirements IEC60950

Take care when designing chassis interface connectors in order to fulfil the IEC60950 standard.

When an interface or connector has a VCC (or other power) pin which is directly connected to a power plane like the VCC plane:

To protect the external power lines of the peripheral devices the customer has to ensure:

- Wires have suitable rating to withstand the maximum available power.
- That the enclosure of the peripheral device fulfils the fire protecting requirements of IEC60950.

Lithium battery precautions

<p style="text-align: center;">CAUTION!</p> <p>Danger of explosion if battery is incorrectly re- placed. Replace only with same or equivalent type recommended by manufacturer. Dispose of used batteries according to the manufacturer's instruc- tions.</p>	<p style="text-align: center;">VORSICHT!</p> <p>Explosionsgefahr bei unsachgemäßem Austausch der Batterie. Ersatz nur durch den selben oder einen vom Hersteller empfohlenen gleichwertigen Typ. Entsorgung gebrauchter Batterien nach Anga- ben des Herstellers.</p>
<p style="text-align: center;">ATTENTION!</p> <p>Risque d'explosion avec l'échange inadéquat de la batterie. Remplacement seulement par le même ou un type équivalent recommandé par le producteur. L'évacuation des batteries usagées conformément à des indications du fabricant.</p>	<p style="text-align: center;">PRECAUCION!</p> <p>Peligro de explosi3n si la batera se sustituye incorrectamente. Sustituya solamente por el mismo o tipo equivalente recomendado por el fabricante. Disponga las bateras usadas segun las instrucciones del fabricante.</p>
<p style="text-align: center;">ADVARSEL!</p> <p>Lithiumbatteri – Eksplosjonsfare ved feilagtig hndtering. Udskiftning m kun ske med batteri af samme fabrikat og type. Levér det brugte batteri tilbage til leverandøren.</p>	<p style="text-align: center;">ADVARSEL!</p> <p>Ekspl3sjonsfare ved feilaktig skifte av batteri. Benytt samme batteritype eller en tilsvarende type anbefalt av apparatfabrikanten. Brukte batterier kasseres i henhold til fabrikantens instruksjoner.</p>
<p style="text-align: center;">VARNING!</p> <p>Explosionsfara vid felaktigt batteribyte. Anvnd samma batterityp eller en ekvivalent typ som rekommenderas av apparattillverkaren. Kassera anvnt batteri enligt fabrikantens instruktion.</p>	<p style="text-align: center;">VAROITUS!</p> <p>Paristo voi rjhtää, jos se on virheellisesti asennettu. Vaihda paristo ainoastaan latteval- mistajan suosittelemaan tyyppiln. Hvitä käytetty paristo valmistajan ohjeiden mukaisesti.</p>

2.3 System memory support

Notes: Kontron offers the following DDR3 204P SODIMM:

NEW SKU* 04/2016	SKU Name**	OLD SKU before 04/2016
1060-2502	DDR3-1066 SODIMM 1GB	1054-3773
1060-2508	DDR3-1066 SODIMM 2GB	1054-3777
1060-2510	DDR3-1066 SODIMM 4GB	1054-3778
1060-2512	DDR3-1333 SODIMM 2GB	1054-3781
1060-2518	DDR3-1333 SODIMM 2GB	1055-8136
1060-2514	DDR3-1333 SODIMM 4GB	1054-3782
1060-2516	DDR3-1333 SODIMM 8GB	1054-3783
1060-2506	DDR3-1600 SODIMM 1GB	1054-3776
1060-2482	DDR3-1600 SODIMM 2GB	1051-5403
1060-2484	DDR3-1600 SODIMM 4GB	1051-9057
1060-2504	DDR3-1600 SODIMM 8GB	1054-3775

*SKU changes were caused by administrative issues only, no hardware changes.

**Named are always the min. requirements, the shipped memory can fulfill a higher performance level

3 System Specifications

3.1 Component main data

The table below summarizes the features of the KTA70M/mITX embedded motherboards.

Form factor	mITX (miniITX): 170,18 x 170,18 mm / 6,7 x 6,7"
Processor	<p>AMD eTrinity FP2 processor:</p> <ul style="list-style-type: none"> • Quad-Core 2.0/2.8 GHZ with R-460L APU 25W • Quad Core 1.6/2.4GHz with R-452-L APU 19W • Dual Core 1.9/2.4GHz, with R-252F APU 17W • Compatible with Existing 32-Bit x86 and 64-bit AMD64 Code Base • AMD64 64-bit ISA • High Performance Floating-Point Unit • SSE 4.1 & 4.2, AVX 1.0 & 1.1, AES, XOP, FMA4 • Secure advanced Virtualization Features • 64-bit DDR3 SDRAM Controller (1333MT/s,666MHz): PC3-10600 • Compliant with JEDEC DDR3 1.5V and LV-DDR3 1.35V /1.25V SDRAM (not verified) specifications • PCIe® Technology • Integrated Memory Controller • Integrated Graphics AMD Radeon™ HD 7000G Series graphics. • Dedicated graphics memory controller • 2D Acceleration Features • Open GL 4.2 & 2.0 • DirectX® 11 compliant 3D Acceleration Features • Adaptive Anti Aliasing, Shader Model 5 • Motion Video Acceleration Features • Dedicated hardware (UVD 3) for H.264 • VC-1, DivX and MPEG2 decode • HDCP (High-bandwidth Digital Content Protection) supported on DisplayPort Interface. • Display Port 1.2 and DVI/HDMI support via passive adapter.
Companion Device	<p>AMD A70M Hudson-M3 Controller Hub</p> <ul style="list-style-type: none"> • Unified Media Interface (UMI) (5.0 GT/s) • PCI Express® 2.0 Controller • PCI Host Bus Controller • USB Controllers with up to 14 USB ports • SMBus Controller • SATA Controller with RAID 0,1,10 support • High Definition Audio • Real Time Clock (RTC) • Integrated Clock controller • ACPI 3.0 compliant

Memory	<p>Memory controller is integrated in the AMD eTrinity FP2 processor.</p> <p>Features are:</p> <ul style="list-style-type: none"> Compliant with JEDEC DDR3 1.5V and LV-DDR3 1.35V / 1.25 SDRAM (not verified) specifications Supports DDR3 SODIMM 204pin single ranks up to 4GB DRAM technology DDR3 1066/1333MT/s (PC3-8500/PC3-10600) From 1GB to 2x 8GB maximum (16GB in total) <p>Notes: Less than 4GB displayed in System Properties using 32bit OS (Shared Video Memory/PCI resources is subtracted) ECC not supported</p>
Flash (BIOS)	32Mbit SPI Flash for dual System BIOS.
Security	<p>Intel® Integrated TPM 1.2 support</p> <p>Infineon TPM SLB9635TT1.2 (FW 3.17)</p>
IT8516E Embedded Controller	<p>KT Feature Connector.</p> <p>15 Multiplexed (GPIO, DAC, ADC, PWM & TIMER)</p> <p>Possible 152 GPIO expansion.</p> <p>Software Watchdog.</p>
Audio Codec	Audio, 7.1 Channel High Definition Audio Codec using the VIA VT1708S codec
Serial ATA	<p>5x SATA port J9 – J13, SATA 3.0</p> <p>1x mSATA J39 (mechanically sharing space with mPCIe slot J38), SATA 3.0</p> <ul style="list-style-type: none"> RAID Support (RAID modes 0 and 1)
Frontpanel	2xUSB, HDD-LED, SYSRST#, SUSLED, PWRBTN#, AUDIO Line/MIC output.
PCIe	<p>1x PCI Express x8 Slot (in mechanically x16 slot)</p> <p>1x PCI Express x4 Slot (in mechanically x16 slot)</p> <p>1x mPCIe Slot J38 (mechanically sharing space with mSATA slot J39)</p>
DisplayPort	<p>3x DisplayPort connector (in REAR-IO area)</p> <p>DP1 J43</p> <p>DP2 J3</p> <p>DPO J4</p> <p>Optionally Add-On card with 1x DisplayPort</p>
LVDS	Optionally Add-On card (TBD)
Audio Jack	<p>3x Audiojacks stack J40 (in REAR-IO area)</p> <p>Blue Line-In</p> <p>Green Speaker</p> <p>Pink Mic</p>
Audio	<p>Audio Pin header J41</p> <p>Line-out</p> <p>Line-in</p> <p>Surround output: SIDE, LFE, CEN, BACK and FRONT</p> <p>Microphone: MIC1 and MIC2</p> <p>CDROM in</p> <p>SPDIF (electrical Interface only)</p>

LAN	<p>Two RJ45 connectors J8 (in REAR-IO area)</p> <ul style="list-style-type: none"> • 2x 10/100/1000Mbps/s LAN (ETH1/ETH2) using Intel® Pearsonville xGB PCI Express Ethernet controller (WGI211ATSLJXZ). • PXE Netboot supported. • Wake On LAN (WOL) supported
USB	<p>13x USB ports (9x USB2.0 & 4x USB2.0/USB3.0):</p> <p>2x USB2.0 in Frontpanel Connector J5</p> <p>2x USB2.0 in USB Internal USB Connector J16</p> <p>4x USB2.0, USB stack J20 (in REAR-IO area)</p> <p>2x USB 2.0/USB3.0, Right USB stack J14 (in REAR-IO area)</p> <p>2x USB 2.0/USB3.0, left USB stack J15 (in REAR-IO area)</p> <p>1x USB 2.0 in mPCIe socket J38</p>
Serial port	<p>2x RS232 pin header (+12V, -12V supply generated by driver circuit)</p> <p>COM1 2x 5 Pin row J23</p> <p>COM2 2x 5 Pin row J22</p>
LPC	LPC connector J29
FAN	<p>CPUFAN 4 pin row J25 12V PWM</p> <p>SYSFAN 4 pin row J24 12V PWM</p>
PS2 Kbd/Mse	1x 6 Pin row Keyboard / Mouse PS2 cable kit interface J27
Power Plug	<p>1x 4 pole External connector J28 (in REAR-IO area)</p> <p>1x 4 pole Internal connector J19</p> <p>(+12V Single Supply , Max 260W)</p> <p>1x 2 pole Internal 12V Standby power input J31</p> <p>1x 4 pin row Power Out 12V (4 Amp max.) and 5V (3 Amp max.) J18</p>
Battery	<p>Exchangeable 3.0V Lithium battery for on-board Real Time Clock and CMOS RAM.</p> <p>Manufacturer Panasonic / Part-number CR-2032L/BN, CR2032N/BN or CR-2032L/BE.</p> <p>Approximate 6 years retention.</p> <p>Current draw is 4 μA when PSU is disconnected and 0 μA in S0 – S5.</p> <p>CAUTION: Danger of explosion if the battery is incorrectly replaced. Replace only with the same or equivalent type recommended by the manufacturer. Dispose of used batteries according to the manufacturer's instructions.</p>
Speaker	<p>On-board Speaker Piezo</p> <p>On-board speaker (Electromagnetic Sound Generator like Hycom HY-05LF)</p>

Environmental	<p>Operating: 0°C – 60°C operating temperature (forced cooling). It is the customer’s responsibility to provide sufficient airflow around each of the components to keep them within allowed temperature range.</p> <p>10% - 90% relative humidity (non-condensing)</p> <p>Storage: -20°C – 70°C; lower limit of storage temperature is defined by specification restriction of on-board CR2032 battery. Board with battery has been verified for storage temperature down to -40°C by Kontron.</p> <p>5% - 95% relative humidity (non-condensing)</p> <p>Electro Static Discharge (ESD) / Radiated Emissions (EMI): All Peripheral interfaces intended for connection to external equipment are ESD/ EMI protected. EN 61000-4-2:2000 ESD Immunity EN55022:1998 class B Generic Emission Standard.</p> <p>Safety: EN 60950-1: 2006/ A11:2009/ A1:2010/A12:2011 IEC 60950-1(ed.2) CSA C22.2 No. 60950-1 Product Category: Information Technology Equipment Including Electrical Business Equipment Product Category CCN: NWGQ2, NWGQ8 File number: E194252 (E194252-A21-CB-1)</p> <p>Theoretical MTBF: 327.518 / 162.430 hours @ 40°C / 60°C</p> <p>Restriction of Hazardous Substances (RoHS): All boards in the KTA70M family are RoHS/RoHS-II compliant.</p> <p>Capacitor utilization: No Tantalum capacitors on board Only Japanese brand Solid capacitors rated for 100 °C used on board</p>
BIOS	<p>AMI EFI SPI Connector J21 (for BIOS Recovery) Clear CMOS J34 Always On J37</p>
OS (planned)	<p>Windows 7 (32 and 64bit) Windows 8 (32 and 64bit) Windows XP (32 bit) DOS Windows Embedded 7</p>

3.2 KTA70M/mITX Block Diagram

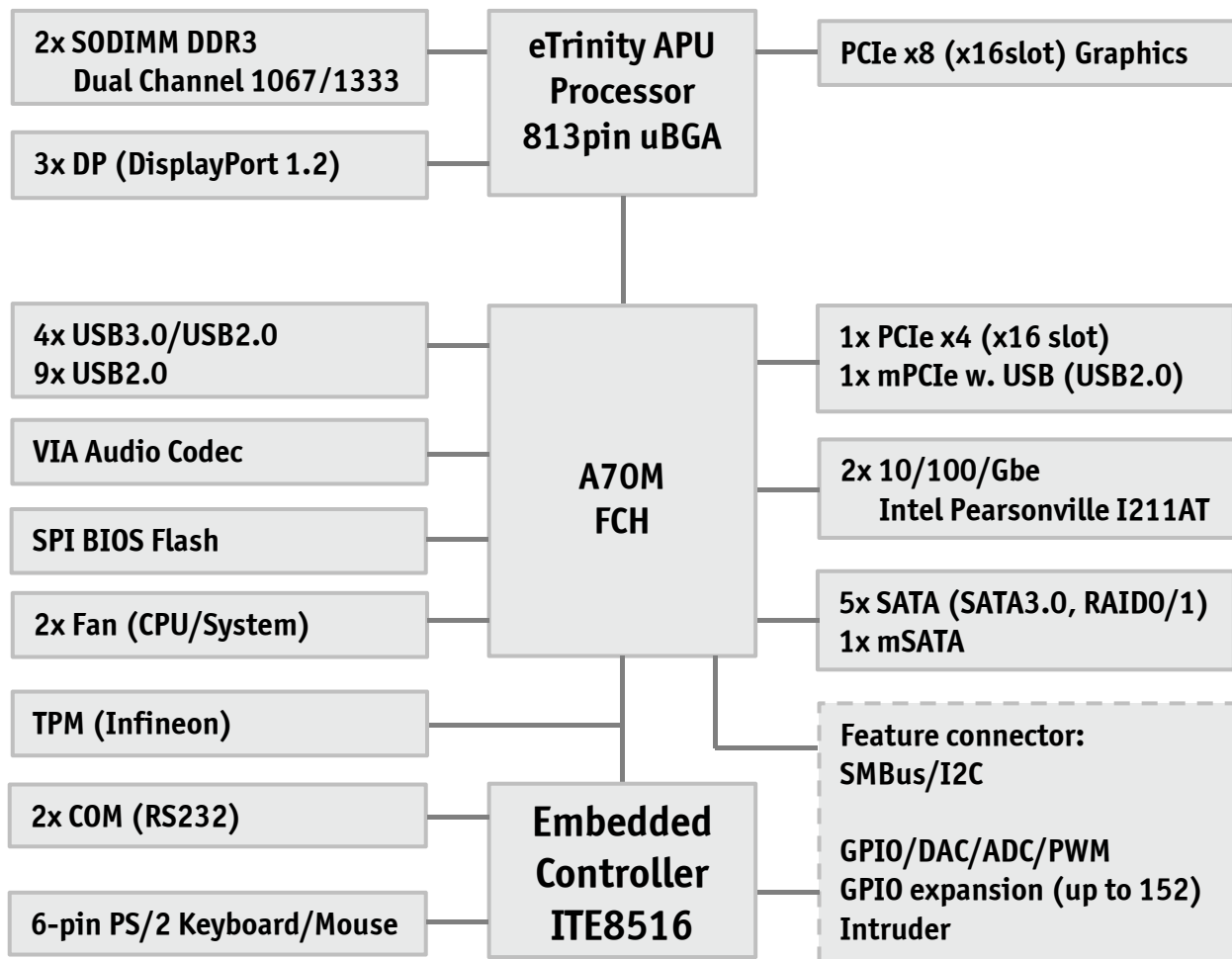

3.3 Power Consumption

Total System power example

Operation	Power Supplied
Windows 7 32bit Idle	840mA
Windows 7 32bit 3Dmark 2005	1680mA
Windows 7 32bit Burn In Test v6	1740mA

More detailed Static Power Consumption

On the following pages the power consumption of the KTA70M mITX Board is measured under:

- 1- DOS, idle, mean
- 2- Windows7, Running 3DMARK 2005 & BurnInTest v6, mean
- 3- S1, mean
- 4- S3, mean
- 5- S4, mean

The following items were used in the test setup:

1. Low Power Setup:

Standard system configuration equipped with AMD dual-core 2.1GHz CPU, 1xPCIe card, internal graphics, 2x SATA disks, 1x SODIMM (1GB Module), Monitor, USB Keyboard & Mouse, 1x 8GB USB Stick.

High Power Setup:

Standard system configuration equipped with AMD dual-core 2.1GHz CPU, PCIex4, PCIex8, miniPCIe WLAN, 4x SATA disks, 1x DIMM (4GB Modules), Monitor, Display Port or HDMI Monitor, USB Keyboard & Mouse. 4x 4-8GB USB Sticks

2. 12V active cooler
3. USB Keyboard/Mouse
4. Monitor
5. 3.5" HDD WD WD1600AA
6. ATX Fortron 400W
7. Tektronix TDS5104B
8. Tektronix TCPA300
9. Tektronix TCP312
10. Fluke 289

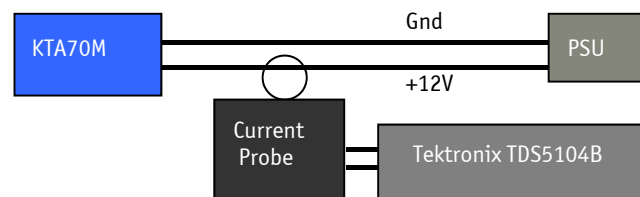

Note: The Power consumption of Monitor and HDDs is not included.

Warning: Hot Plugging power supply is not supported. Hot plugging might damage the board.

Low Power Setup results:

DOS Idle, Mean, No external load	Current draw	Power consumption
	1650mA	19.80W

Windows 7, mean 3DMARK2005 (first scene) & CPUBURN	Current draw	Power consumption
	2160mA	25.92W

S3 Mode, Mean, No external load	Current draw	Power consumption
	50mA	0.60W

S4 Mode, Mean, No external load	Current draw	Power consumption
	46mA	0.55W

High Power Setup results:

DOS Idle, Mean, No external load	Current draw	Power consumption
	2017mA	24.20W

Windows 7, mean 3DMARK2005 (first scene) & CPUBURN	Current draw	Power consumption
	2534mA	30.41W

S3 Mode, Mean, No external load	Current draw	Power consumption
	77mA	0.93W

S4 Mode, Mean, No external load	Current draw	Power consumption
	55mA	0.66W

3.4 USB ports overview

The KTA70M board contains two pairs of EHCI (Enhanced Host Controller Interface) and OHCI (Open Host Controller Interface) in order to support up to 9 USB1.1/USB2.0 devices and further more two xHCI (Extensible Host Controller Interface) to support up to 4 USB3.0 devices.

The OHCI controllers support USB1.1, Full-Speed (12Mbps) and Low-Speed (1.5Mbps).

The EHCI controllers support USB2.0, High-Speed (480Mbps).

The xHCI controllers support USB3.0, USB2.0 and USB 1.1, Super-Speed (5.0Gbps), High-Speed (480Mbps), Full-Speed (12Mbps) and Low-Speed (1.5Mbps)

Legacy Keyboard/Mouse and wakeup from sleep states are supported. Over-current detection on all USB ports except USB2.

USB #	USB standard	Connector location	HCI	Note
USB0 USB1	USB2.0 /USB1.1	Frontpanel (J5)	OHCI1/EHCI1	
USB2	USB2.0 /USB1.1	mPCIe (J38)	OHCI1/EHCI1	No over current detection
USB3	USB2.0 /USB1.1	-	-	USB3 doesn't exist
USB4	USB2.0 /USB1.1	Pin row (J16)	OHCI1/EHCI1	
USB5	USB2.0 /USB1.1	Pin row (J16)	OHCI2/EHCI2	
USB6 USB7 USB8 USB9	USB2.0 /USB1.1	USB quad stack (J20) Rear IO	OHCI2/EHCI2	
USB10 USB11	USB3.0/USB2.0/USB1.1	USB3.0 dual stack (J15) Left - Rear IO	xHCI1	
USB12 USB13	USB3.0/USB2.0/USB1.1	USB3.0 dual stack (J14) Right - Rear IO	xHCI2	

Notes: *In order to meet the requirements of USB standard, the 5V input supply must be at least 5.00V.*

The contacts for USB devices are protected and suitable to supply USB devices with a maximum input current of 1000mA.

Do not supply external USB devices with higher power dissipation through these pins To protect the external power lines of peripheral devices make sure that

- the wires have the right diameter to withstand the maximum available current.*
- to enclosure of the peripheral device fulfills the fire-protecting conditions of IEC/EN 60950.*

For USB2.0 cabling it is required to use only HiSpeed USB cable, specified in USB2.0 standard:

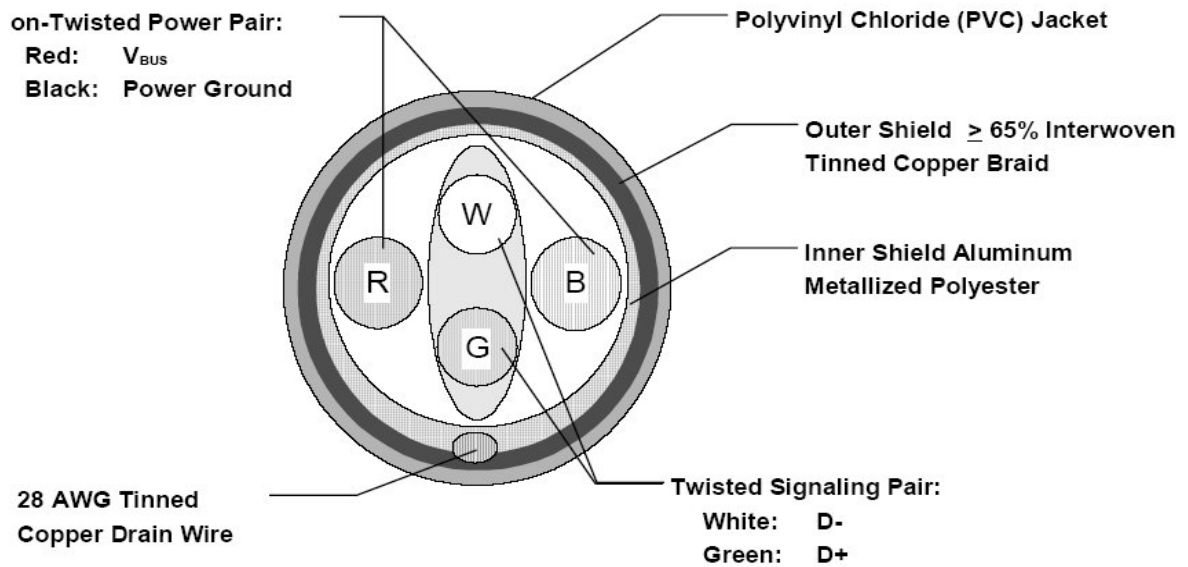

For USB3.0 cabling it is required to use only HiSpeed USB cable, specified in USB3.0 standard:

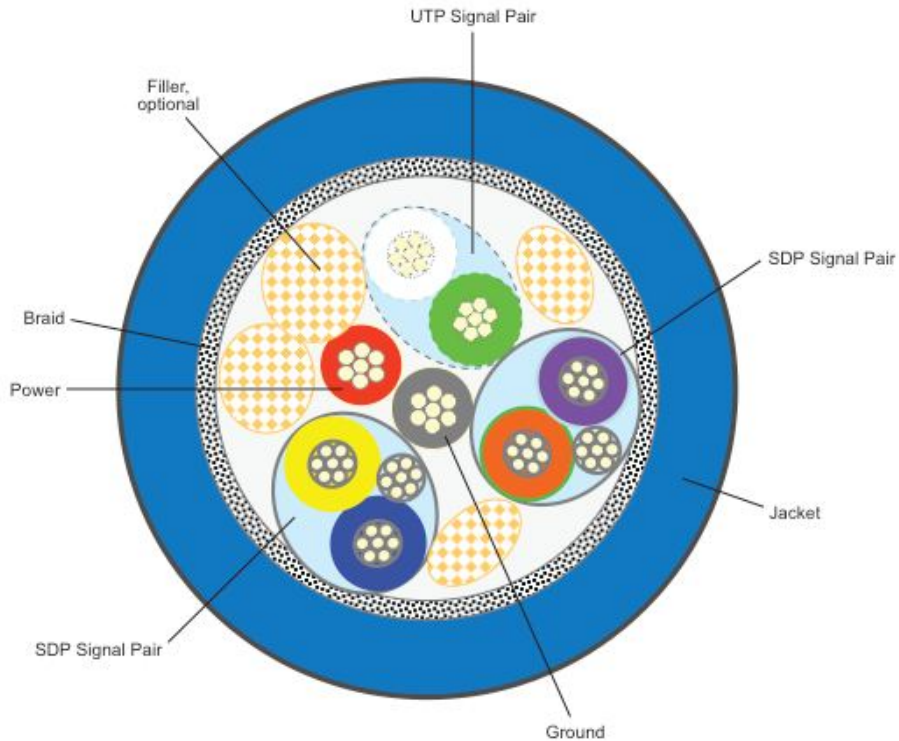

4 Connectors Locations

4.1 KTA70m/mITX Topview

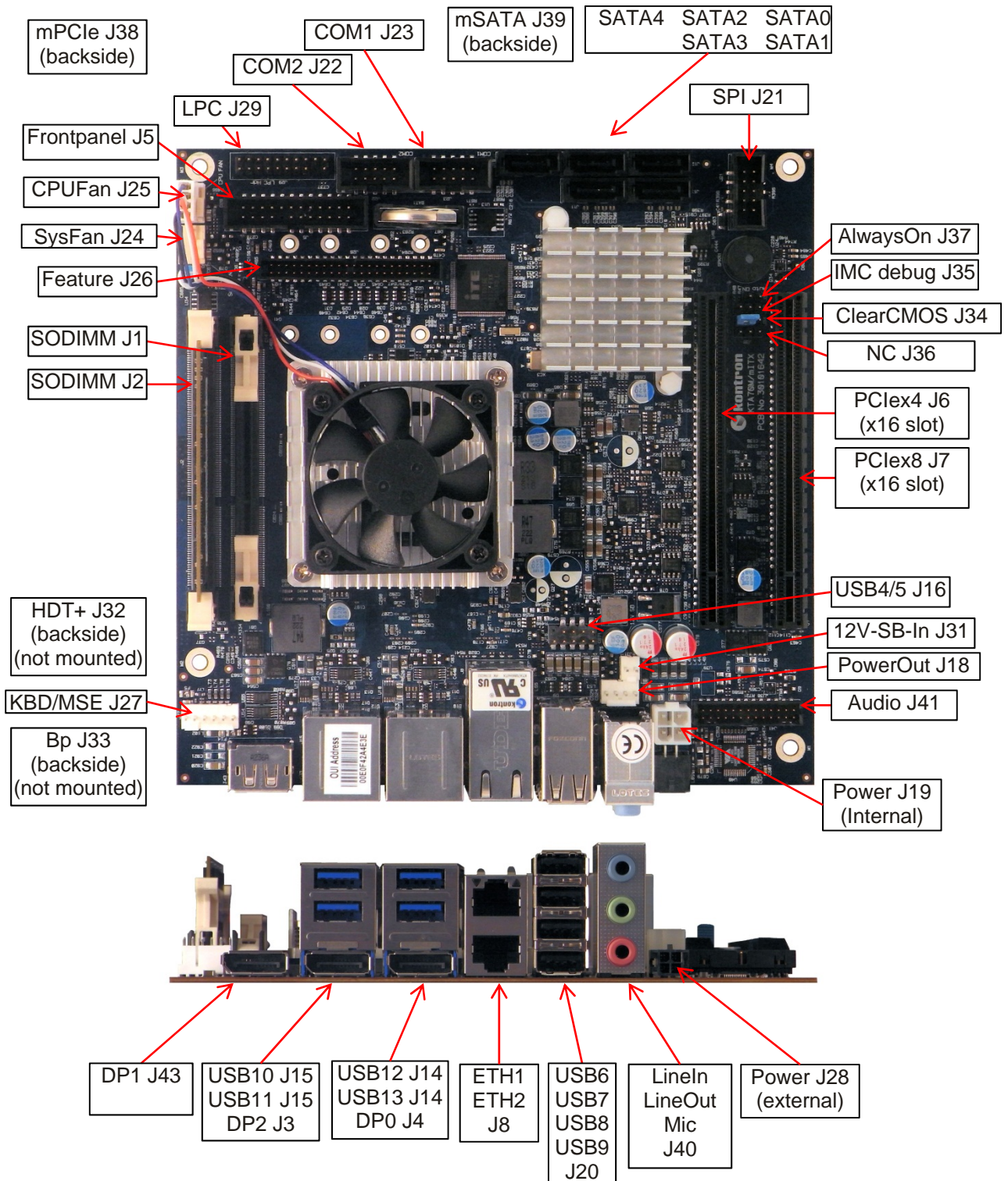

4.2 KTA70m/mITX Bottomview

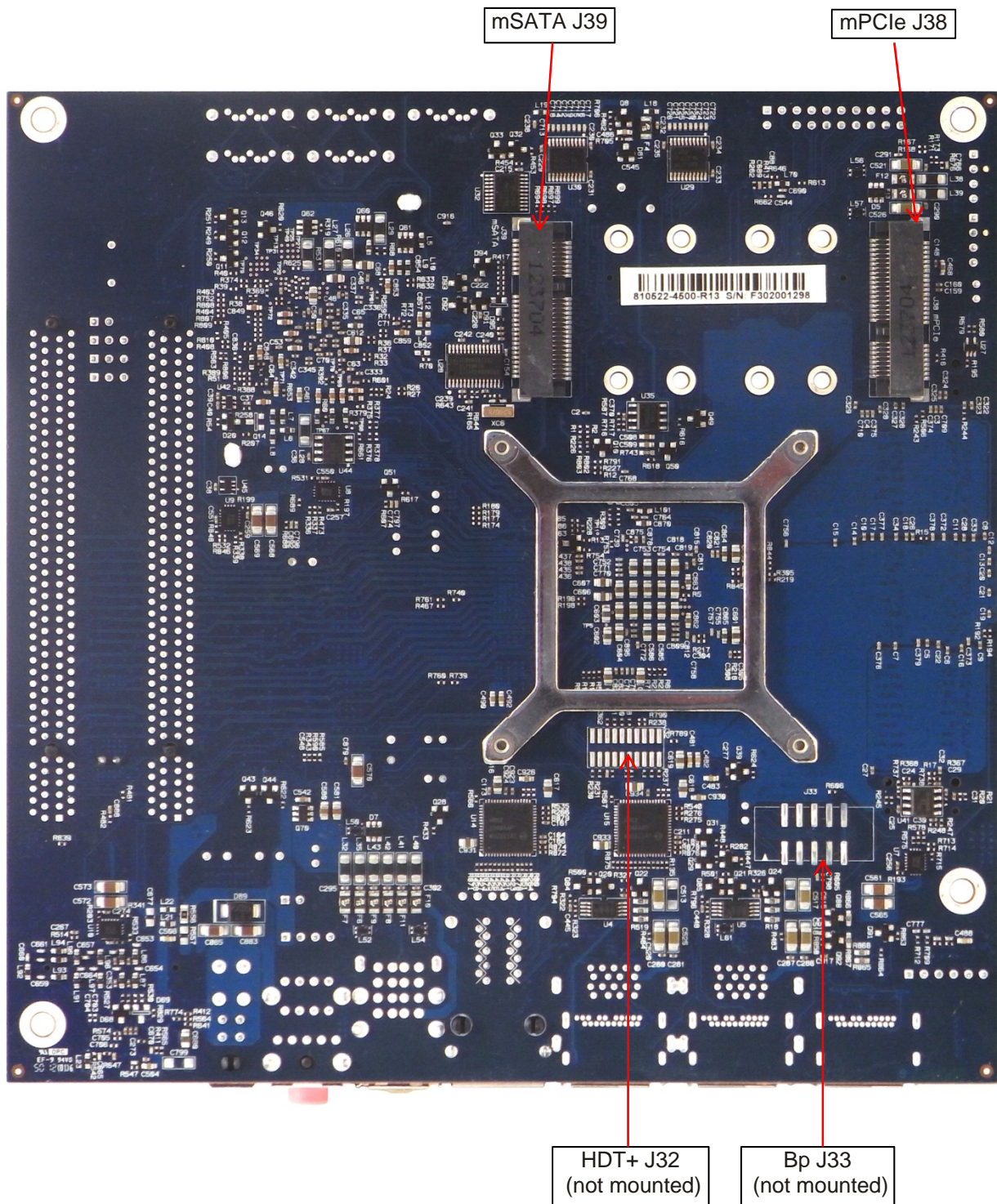

5 Connector Signal Definitions

The following sections provide pin definitions and detailed description of all onboard connectors. The connector definitions follow the following notation:

Column Name	Description
Pin	Shows the pin numbers in the connector.
Signal	The mnemonic name of the signal at the current pin. The notation “#” states that the signal is active low.
Type	AI: <u>A</u> nalogue <u>I</u> nput AO: <u>A</u> nalogue <u>O</u> utput I: <u>D</u> igital <u>I</u> nput IO: <u>D</u> igital <u>I</u> nput / <u>O</u> utput IOD: <u>I</u> nput / <u>O</u> pen <u>D</u> rain output O: <u>D</u> igital <u>O</u> utput DSO: <u>D</u> ifferential <u>S</u> ignaling <u>O</u> utput with complementary signals on two paired wires DSI: <u>D</u> ifferential <u>S</u> ignaling <u>I</u> nput with complementary signals on two paired wires DSIO: <u>D</u> ifferential <u>S</u> ignaling <u>I</u> nput / <u>O</u> utput (combined DSO and DSI) PWR: <u>P</u> o <u>W</u> e <u>R</u> supply or ground reference pins NC: Pin <u>N</u> ot <u>C</u> onnected <u>Additional notations:</u> -5.0 +5.0V signal voltage level, e.g. I-5.0 -3.3 +3.3V signal voltage level, e.g. O-3.3 -1.8 +1.8V signal voltage level, e.g. IO-1.8
Ioh/Iol	Ioh: Typical current in mA flowing out of an output pin through a grounded load while the output voltage has high level. Iol: Typical current in mA flowing into an output pin from a VCC connected load while the output voltage has low level.

The abbreviation tbd is used for specifications which are not available yet or which are not sufficiently specified by the component vendors.

6 Rear IO Connectors

6.1 DisplayPort (DPO/DP1/DP2) (J4/J43/J3)

The DP (DisplayPort) connectors are based on standard DP type Foxconn 3VD11203-H7AB-4H or similar.

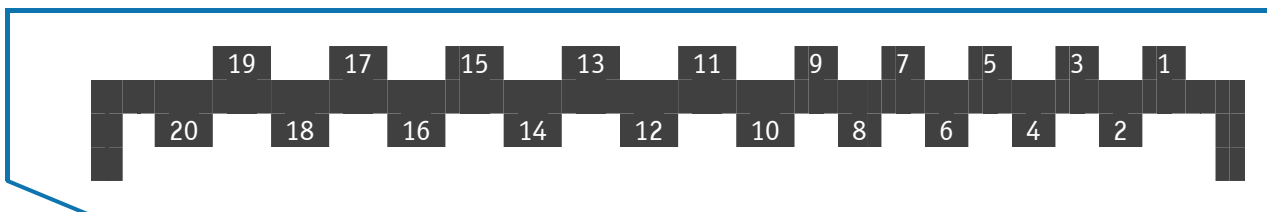

Pin	Signal	Description	Type	Note
1	Lane 0 (p)		LVDS	
2	GND		PWR	
3	Lane 0 (n)		LVDS	
4	Lane 1 (p)		LVDS	
5	GND		PWR	
6	Lane 1 (n)		LVDS	
7	Lane 2 (p)		LVDS	
8	GND		PWR	
9	Lane 2 (n)		LVDS	
10	Lane 3 (p)		LVDS	
11	GND		PWR	
12	Lane 3 (n)		LVDS	
13	Config1	Aux or DDC selection	I	Internally pull down (1Mohm). Aux channel on pin 15/17 selected as default (when NC) DDC channel on pin 15/17, If HDMI adapter used (3.3V)
14	Config2	(Not used)	0	Internally connected to GND
15	Aux Ch (p)	Aux Channel (+) or DDC Clk		AUX (+) channel used by DP DDC Clk used by HDMI
16	GND		PWR	
17	Aux Ch (n)	Aux Channel (-) or DDC Data		AUX (-) channel used by DP DDC Data used by HDMI
18	Hot Plug		I	Internally pull down (100Kohm).
19	Return		PWR	Same as GND
20	3.3V		PWR	Fused by 1.5A resetable PTC fuse, common for DPO and DP1

Note: *To protect the external power lines of peripheral devices make sure that*

- *the wires have the right diameter to withstand the maximum available current.*
- *to enclosure of the peripheral device fulfills the fire-protecting conditions of IEC/EN 60950.*

The 3 DisplayPorts (DP0, DP1 and DP2) can be used in a 3 independent display configuration. By use of DP Adapter Converters it is possible to implement a mix of DP, VGA, HDMI and DVI-D outputs and still support 3 independent displays configuration.

Available DP adapters:



DP to VGA
PN 1045-5779

DP to HDMI
PN 1045-5781

DP to DVI-D
PN 1045-5780

DP Extention Cable:



In order to prevent mechanical conflicts the above DP adapters can be connected to DP#0, DP#1 and DP#2 via the 1051-7619 Cable DP Extender cable 200mm.

The DP to VGA adapter is an “active” converter, meaning that seen from the graphics controller it looks like a DP. The HDMI and DVI converters are passive converters, meaning that they inform the graphics controller about its type and the graphics controller then replace the DP signals with TMDS signals (used in HDMI and DVI).

The HDMI interface supports the HDMI 1.4a specification including audio codec. Limitations to the resolution apply: 2048x1536 (VGA), 1920x1200 (HDMI and DVI).

Four independent (simultaneously) displays (without using PCIe Graphics cards) is a possible configuration under the following conditions:

1. A DP-PCIe passive card or DP-DVI passive card must be used in the outermost PCIe slot.
2. All DP must be converted to DVI-D or HDMI via passive adapters like above adapters.
3. Two of the panels must have the same timing (as if two panels are of the exact same type).

6.2 USB3.0 Connectors (USB10/USB11/USB12/USB13) (J15/J15/J14/J14)

The USB3.0 connectors are based on standard USB3.0 connectors type Lotes ABA-USB-104-K01 or similar.

These 4 USB3.0 ports are controlled by the xHCI controllers supporting USB3.0, USB2.0 and USB 1.1, Super-Speed (5.0Gbps), High-Speed (480Mbps), Full-Speed (12Mbps) and Low-Speed (1.5Mbps)

USB Ports 10 and 11 (mounted on top of the DP#2 port):

Note	Type	Signal	PIN				Signal	Type	Note
	DSIO-3.3		USB10-		USB10+			DSIO-3.3	
1	PWR	5V/SB5V	1	2	3	4	GND	PWR	
	DSIO-3.3	RX10-	5	6	7	8	9	TX10+	DSIO-3.3
	DSIO-3.3		RX10+		TX10-			DSIO-3.3	
	PWR		GND						
	DSIO-3.3		USB11-		USB11+			DSIO-3.3	
1	PWR	5V/SB5V	1	2	3	4	GND	PWR	
	DSIO-3.3	RX11-	5	6	7	8	9	TX11+	DSIO-3.3
	DSIO-3.3		RX11+		TX11-			DSIO-3.3	
	PWR		GND						

Signal	Description
USB10+ USB10- RX10+ RX10- TX10+ TX10- USB11+ USB11- RX11+ RX11- TX11+ TX11-	Differential pair works as Data/Address/Command Bus.
5V/SB5V	5V supply for external device. SB5V is supplied during powerdown to allow wakeup on device activity. Protected by current limited power distribution switch, 1A for each port.

USB Ports 12 and 13 (mounted on top of the DP#0 port):

Note	Type	Signal	PIN				Signal	Type	Note
	DSIO-3.3		USB12-		USB12+			DSIO-3.3	
1	PWR	5V/SB5V	1	2	3	4	GND	PWR	
	DSIO-3.3	RX12-	5	6	7	8	9	TX12+	DSIO-3.3
	DSIO-3.3		RX12+		TX12-			DSIO-3.3	
	PWR		GND						
	DSIO-3.3		USB13-		USB13+			DSIO-3.3	
1	PWR	5V/SB5V	1	2	3	4	GND	PWR	
	DSIO-3.3	RX13-	5	6	7	8	9	TX13+	DSIO-3.3
	IO		RX13+		TX13-			DSIO-3.3	
	PWR		GND						

Signal	Description
USB12+ USB12- RX12+ RX12- TX12+ TX12- USB13+ USB13- RX13+ RX13- TX13+ TX13-	Differential pair works as Data/Address/Command Bus.
5V/SB5V	5V supply for external device. SB5V is supplied during powerdown to allow wakeup on device activity. Protected by current limited power distribution switch, 1A for each port.

Notes: *In order to meet the requirements of USB standard, the 5V input supply must be at least 5.00V.*

The contacts for USB devices are protected and suitable to supply USB devices with a maximum input current of 1000mA.

Do not supply external USB devices with higher power dissipation through these pins. To protect the external power lines of peripheral devices make sure that

- the wires have the right diameter to withstand the maximum available current.*
- to enclosure of the peripheral device fulfills the fire-protecting conditions of IEC/EN 60950.*

6.3 Ethernet Connectors (ETH1/ETH2) (J8)

The KTA70M supports two 10/100/1000Mb Ethernet RJ45 connectors in a stacked dual LAN connector, type Ude RMT-123AGF1F or similar. Both ports are driven by Intel® Pearsonville WGI211AT PCI Express controller.

Ethernet connector 1 (ETH1) is mounted above Ethernet connector 2 (ETH2).

Signal	PIN								Note	
LED1									LED Lights when ETH1 Link, Flashing when activity	
MDIO+										
MDIO-										
MDI1+										
MDI2+										
MDI2-										
MDI1-										
MDI3+										
MDI3-										
LED2									LED Lights when ETH2 Link, Flashing when activity	
ETH1		8	7	6	5	4	3	2	1	
ETH2		1	2	3	4	5	6	7	8	
MDIO+										
MDIO-										
MDI1+										
MDI2+										
MDI2-										
MDI1-										
MDI3+										
MDI3-										

In order to achieve the specified performance of the Ethernet port, Category 5 twisted pair cables must be used with 10/100MB and Category 5E, 6 or 6E with 1Gb LAN networks.

Signal	Description
MDI[0]+ / MDI[0]-	MDI mode: first pair in 1000Base-T (i.e. the BI_DA+/- pair), transmit pair in 10/100Base-T. MDI crossover mode: acts as the BI_DB+/- pair, receive pair in 10/100Base-TX.
MDI[1]+ / MDI[1]-	MDI mode: second pair in 1000Base-T (i.e. the BI_DB+/- pair), receive pair in 10/100Base-T. MDI crossover mode: acts as the BI_DA+/- pair, transmit pair in 10/100Base-T.
MDI[2]+ / MDI[2]-	MDI mode: third pair in 1000Base-T (i.e. the BI_DC+/- pair). MDI crossover mode: acts as the BI_DD+/- pair.
MDI[3]+ / MDI[3]-	MDI mode: fourth pair in 1000Base-T (i.e. the BI_DD+/- pair). MDI crossover mode: acts as the BI_DC+/- pair.

Note: MDI = Media Dependent Interface.

6.4 USB x4 Stack Connector (USB6/USB7/USB8/USB9) (J20)

USB Ports 6, 7, 8 and 9 are mounted in a single stack in the IO Area type Foxconn UB11123-Q8DF-4F or similar. The USB ports are controlled by a single set of OHCI and EHCI controllers (also shared by USB5).

The OHCI controllers support USB1.1, Full-Speed (12Mbps) and Low-Speed (1.5Mbps).
The EHCI controllers support USB2.0, High-Speed (480Mbps).

Note	Type	Signal	PIN				Signal	Type	Note
	PWR	5V/SB5V	1	2	3	4	GND	PWR	
	DSIO-3.3	USB6-					USB6+	DSIO-3.3	
	PWR	5V/SB5V	1	2	3	4	GND	PWR	
	DSIO-3.3	USB7-					USB7+	DSIO-3.3	
	PWR	5V/SB5V	1	2	3	4	GND	PWR	
	DSIO-3.3	USB8-					USB8+	DSIO-3.3	
	PWR	5V/SB5V	1	2	3	4	GND	PWR	
	DSIO-3.3	USB9-					USB9+	DSIO-3.3	

Signal	Description
USB6+ USB6- USB7+ USB7- USB8+ USB8- USB9+ USB9-	Differential pair works as Data/Address/Command Bus.
5V/SB5V	5V supply for external devices. SB5V is supplied during powerdown to allow wakeup on USB device activity. Protected by individual resettable 1A fuse.

Notes: *In order to meet the requirements of USB standard, the 5V input supply must be at least 5.00V.*

The contacts for USB devices are protected and suitable to supply USB devices with a maximum input current of 1000mA.

Do not supply external USB devices with higher power dissipation through these pins. To protect the external power lines of peripheral devices make sure that

- the wires have the right diameter to withstand the maximum available current.*
- to enclosure of the peripheral device fulfills the fire-protecting conditions of IEC/EN 60950.*

6.5 Audio Interface (J40)

The on-board Audio circuit, based on Via VT1708S, implements 7.1+2 Channel High Definition Audio with UAA (Universal Audio Architecture), featuring five 24-bit stereo DACs and three 20-bit stereo ADCs. The following Audio connector is available in IO Area.

Audio Speakers, Line-in and Microphone are available in the stacked audiojack connector type Lotes ABA-JAK-028-K03

	Signal	Type	Note
TIP	LINE1-L	IA	
RING	LINE1-R	IA	
SLEEVE	GND	PWR	
TIP	FRONT-OUT-L	OA	
RING	FRONT-OUT-R	OA	
SLEEVE	GND	PWR	
TIP	MIC1-L	IA	
RING	MIC1-R	IA	
SLEEVE	GND	PWR	

Signal	Description	Note
FRONT-OUT-L	Front Speakers (Speaker Out Left).	
FRONT-OUT-R	Front Speakers (Speaker Out Right).	
MIC1-L	Microphone 1 - Left	Shared with Audio Header
MIC1-R	Microphone 1 - Right	Shared with Audio Header
LINE1-L	Line 1 signal - Left	Shared with Audio Header
LINE1-R	Line 1 signal - Right	Shared with Audio Header

6.6 DC Power External Connector (J28)

The KTA70M/mITX board has an external power input connector for supplying voltage in the range from +11.4V to +12.6V. The power connector is a 4 pin Micro-Fit type Molex 0430450402 or similar.

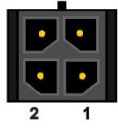
Header	Pin	Signal	Description
	1	12V	Power supply +12V
	2	12V	Power supply +12V
	3	GND	Ground
	4	GND	Ground

Warning: Hot Plugging power supply is not supported. Hot plugging might damage the board.

Notes: **To protect the external power lines of peripheral devices make sure that**

- the wires have the right diameter to withstand the maximum available current.
- to enclosure of the peripheral device fulfills the fire-protecting conditions of IEC/EN 60950.

Alternatively the DC Power Internal Connector can be used

Available cable kit:



PN 1052-5814 Cable ATX Power for KTA70M, 200mm long.

7 Pin Connectors

7.1 DC Power Internal Connector (J19)

The KTA70M/mITX has an internal power input connector for supplying voltage in the range from +11.4V to +12.6V. The power connector is a 4 pin 12V ATX connector type Lotes ABA-POW-003-K02 or similar.

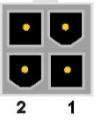
Header	Pin	Signal	Description
	1	GND	Ground
	2	GND	Ground
	3	12V	Power supply +12V
	4	12V	Power supply +12V

Warning: Hot Plugging power supply is not supported. Hot plugging might damage the board.

Notes: *To protect the external power lines of peripheral devices make sure that*

- the wires have the right diameter to withstand the maximum available current.
- to enclosure of the peripheral device fulfills the fire-protecting conditions of IEC/EN 60950.

Alternatively the DC Power External Connector can be used

7.1 12V-SB-In Connector (J31)

The 12V-SB-In (12V StandBy power Input) connector is a 2 pin connector type Molex 22-23-2021 or similar. This connector can be used to add 12V Standby Power for use when 12V is not present on DC Power Internal or DC Power External connectors.

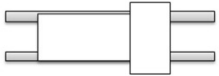
Header	Pin	Signal	Description	Type
	1	12V	Power +12V	PWR
	2	GND	Ground	PWR

The 12V (connected to pin 1) is connected to the 12V power rail via a diode to prevent reverse powering. Maximum allowed supplied current is 1A, so power limitation feature must be built in the power circuit connected to the 12V-SB-In connector.

Notes: *To protect the external power lines of peripheral devices make sure that*

- the wires have the right diameter to withstand the maximum available current.
- to enclosure of the peripheral device fulfills the fire-protecting conditions of IEC/EN 60950.

7.2 Audio Header Connector (J41)

The Audio Header connector is a 26 pin connector type Molex 87832-2620 or similar.

Note	Type	Signal	PIN	Signal	Type	Note
	AO	LFE-OUT	1 2	CEN-OUT	AO	
	PWR	AAGND	3 4	AAGND	PWR	
1	AO	FRONT-OUT-L	5 6	FRONT-OUT-R	AO	1
	PWR	AAGND	7 8	AAGND	PWR	
	AO	REAR-OUT-L	9 10	REAR-OUT-R	AO	
	AO	SIDE-OUT-L	11 12	SIDE-OUT-R	AO	
	PWR	AAGND	13 14	AAGND	PWR	
1	AI	MIC1-L	15 16	MIC1-R	AI	1
	PWR	AAGND	17 18	AAGND	PWR	
1		LINE1-L	19 20	LINE1-R		1
	NC	NC	21 22	AAGND	PWR	
	PWR	GND	23 24	NC	NC	
	O	SPDIF-OUT	25 26	GND	PWR	

Note 1: Shared with Audio Stack connector (in Rear IO area).

Signal	Description
FRONT-OUT-L	Front Speakers (Speaker Out Left).
FRONT-OUT-R	Front Speakers (Speaker Out Right).
REAR-OUT-L	Rear Speakers (Surround Out Left).
REAR-OUT-R	Rear Speakers (Surround Out Right).
SIDE-OUT-L	Side speakers (Surround Out Left)
SIDE-OUT-R	Side speakers (Surround Out Right)
CEN-OUT	Center Speaker (Center Out channel).
LFE-OUT	Subwoofer Speaker (Low Freq. Effect Out).
NC	No connection
MIC1	MIC Input 1
LINE1	Line 1 signals
F-SPDIF-OUT	S/PDIF Output
AAGND	Audio Analogue ground

Available cable kit:

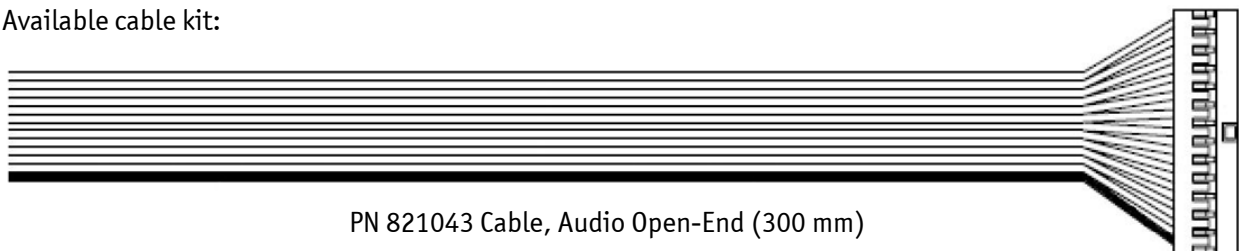

7.3 Power Out Connector (J18)

The Power Out connector can be used to power source external devices like HDD. The connector is type Molex 22-23-2041 or similar.

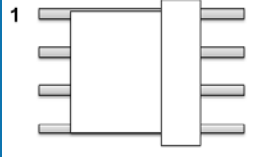
Header	Pin	Signal	Description	Type
	1	5V	Power +5V	PWR
	2	GND	Ground	PWR
	3	GND	Ground	PWR
	4	12V	Power +12V	PWR

Warning: Hot Plugging power supply is not supported. Hot plugging might damage the board.

Notes: To protect the external power lines of peripheral devices make sure that

- *the wires have the right diameter to withstand the maximum available current.*
- *to enclosure of the peripheral device fulfills the fire-protecting conditions of IEC/EN 60950.*

Available cable kit:

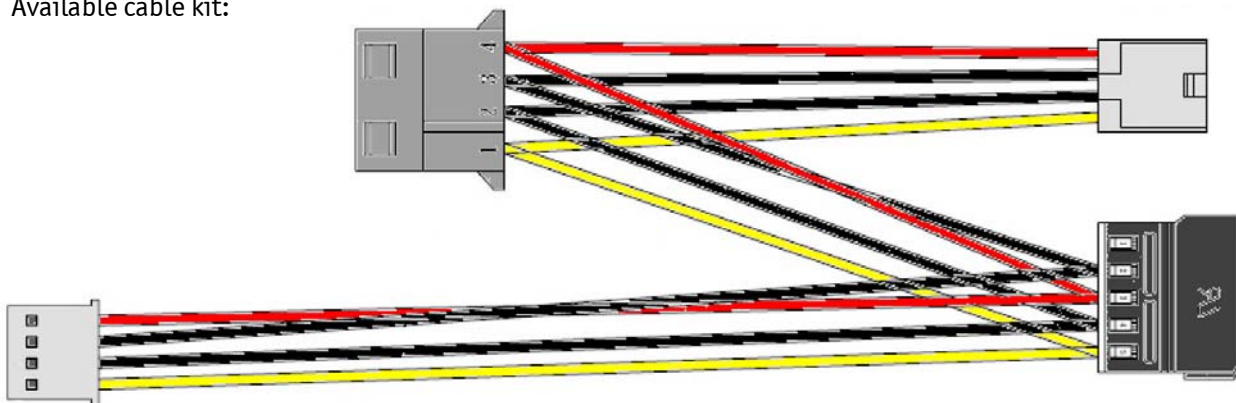

PN 1027-3669 Cable Power Out

7.4 USB4/5 Connector (J16)

USB Ports 4 and 5 are available via Pin Row connector type Foxconn HS1105F-RNP9 or similar.

The USB4 port is controlled by a set of OHCI and EHCI controllers (also shared by USB0/1/2).
The USB5 port is controlled by a set of OHCI and EHCI controllers (also shared by USB6/7/8/9).

The OHCI controllers support USB1.1, Full-Speed (12Mbps) and Low-Speed (1.5Mbps).
The EHCI controllers support USB2.0, High-Speed (480Mbps).

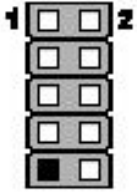
Header	Pin	Signal	Description	Type
	1	5V/SB5V	5V (always) protected by separate 1A resettable fuse	PWR
	2	5V/SB5V	5V (always) protected by separate 1A resettable fuse	PWR
	3	USB4-	Differential pair 4 -	DSIO-3.3
	4	USB5-	Differential pair 5 -	DSIO-3.3
	5	USB4+	Differential pair 4 +	DSIO-3.3
	6	USB4+	Differential pair 5 +	DSIO-3.3
	7	GND	Ground	PWR
	8	GND	Ground	PWR
	-		(pin not mounted -Used for keying)	
	10	KEY		NC

Notes: *In order to meet the requirements of USB standard, the 5V input supply must be at least 5.00V.*

The contacts for USB devices are protected and suitable to supply USB devices with a maximum input current of 1000mA.

Do not supply external USB devices with higher power dissipation through these pins To protect the external power lines of peripheral devices make sure that

- *the wires have the right diameter to withstand the maximum available current.*
- *to enclosure of the peripheral device fulfills the fire-protecting conditions of IEC/EN 60950.*



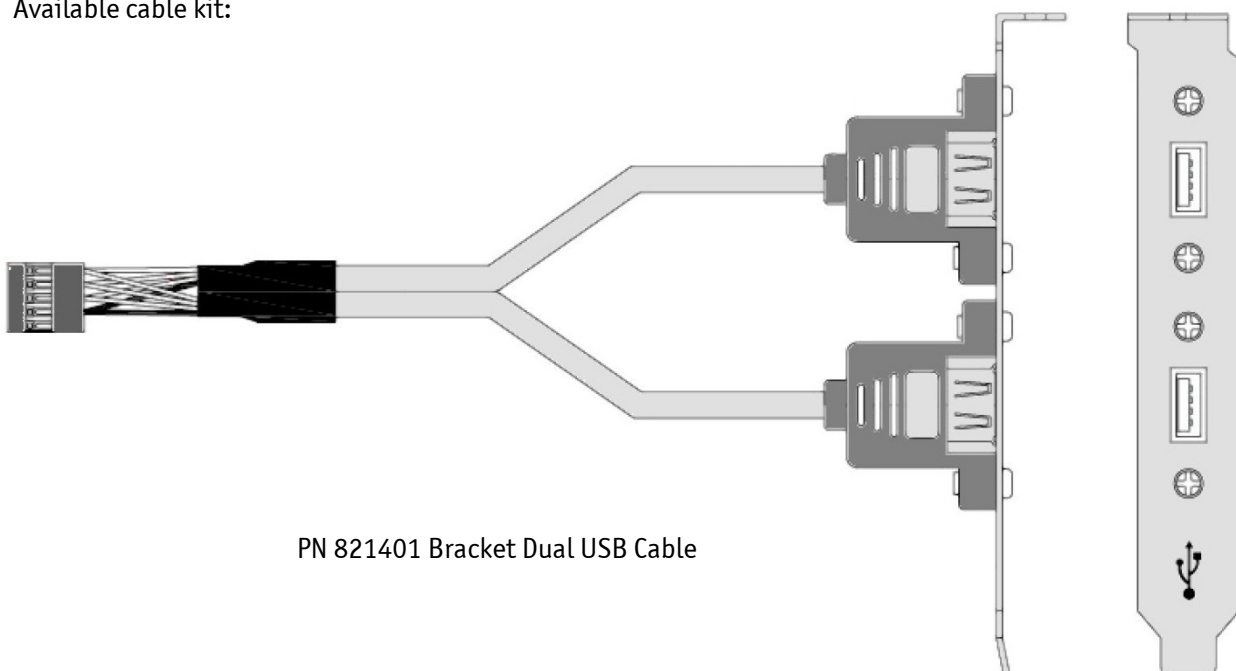

Available cable kit:



PN 821401 Bracket Dual USB Cable

7.5 Jumper area (J34, J35, J36, J37)

The KTA70M has a jumper area containing pin connectors 2.54mm pitch, for up to four jumpers, but normally only one jumper is used (jumper in the J34 pin 2-3 position, as indicated below).

Function	J#	Jumper in position 2-3	Pin			Jumper in position 1-2
			3	2	1	
Always On	J37	-				Always On
(none – connector not mounted)	J35	-				-
Clear CMOS	J34	Normal (Default)				Clear CMOS
Audio Short circuit test	J36	Front Left				Front Right

Always On: is PT not supported.

(None): Not mounted on final version of board. Only mounted on Early Field Test versions of KTA70M.

Clear CMOS: is used to erase all customised BIOS settings located in the CMOS RAM storage. If the board has a booting problem or is unstable, then Clearing CMOS by moving the Jumper from default position to the Clear CMOS position for approx. 10 sec. might solve the problem.



Warning

Don't leave the Clear CMOS jumper in position 1-2, otherwise if power is disconnected, the battery will fully deplete within a few weeks.

Audio Short Circuit Test: is only used in manufacturing test. No jumper should be installed.

7.6 SPI Connector (J21)

The KTA70 provides one synchronous full duplex SPI (Serial Peripheral Interface) Bus in a 10 pin header connector. The connector is type Pinrex 512-90-10GBE5 or similar.

Two things should be considered:

1. An onboard SPI™ flash coexists on the same interface lines. You must disable this component with a 3.3V power connection to the ADDIN signal (e.g. a short circuit jumper between pin 2 and 4).
2. The four SPI™ lines are protected with an additional bus driver and the ISOLATE# signal controls the output enable pin. For normal operation this signal should be high.

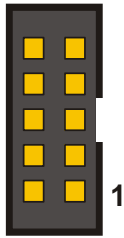
Header	Pin	Signal	Description	Type
	1	SPI_CLK	SPI clock	O-3.3
	2	3.3V	Power +3.3V	PWR
	3	SPI_CS#	SPI slave select, active low	O-3.3
	4	ADDIN	Disable onboard SPI flash	I-3.3
	5	RSVD	Reserved (10k pullup to 3.3V)	PWR
	6	N.C.	Not connected	NC
	7	SPI_MOSI	SPI master output, Slave Input	IO-3.3
	8	ISOLATE#	Disable the SPI interface	I-3.3
	9	SPI_MISO	SPI master input, Slave Output	IO-3.3
	10	GND	Ground	PWR

Signal	Further description
SB3V3	3.3V Standby Voltage power line. Normally output power, but when Motherboard is turned off then the on-board SPI Flash can be 3.3V power sourced via this pin.
ISOLATE#	The ISOLATE# input, active low, is normally NC, but must be connected to GND when loading SPI flash. Power Supply to the Motherboard must be turned off when loading SPI flash. The pull up resistor is connected via diode to 5VSB.

7.7 COM1/COM2 (J23/J22)

Two serial ports provide asynchronous serial communication via RS-232 interfaces. The connector is type Pinrex 512-90-10GBE5 or similar.

The pinout of Serial ports COM1 and COM2 is as follows:

Note	Ioh/Iol	Type	Signal	PIN		Signal	Type	Ioh/Iol	Note
	-	I	DCD	1	2	DSR	I	-	
	-	I	RxD	3	4	RTS	O		
		O	TxD	5	6	CTS	I	-	
		O	DTR	7	8	RI	I	-	
	-	PWR	GND	9	10	5V	PWR	-	1

Note 1: The COM1 and COM4 5V supply is fused with a common 1.1A resettable fuse.

The typical definition of the signals in the COM ports is as follows:

Signal	Description
TxD	Transmitted Data, sends data to the communications link. The signal is set to the marking state (-12V) on hardware reset when the transmitter is empty or when loop mode operation is initiated.
RxD	Received Data, receives data from the communications link.
DTR	Data Terminal Ready, indicates to the modem etc. that the on-board UART is ready to establish a communication link.
DSR	Data Set Ready, indicates that the modem etc. is ready to establish a communications link.
RTS	Request To Send, indicates to the modem etc. that the on-board UART is ready to exchange data.
CTS	Clear To Send, indicates that the modem or data set is ready to exchange data.
DCD	Data Carrier Detect, indicates that the modem or data set has detected the data carrier.
RI	Ring Indicator, indicates that the modem has received a ringing signal from the telephone line.

Available cable kit (DB9 adapter cables):

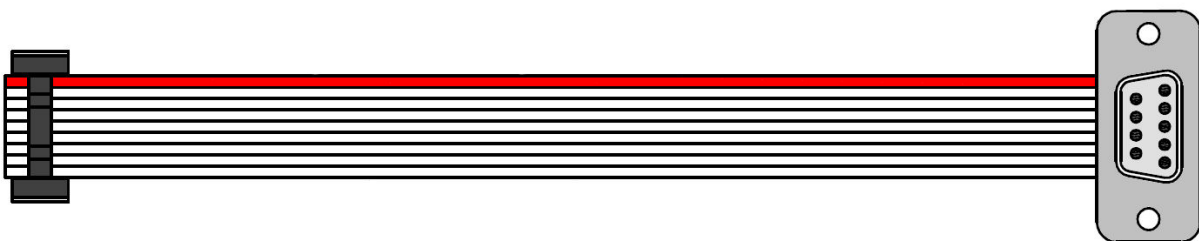

PN 821017 - 100 mm or PN 821016 - 200 mm

7.8 LPC Connector (J29)

The LPC connector is unsupported. The connector is type Foxconn HC11101-P0 or similar.

Note	Pull U/D	Ioh/Iol	Type	Signal	PIN		Signal	Type	Ioh/Iol	Pull U/D	Note
	-	-	PWR	LPC CLK	1	2	GND				
	-	-	PWR	LPC FRAME#	3		KEY				
				LPC RST#	5	6	+5V				
				LPC AD3	7	8	LPC AD2				
				+3V3	9	10	LPC AD1				
				LPC AD0	11	12	GND				
				SMB_CLK	13	14	SMB_DATA				
				SB3V3	15	16	LPC SERIRQ				
				GND	17	18	CLKRUN#				
				SUS_STAT#	19	20	NC				

7.9 Front Panel Connector (J5)

The Front Panel connector is a 24 pin connector type Wieson G2120HT0038-016 or similar.

Note	Pull U/D	Ioh/Iol	Type	Signal	PIN		Signal	Type	Ioh/Iol	Pull U/D	Note
	-	-	PWR	USB0_5V	1	2	USB1_5V	PWR	-	-	
	-	-		USB0-	3	4	USB1-		-	-	
	-	-		USB0+	5	6	USB1+		-	-	
	-	-	PWR	GND	7	8	GND	PWR	-	-	
	-	-	NC	NC	9	10	LINE2-L		-	-	
	-	-	PWR	+5V	11	12	+5V	PWR	-	-	
	-	25/25mA	O	SATA_LED#	13	14	SUS_LED	O	7mA	-	
	-	-	PWR	GND	15	16	PWRBTN_IN#	I		1K1	
	4K7	-	I	RSTIN#	17	18	GND	PWR	-	-	
	-	-	PWR	SB3V3	19	20	LINE2-R		-	-	
	-	-	PWR	AGND	21	22	AGND	PWR	-	-	
	-	-	AI	MIC2-L	23	24	MIC2-R	AI	-	-	

Signal	Description
USB0_5V/USB1_5V	5V supply for external devices. SB5V is supplied during powerdown to allow wakeup on USB device activity. Protected by independent resettable 1.1A fuse.
USB0+/USB0-	Universal Serial Bus Port 0 Differentials: Bus Data/Address/Command Bus.
USB1+/USB1-	Universal Serial Bus Port 1 Differentials: Bus Data/Address/Command Bus.
+5V	Maximum load is 1A if using IDC connector or 2A if using crimp terminals .
SATA_LED#	SATA Activity LED (active low signal). 3V3 output when passive.
SUS_LED	Suspend Mode LED (active high signal). Output 3.3V via 470Ω.
PWRBTN_IN#	Power Button In. Toggle this signal low to start the ATX / BTX PSU and boot the board.
RSTIN#	Reset Input. When pulled low for a minimum 16ms, the reset process will be initiated. The reset process continues even though the Reset Input is kept low.
LINE2	Line2 is second stereo Line signals
MIC2	MIC2 is second stereo microphone input.
SB3V3	Standby 3.3V voltage
AGND	Analogue Ground for Audio

Note: In order to meet the requirements of USB standard, the 5V input supply must be at least 5.00V.

Available cable kit:

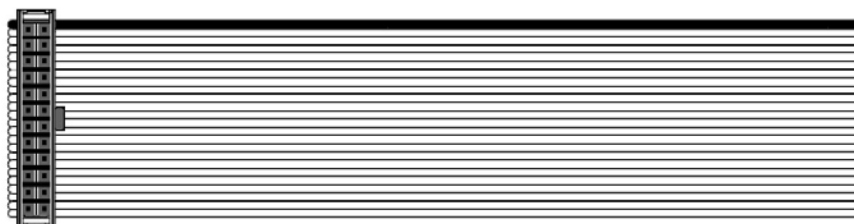

PN 821042 Cable Front Panel Open-End, 300 mm

7.10 CPU/System Fan Connectors (J25, J24)

The CPU Fan connector and the System Fan connector are identical 4 pin type connectors. The type is Tyco 1470947-1 or similar.

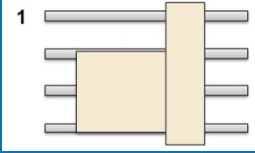
Header	Pin	Signal	Description	Type
	1	PWM	PWM output	0-3.3
	2	TACHO	Tacho signal (open drain)	I
	3	12V	Power +12V	PWR
	4	GND	Ground	PWR

Signal	Description
PWM	PWM is output signal used to control the fan speed (only for 4-wire Fans).
Tacho	Tarcho input signal is used to monitor the rotation speed RPM (Rotation Per Minute). Prepared for two pulses per turn.

The CPU Fan is premounted on the KTA70M/mITX.

PN 1052-6341 for R-252F and R-460L versions.

PN **TBD** for R-460H version.

The fan is a 12V Ball Bearing type.

PWM 0 – 100% control making speed in range 0 – 7000 RPM
(Startup PWM is 30%)

Power consumption up to 2,4W

MTBF 70000 Hours @ 40°C

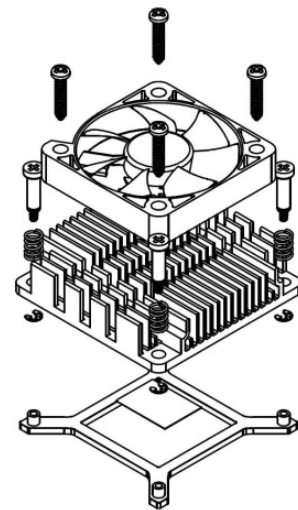

7.11 Feature Connector (J26)

The Feature Connector is a 44 pin connector, 2 mm pitch, type Foxconn HS5422F or similar.

Note	Pull U/D	Ioh/Iol	Type	Signal	PIN	Signal	Type	Ioh/Iol	Pull U/D	Note
2	2M/	-	I	CASE_OPEN#	1 2	SMBC		/4mA	10K/	1
	-	25/25mA	0	S5#	3 4	SMBD		/4mA	10K/	1
	-	25/25mA	0	PWR_OK	5 6	EXT_BAT	PWR	-	-	
4	-		0	FAN3OUT	7 8	FAN3IN	I	-	10K/	4
	-	-	PWR	SB3V3	9 10	SB5V	PWR	-	-	
	-		IOT	GPI00	11 12	GPI01	IOT		-	
	-		IOT	GPI02	13 14	GPI03	IOT		-	
	-		IOT	GPI04	15 16	GPI05	IOT		-	
	-		IOT	GPI06	17 18	GPI07	IOT		-	
	-	-	PWR	GND	19 20	GND	PWR	-	-	
	-		I	GPI08	21 22	GPI09	I		-	
3	-		NC	GPI010	23 24	GPI011	NC		-	3
	-		I	GPI012	25 26	GPI013	IOT		-	
	-		IOT	GPI014	27 28	GPI015	IOT		-	
	-		IOT	GPI016	29 30	GPI017	NC		-	3
	-	-	PWR	GND	31 32	GND	PWR	-	-	
	-	8/8mA	0	EGCLK	33 34	EGCS#	0	8/8mA	-	
	-	8/8mA		EGAD	35 36	TMA0	0			
	-		PWR	+12V	37 38	GND	PWR	-	-	
4	-		0	FAN4OUT	39 40	FAN4IN	I	-	10K/	4
	-	-	PWR	GND	41 42	GND	PWR	-	-	
	-	-	PWR	GND	43 44	S3#	0	25/25mA	-	

- Notes:**
1. Pull-up to SB3V3.
 2. Pull-up to on-board Battery.
 3. Not connected, used for onboard feature.
 4. Not supported.

Available cable kit:

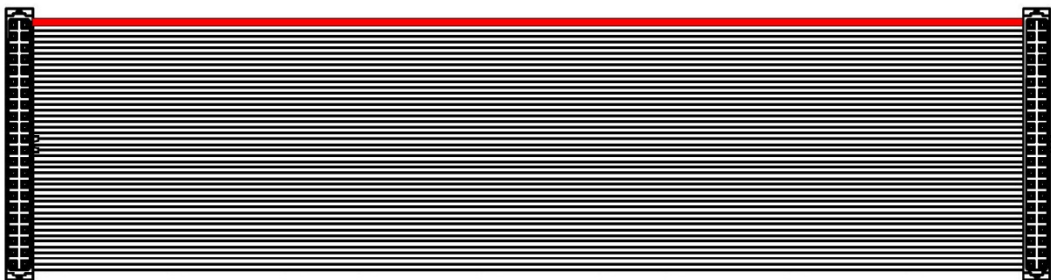

PN 1052-5885 Cable, Feature 44pol 1 to1, 300mm

Signal	Description
CASE_OPEN# *	CASE OPEN, used to detect if the system case has been opened. This signal's status is readable, so it may be used like a GPI when the Intruder switch is not required.
SMBC	SMBus Clock signal
SMBD	SMBus Data signal
S3#	S3 sleep mode, active low output, optionally used to deactivate external system.
S5#	S5 sleep mode, active low output, optionally used to deactivate external system.
PWR_OK	PoWeR OK, signal is high if no power failures are detected. (This is not the same as the P_OK signal generated by ATX PSU).
EXT_BAT *	(EXternal BATtery) option for connecting + terminal of an external primary cell battery (2.5 - 3.47 V) (- terminal connected to GND). The external battery is protected against charging and can be used with/without the on-board battery installed.
FAN3OUT	Not Supported
FAN3IN	Not Supported
FAN4OUT	Not Supported
FAN4IN	Not Supported
SB3V3	+3.3V StandBy voltage, max. load 1 Amp
SB5V	+5V StandBy voltage
GPI00..17 *	General Purpose Inputs / Output. These Signals may be controlled or monitored through the use of the KT-API-V2 (Application Programming Interface). GPIO10, GPIO11 and GPIO17 are not supported (not connected).
EGCLK *	Extend GPIO Clock signal
EGAD *	Extend GPIO Address Data signal
EGCS# *	Extend GPIO Chip Select signal, active low
TMA0	Timer Output
+12V	+12V, max. load 1 Amp.

(*) = Not verified.

Available Temperature Sensor cable kit (for System Fan Temperature Cruise, selected in BIOS):

Based on Maxim DS18B20, Accurate to $\pm 0.5^{\circ}\text{C}$ over the range of -10°C to $+85^{\circ}\text{C}$
Feature connector 3.3V (Pin 9), GND (Pin 19) and GPIO16 (Pin 29)

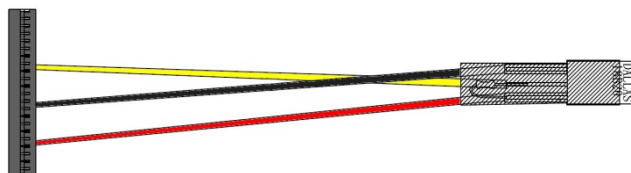

PN1053-4925 Cable Temperature Sensor - 44P, 400 mm

GPIO in more details:

The GPIO's are controlled via the ITE IT8516F Embedded Controller. Each GPIO has 100pF to ground, clamping Diode to 3V3 and has multiplexed functionality. Some pins can be DAC (Digital to Analogue Converter output), PWM (Pulse Width Modulated signal output), ADC (Analogue to Digital Converter input), TMRI (Timer Counter Input), WUI (Wake Up Input), RI (Ring Indicator Input) or some special function.

Signal	IT8516F pin name	Type	Description
GPIO0	DAC0/GPJ0	A0/IOS	
GPIO1	DAC1/GPJ1	A0/IOS	
GPIO2	DAC2/GPJ2	A0/IOS	
GPIO3	DAC3/GPJ3	A0/IOS	
GPIO4	PWM2/GPA2	08/IOS	
GPIO5	PWM3/GPA3	08/IOS	
GPIO6	PWM4/GPA4	08/IOS	
GPIO7	PWM5/GPA5	08/IOS	
GPIO8	ADC0/GPI0	AI/IS	
GPIO9	ADC1/GPI1	AI/IS	
GPIO10	ADC2/GPI2	AI/IS	Reserved, used for System Temperature
GPIO11	ADC3/GPI3	AI/IS	Reserved, used for +12V monitoring
GPIO12	ADC4/WUI28/GPI4	AI/IS/IS	
GPIO13	RI1#/WUI0/GPDO	IS/IS/IOS	
GPIO14	RI2#/WUI1/GPD1	IS/IS/IOS	
GPIO15	TMRI0/WUI2/GPC4	IS/IS/IOS	
GPIO16	TMRI1/WUI3/GPC6	IS/IS/IOS	Optionally for Cable Temperature sensor
GPIO17	L80HLAT/BAO/WUI24/GPE0	04/04/IS/IOS	Reserved, used for Sync

Feature Break-out board:

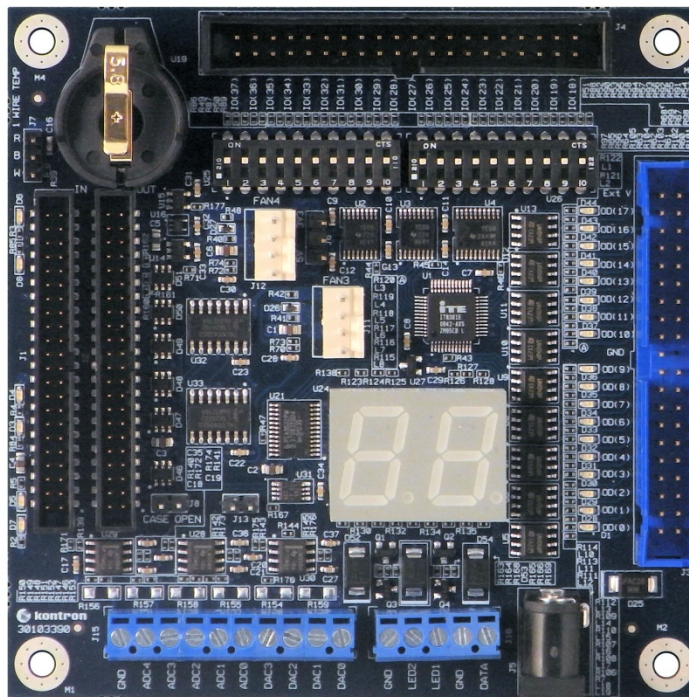

PN 820978 Feature B0B (Break-Out-Board)

7.12 KBD/MSE (J27)

Attachment of a PS/2 keyboard/mouse can be done through the pinrow connector KBDMSE (J27) type Molex 22-23-2061 or similar.

Both interfaces utilize open-drain signalling with on-board pull-up.

The PS/2 mouse and keyboard is supplied from SB5V when in standby mode in order to enable keyboard or mouse activity to bring the system out from power saving states. The supply is provided through a 1.1A resettable fuse.

PIN	Signal	Type	Ioh/Iol	Pull U/D	Note
1	KBDCLK	IOD	/14mA	2K7	
2	KBDDAT	IOD	/14mA	2K7	
3	MSCLK	IOD	/14mA	2K7	
4	MSDAT	IOD	/14mA	2K7	
5	5V/SB5V	PWR	-	-	
6	GND	PWR	-	-	

Signal Description – Keyboard & and mouse Connector (KBDMSE).

Signal	Description
MSCLK	Bi-directional clock signal used to strobe data/commands from/to the PS/2 mouse.
MSDAT	Bi-directional serial data line used to transfer data from or commands to the PS/2 mouse.
KDBCLK	Bi-directional clock signal used to strobe data/commands from/to the PC-AT keyboard.
KBDDAT	Bi-directional serial data line used to transfer data from or commands to the PC-AT keyboard.

Available cable kit:

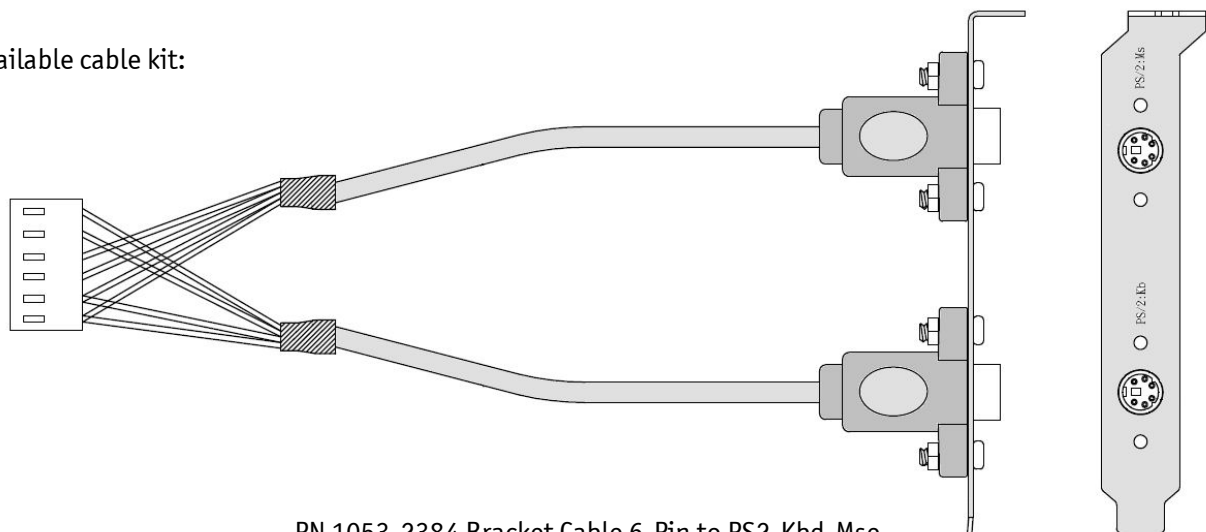

PN 1053-2384 Bracket Cable 6-Pin to PS2-Kbd-Mse

8 Slot Connectors (PCI-Express, miniPCIe, SATA, mSATA)

8.1 PCIex8 (in x16 slot) (J7)

The PCIex8 (8-lane PCI Express) is available through a PCIe x16 slot and support PCIe 2.0. The slot can be used for external PCI Express cards inclusive graphics card and dedicated TMDS passive card. The slot is located nearest the edge of the board. Maximum theoretical bandwidth using 8 lanes is 8 GB/s.

Note	Type	Signal	PIN		Signal	Type	Note
		+12V	B1	A1	GND via 0 Ohm		
		+12V	B2	A2	+12V		
		+12V	B3	A3	+12V		
		GND	B4	A4	GND		
		SMB_CLK	B5	A5	NC		
		SMB_DATA	B6	A6	SCL5-AUX5P		
		GND	B7	A7	SCA5-AUX5N		
		+3V3	B8	A8	NC		
		DP5 HP	B9	A9	+3V3		
		SB3V3	B10	A10	+3V3		
		WAKE#	B11	A11	RST#		
		NC	B12	A12	GND		
		GND	B13	A13	PCIE_x16 CLKP		
		PEG_TXP[0]	B14	A14	PCIE_x16 CLKN		
		PEG_TXN[0]	B15	A15	GND		
		GND	B16	A16	PEG_RXP[0]		
		CLKREQ	B17	A17	PEG_RXN[0]		
		GND	B18	A18	GND		
		PEG_TXP[1]	B19	A19	NC		
		PEG_TXN[1]	B20	A20	GND		
		GND	B21	A21	PEG_RXP[1]		
		GND	B22	A22	PEG_RXN[1]		
		PEG_TXP[2]	B23	A23	GND		
		PEG_TXN[2]	B24	A24	GND		
		GND	B25	A25	PEG_RXP[2]		
		GND	B26	A26	PEG_RXN[2]		
		PEG_TXP[3]	B27	A27	GND		
		PEG_TXN[3]	B28	A28	GND		
		GND	B29	A29	PEG_RXP[3]		
		NC	B30	A30	PEG_RXN[3]		
		CLKREQ	B31	A31	GND		
		GND	B32	A32	NC		
		PEG_TXP[4]	B33	A33	NC		
		PEG_TXN[4]	B34	A34	GND		
		GND	B35	A35	PEG_RXP[4]		

		GND	B36	A36	PEG_RXN[4]		
		PEG_TXP[5]	B37	A37	GND		
		PEG_TXN[5]	B38	A38	GND		
		GND	B39	A39	PEG_RXP[5]		
		GND	B40	A40	PEG_RXN[5]		
		PEG_TXP[6]	B41	A41	GND		
		PEG_TXN[6]	B42	A42	GND		
		GND	B43	A43	PEG_RXP[6]		
		GND	B44	A44	PEG_RXN[6]		
		PEG_TXP[7]	B45	A45	GND		
		PEG_TXN[7]	B46	A46	GND		
		GND	B47	A47	PEG_RXP[7]		
		CLKREQ	B48	A48	PEG_RXN[7]		
		GND	B49	A49	GND		
		NC	B50	A50	NC		
		NC	B51	A51	GND		
		GND	B52	A52	NC		
		GND	B53	A53	NC		
		NC	B54	A54	GND		
		NC	B55	A55	GND		
		GND	B56	A56	NC		
		GND	B57	A57	NC		
		NC	B58	A58	GND		
		NC	B59	A59	GND		
		GND	B60	A60	NC		
		GND	B61	A61	NC		
		NC	B62	A62	GND		
		NC	B63	A63	GND		
		GND	B64	A64	NC		
		GND	B65	A65	NC		
		NC	B66	A66	GND		
		NC	B67	A67	GND		
		GND	B68	A68	NC		
		GND	B69	A69	NC		
		NC	B70	A70	GND		
		NC	B71	A71	GND		
		GND	B72	A72	NC		
		GND	B73	A73	NC		
		NC	B74	A74	GND		
		NC	B75	A75	GND		
		GND	B76	A76	NC		
		GND	B77	A77	NC		
		NC	B78	A78	GND		
		NC	B79	A79	GND		
		GND	B80	A80	NC		
		CLKREQ	B81	A81	NC		
		NC	B82	A82	GND		

8.2 PCIex4 (J6)

The PCIex4 (4-lane PCI Express) is available through a PCIe x16 slot and support PCIe 2.0. The slot can be used for external PCI Express cards inclusive graphics card. The slot is located nearest the CPU of the board. Maximum theoretical bandwidth using 4 lanes is 4 GB/s.

Note	Type	Signal	PIN		Signal	Type	Note
		+12V	B1	A1	GND via 0 ohm		
		+12V	B2	A2	+12V		
		+12V	B3	A3	+12V		
		GND	B4	A4	GND		
		SMB_CLK	B5	A5	NC		
		SMB_DATA	B6	A6	NC		
		GND	B7	A7	NC		
		+3V3	B8	A8	NC		
		NC	B9	A9	+3V3		
		SB3V3	B10	A10	+3V3		
		WAKE#	B11	A11	RST#		
		NC	B12	A12	GND		
		GND	B13	A13	PCIE_x16 CLK		
		PEG_TXP[0]	B14	A14	PCIE_x16 CLK#		
		PEG_TXN[0]	B15	A15	GND		
		GND	B16	A16	PEG_RXP[0]		
		CLKREQ	B17	A17	PEG_RXN[0]		
		GND	B18	A18	GND		
		PEG_TXP[1]	B19	A19	NC		
		PEG_TXN[1]	B20	A20	GND		
		GND	B21	A21	PEG_RXP[1]		
		GND	B22	A22	PEG_RXN[1]		
		PEG_TXP[2]	B23	A23	GND		
		PEG_TXN[2]	B24	A24	GND		
		GND	B25	A25	PEG_RXP[2]		
		GND	B26	A26	PEG_RXN[2]		
		PEG_TXP[3]	B27	A27	GND		
		PEG_TXN[3]	B28	A28	GND		
		GND	B29	A29	PEG_RXP[3]		
		NC	B30	A30	PEG_RXN[3]		
		CLKREQ	B31	A31	GND		
		GND	B32	A32	NC		
		NC	B33	A33	NC		
		NC	B34	A34	GND		
		GND	B35	A35	NC		
		GND	B36	A36	NC		
		NC	B37	A37	GND		
		NC	B38	A38	GND		

		GND	B39	A39	NC		
		GND	B40	A40	NC		
		NC	B41	A41	GND		
		NC	B42	A42	GND		
		GND	B43	A43	NC		
		GND	B44	A44	NC		
		NC	B45	A45	GND		
		NC	B46	A46	GND		
		GND	B47	A47	NC		
		CLKREQ	B48	A48	NC		
		GND	B49	A49	GND		
		NC	B50	A50	NC		
		NC	B51	A51	GND		
		GND	B52	A52	NC		
		GND	B53	A53	NC		
		NC	B54	A54	GND		
		NC	B55	A55	GND		
		GND	B56	A56	NC		
		GND	B57	A57	NC		
		NC	B58	A58	GND		
		NC	B59	A59	GND		
		GND	B60	A60	NC		
		GND	B61	A61	NC		
		NC	B62	A62	GND		
		NC	B63	A63	GND		
		GND	B64	A64	NC		
		GND	B65	A65	NC		
		NC	B66	A66	GND		
		NC	B67	A67	GND		
		GND	B68	A68	NC		
		GND	B69	A69	NC		
		NC	B70	A70	GND		
		NC	B71	A71	GND		
		GND	B72	A72	NC		
		GND	B73	A73	NC		
		NC	B74	A74	GND		
		NC	B75	A75	GND		
		GND	B76	A76	NC		
		GND	B77	A77	NC		
		NC	B78	A78	GND		
		NC	B79	A79	GND		
		GND	B80	A80	NC		
		CLKREQ	B81	A81	NC		
		NC	B82	A82	GND		

8.3 mPCIe connector (J38)

The mPCIe (mini PCI Express) port is available through connector located on the backside of the board. The mPCI is PCIe 2.0 compliant.

Header	Pin	Signal	Description	Type	Pin	Signal	Description	Type
	1	Wake#	Wake event	I-3.3	2	3.3V	Power +3.3V	PWR
	3	N.C.	-	NC	4	Gnd	Ground	PWR
	5	N.C.	-	NC	6	1.5V	Power +1.5V	PWR
	7	Clkreq#	Clock request	I-3.3	8	N.C.	-	NC
	9	GND	Ground	PWR	10	N.C.	-	NC
	11	PE_Clk-	PCIe® clock-	DSO	12	N.C.	-	NC
	13	PE_Clk+	PCIe® clock+	DSO	14	N.C.	-	NC
	15	GND	Ground	PWR	16	N.C.	-	NC
	17	N.C.	-	NC	18	Gnd	Ground	PWR
	19	N.C.	-	NC	20	W_Disable#	Wireless disable	0-3.3
	21	GND	Ground	PWR	22	PE_RST#	PCIe® reset	0-3.3
	23	PE_RX-	PCIe® receive-	DSI	24	3.3V	Power +3.3V	PWR
	25	PE_RX+	PCIe® receive+	DSI	26	Gnd	Ground	PWR
	27	Gnd	Ground	PWR	28	1.5V	Power +1.5V	PWR
	29	Gnd	Ground	PWR	30	I2C_Clk	I2C™ clock	0-3.3
	31	PE_TX-	PCIe® transmit-	DSO	32	I2C_Data	I2C™ data	IO-3.3
	33	PE_TX+	PCIe® transmit+	DSO	34	Gnd	Ground	PWR
	35	Gnd	Ground	PWR	36	USB2-	Diff. pair USB2 -	DSIO-3.3
	37	Gnd	Ground	PWR	38	USB2+	Diff. pair USB2 +	DSIO-3.3
	39	3.3V	Power +3.3V	PWR	40	Gnd	Ground	PWR
	41	3.3V	Power +3.3V	PWR	42	N.C.	-	NC
	43	Gnd	Ground	PWR	44	N.C.	-	NC
	45	N.C.	-	NC	46	N.C.	-	NC
	47	N.C.	-	NC	48	1.5V	Power +1.5V	PWR
	49	N.C.	-	NC	50	Gnd	Ground	PWR
	51	N.C.	-	NC	52	3.3V	Power +3.3V	PWR

8.4 SATA0, SATA1, SATA2, SATA3, SATA4 (J12, J13, J9, J11, J10)

The five SATA ports comply with SATA 3.0 and supports IDE emulation mode, AHCI (Advanced Host Controller Interface) 1.3 mode and RAID mode (RAID 0 and RAID 1) across all 5 ports.

The SATA 3.0 supports transfer rates up to 6 Gbit/s, but also SATA 1.0 and SATA 2.0 transfer rates are supported, 1.5 Gbit/s and 3.0 Gbit/s respectively.

The S-ATA[®] interface is available through standard L-type connector (7 pins).

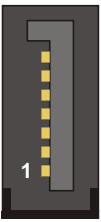
Header	Pin	Signal	Description	Type
	1	GND	Ground	PWR
	2	TX+	Transmit (positive)	DSO
	3	TX-	Transmit (negative)	DSO
	4	GND	Ground	PWR
	5	RX-	Receive (negative)	DSI
	6	RX+	Receive (positive)	DSI
	7	GND	Ground	PWR

Available cable kit:



PN 821035 Cable SATA 500mm

8.5 mSATA Connector (J39)

The mSATA port is located on the backside of the KTA70M.

The mSATA interface comply with SATA 3.0 and it supports USB (port USB2)

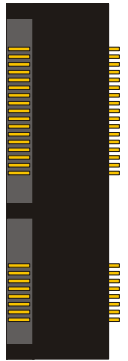

Header	Pin	Signal	Description	Type	Pin	Signal	Description	Type
	1	Wake#	Wake event	I-3.3	2	3.3V	Power +3.3V	PWR
	3	N.C.	-	NC	4	Gnd	Ground	PWR
	5	N.C.	-	NC	6	1.5V	Power +1.5V	PWR
	7	Clkreq#	Clock request	I-3.3	8	N.C.	-	NC
	9	Gnd	Ground	PWR	10	N.C.	-	NC
	11	PE_CLK-	PCIe® clock-	DSO	12	N.C.	-	NC
	13	PE_CLK+	PCIe® clock+	DSO	14	N.C.	-	NC
	15	Gnd	Ground	PWR	16	N.C.	-	NC
	17	N.C.	-	NC	18	Gnd	Ground	PWR
	19	N.C.	-	NC	20	W_Disable#	Wireless disable	O-3.3
	21	Gnd	Ground	PWR	22	PE_RST#	PCIe® reset	O-3.3
	23	SATA_RX+	S-ATA® receive+	DSI	24	3.3V	Power +3.3V	PWR
	25	SATA_RX-	S-ATA® receive-	DSI	26	Gnd	Ground	PWR
	27	Gnd	Ground	PWR	28	1.5V	Power +1.5V	PWR
	29	Gnd	Ground	PWR	30	I2C_Clk	I2C™ clock	IO-3.3
	31	SATA_TX-	S-ATA® transmit-	DSO	32	I2C_Data	I2C™ data	IO-3.3
	33	SATA_TX+	S-ATA® transmit+	DSO	34	Gnd	Ground	PWR
	35	Gnd	Ground	PWR	36	N.C.	-	NC
	37	Gnd	Ground	PWR	38	N.C.	-	NC
	39	3.3V	Power +3.3V	PWR	40	Gnd	Ground	PWR
	41	3.3V	Power +3.3V	PWR	42	N.C.	-	NC
	43	Gnd	Ground	PWR	44	N.C.	-	NC
	45	N.C.	-	NC	46	N.C.	-	NC
	47	N.C.	-	NC	48	1.5V	Power +1.5V	PWR
	49	N.C.	-	NC	50	Gnd	Ground	PWR
	51	Sel_SATA#	S-ATA® identification	I-1.8	52	3.3V	Power +3.3V	PWR

9 BIOS

The BIOS Setup is used to view and configure BIOS settings for the board. The BIOS Setup is accessed by pressing the -key after the Power-On Self-Test (POST) memory test begins and before the operating system boot begins.

The BIOS settings will be loaded automatically when loading “Restore Default” see “Save & Exit” menu. In this Users Guide the default settings are indicated by **bold**. Please notice that “Restore User Defaults” might have different set of default values.

9.1 Main

Aptio Setup Utility – Copyright © 2012 American Megatrends, Inc.

Main Advanced Chipset Boot Security Save & Exit

BIOS Information		Choose the system default language.
BIOS Vendor	American Megatrends	
Core Version	4.6.5.3	
Compliance	UEFI 2.3; PI 1.2	
Project Version	KTA7X025 x64	
Build Date and Time	09/26/2013 09:12:19	
Memory Information		
Total Memory	8176 MB (DDR3)	
EC Firmware Version	V1.21 07/05/13	
Board Information		
Product Name	KTA70/mITX	
PCB ID	02	
Serial #	01140641	
Part #	66020300	
Boot Count	78	
System Language	[English]	→← : Select Screen
System Date	[Mon 11/04/2013]	↑↓ : Select Item
System Time	[11:21:40]	Enter: Select
Access Level	Administrator	+/- : Change Opt.
		F1: General Help
		F2: Previous Values
		F3: Optimized Defaults
		F4: Save & Exit
		ESC: Exit

Version 2.15.1227. Copyright © 2012 American Megatrends, Inc

Blue text for settings that can be changed. White text for actual setting to be changed via the control keys. Black text for settings that cannot be changed via control keys.

The following table describes the changeable settings:

Feature	Options	Description
System Language	English	(only English available)
System Date	MM/DD/YYYY	Set the system date.
System Time	HH:MM:SS	Set the system time.

9.2 Advanced

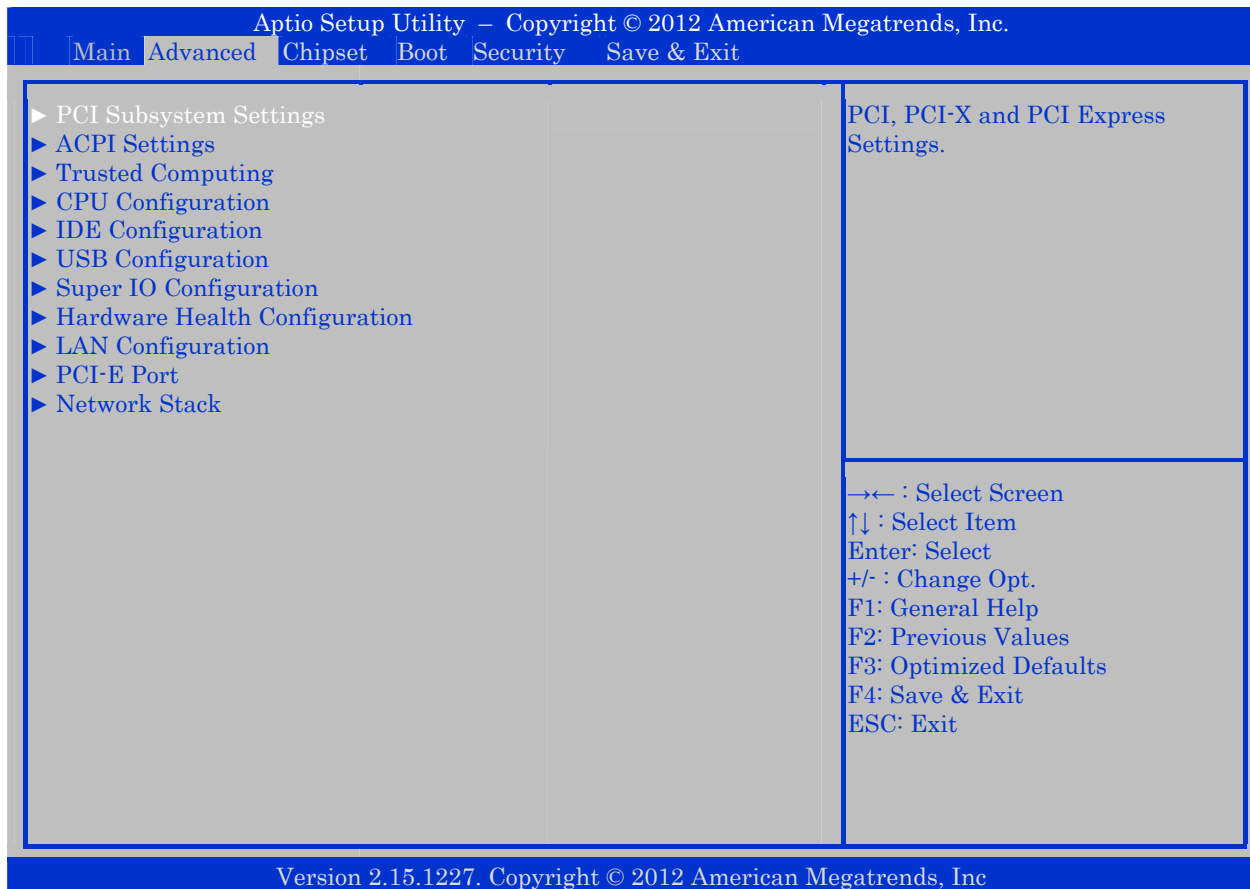

The Advanced (main) menu contains only submenu selections which will be described in more details on the following pages.

In order to make a selection of a submenu activated the ↑↓ keys until the requested submenu becomes white color, then activate the <Enter>.

9.2.1 Advanced - PCI Subsystem Settings

Aptio Setup Utility – Copyright © 2012 American Megatrends, Inc.

Advanced

PCI Bus Driver Version	V 2.05.02	Value to be programmed into PCI Latency Timer Register.
PCI Common Settings PCI Latency Timer VGA Palette Snoop PERR# Generation SERR# Generation	[32 PCI Bus Clocks] [Disabled] [Disabled] [Disabled]	
▶ PCI Express Settings		→← : Select Screen ↑↓ : Select Item Enter: Select +/- : Change Opt. F1: General Help F2: Previous Values F3: Optimized Defaults F4: Save & Exit ESC: Exit

Version 2.15.1227. Copyright © 2012 American Megatrends, Inc

Function	Selection	Description
PCI Latency Timer	32 PCI Bus Clocks 64 PCI Bus Clocks 96 PCI Bus Clocks 128 PCI Bus Clocks 160 PCI Bus Clocks 192 PCI Bus Clocks 224 PCI Bus Clocks 248 PCI Bus Clocks	Value to be programmed into PCI Latency Timer Register.
VGA Palette Snoop	Disabled Enabled	Enables or Disables VGA Palette Registers Snooping.
PERR# Generation	Disabled Enabled	Enables or Disables PCI Device to Generate PERR#.
SERR# Generation	Disabled Enabled	Enables or Disables PCI Device to Generate SERR#.

Note: The selection in **bold** is the default selection.

PCI Express Settings

Aptio Setup Utility – Copyright © 2012 American Megatrends, Inc.

Advanced

PCI Express Device Register Settings Relaxed Ordering [Disabled] Extended Tag [Disabled] No Snoop [Enabled] Maximum Payload [Auto] Maximum Read Request [Auto]		Enables or Disables PCI Express Device Relaxed Ordering.
PCI Express Link Register Settings ASPM Support [Disabled] WARNING: Enabling ASPM may cause some PCI-E devices to fail Extended Synch [Disabled]		
Link Training Retry [5] Link Training Timeout (uS) 100 Unpopulated Links [Keep Link ON]		→← : Select Screen ↑↓ : Select Item Enter: Select +/- : Change Opt. F1: General Help F2: Previous Values F3: Optimized Defaults F4: Save & Exit ESC: Exit

Version 2.15.1227. Copyright © 2012 American Megatrends, Inc

Function	Selection	Description
Relaxed Ordering	Disabled Enabled	Enables or Disables PCI Express Device Relaxed Ordering.
Extended Tag	Disabled Enabled	If Enabled allows Device to use 8-bit Tag field as a requester.
No Snoop	Disabled Enabled	Enables or Disables PCI Express Device No Snoop option.
Maximum Payload	Auto 128 Bytes 256 Bytes 512 Bytes 1024 Bytes 2048 Bytes 4096 Bytes	Set Maximum Payload of PCI Express Device or allow System BIOS to select the value.
Maximum Read Request	Auto 128 Bytes 256 Bytes 512 Bytes 1024 Bytes 2048 Bytes 4096 Bytes	Set Maximum Read Request Size of PCI Express Device or allow System BIOS to select the value.
ASPM Support	Disabled Auto Force L0s	Set the ASPM Level: Force L0s - Force all links to L0s State. Auto – BIOS auto configure Disable – Disabled ASPM
Extended Synch	Disabled Enabled	If Enabled allows generation of Extended Synchronization patterns.
Link Training Retry	Disabled 2 3 5	Defines number of Retry Attempts software will take to retrain the link if previous training attempt was unsuccessful.
Link Training Timeout (uS)	100	Defines number of Microseconds software will wait before polling `Link Training` bit in Link Status register. Value range from 10 to 1000uS.
Unpopulated Links	Keep Link ON Disabled	In order to save power, software will disable unpopulated PCI Express links, if this option set to Disabled.

9.2.2 Advanced - APCI Settings

Aptio Setup Utility – Copyright © 2012 American Megatrends, Inc.

Advanced

ACPI Settings		Enables or Disables BIOS APCI Auto Configuration.
Enable ACPI Auto Configuration	[Disabled]	
Enable Hibernation	[Enabled]	
ACPI Sleep State	[S3 only (Suspend to ...)]	
Lock Legacy Resources	[Disabled]	

→← : Select Screen
 ↑↓ : Select Item
 Enter: Select
 +/- : Change Opt.
 F1: General Help
 F2: Previous Values
 F3: Optimized Defaults
 F4: Save & Exit
 ESC: Exit

Version 2.15.1227. Copyright © 2012 American Megatrends, Inc

Function	Selection	Description
Enable ACPI Auto Configuration	Disabled Enabled	Enables or Disables BIOS APCI Auto Configuration.
Enable Hibernation	Disabled Enabled	Enables or Disables System ability to Hibernate (OS/S4 Sleep State). This option may be not effective with some OS.
ACPI Sleep State	Suspend Disabled S3 only(Suspend to RAM)	Select ACPI sleep state the system will enter when the SUSPEND button is pressed.
Lock Legacy Resources	Disabled Enabled	Enables or Disables Lock Legacy Resources.

9.2.3 Advanced - Trusted Computing

Aptio Setup Utility – Copyright © 2012 American Megatrends, Inc.

Advanced		
Configuration Security Device Support TPM State Pending operation Current Status Information TPM Enabled Status: TPM Active Status: TPM Owner Status:	[Enable] [Enabled] [None] [Enabled] [Activated] [Unowned]	Enables or Disables BIOS support for security device. O.S. will not show Security Device. TCG EFI protocol and INT1A interface will not be available. →← : Select Screen ↑↓ : Select Item Enter: Select +/- : Change Opt. F1: General Help F2: Previous Values F3: Optimized Defaults F4: Save & Exit ESC: Exit

Version 2.15.1227. Copyright © 2012 American Megatrends, Inc

Function	Selection	Description
Security Device Support	Disabled Enabled	Enables or Disables BIOS support for security device. O.S. will not show Security Device. TCG EFI protocol and INT1A interface will not be available.
TPM State	Disabled Enabled	Enable/Disable Security Device. NOTE: Your Computer will reboot during restart in order to change State of the Device.
Pending operation	None Enable Take Ownership Disable Take Ownership TPM Clear	Schedule an Operation for the Security Device. NOTE: Your Computer will reboot during restart in order to change State of Security Device.

Note: TPM State and Pending operation are only visible if Security Device Support is Enabled followed by Save and Exit.

9.2.4 Advanced - CPU Configuration

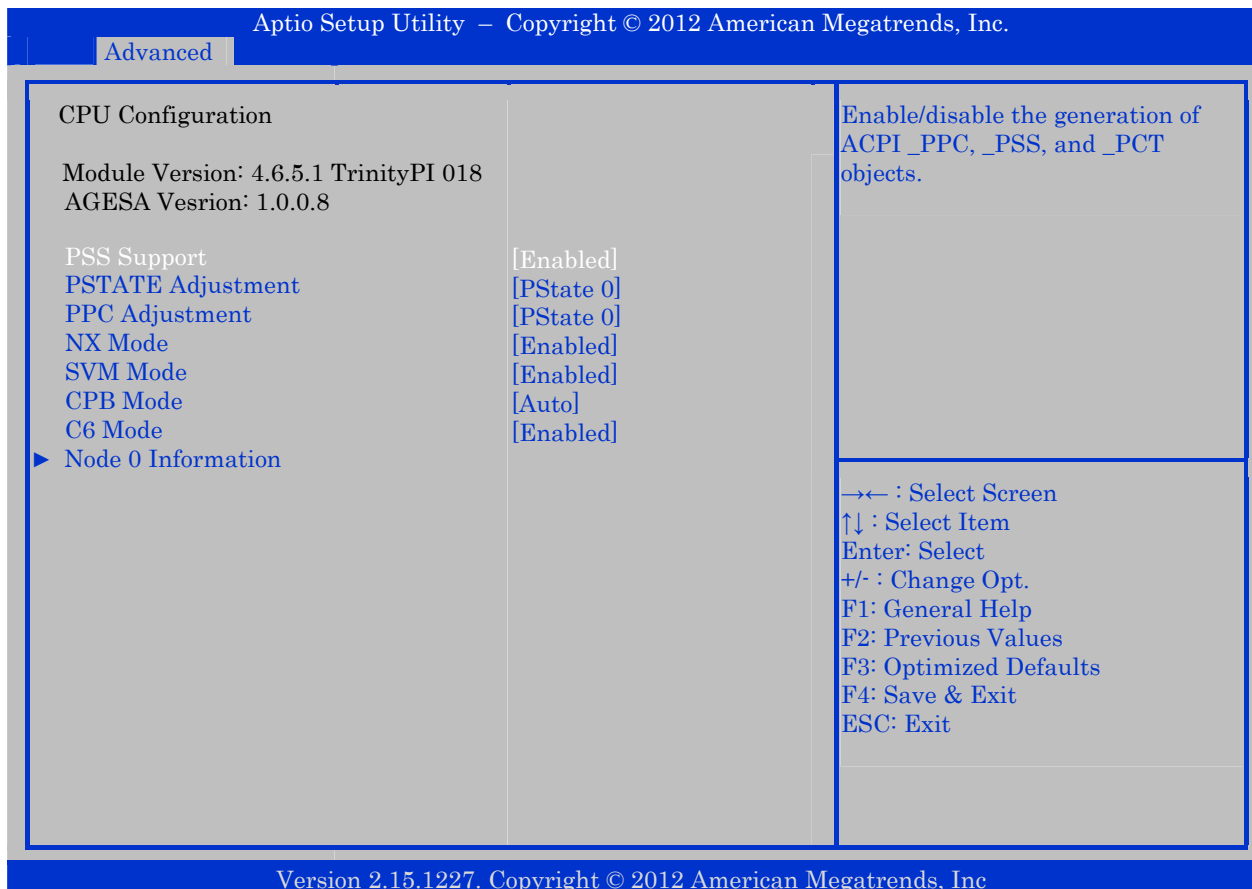

Function	Selection	Description
PSS Support	Disabled Enabled	Enable/disable the generation of ACPI_PPC, _PSS, and _PCT objects.
PSTATE Adjustment	PState 0 – Pstate 7	Provide to adjust startup P-state level.
PPC Adjustment	PState 0 – Pstate 4	Provide to adjust _PPC object.
NX Mode	Disabled Enabled	Enable/disable Ni-execute page protection Function.
SVM Mode	Disabled Enabled	Enable/disable CPU Virtualization.
CPB Mode	Auto Disabled	Auto/disable CPB.
C6 Mode	Disabled Enabled	Enable/disable C6.

Node 0 Information

Aptio Setup Utility – Copyright © 2012 American Megatrends, Inc.

Advanced

Socket0: AMD R-452L APU with Radeon™ HD Graphics
Quad Core Running @1639 MHz 375mV
Max Speed: 1600 MHz Intended Speed: 1600 MHz
Min Speed: 900 MHz
Microcode Patch Level: 6001116

----- Cache per Core -----
L1 Instruction Cache: 32 KB/2-way
L1 Data Cache: 16 KB/4-way
L2 Cache: 1024 KB/16-way
No L3 Cache Present

→← : Select Screen
↑↓ : Select Item
Enter: Select
+/- : Change Opt.
F1: General Help
F2: Previous Values
F3: Optimized Defaults
F4: Save & Exit
ESC: Exit

Version 2.15.1227. Copyright © 2012 American Megatrends, Inc

9.2.5 Advanced - IDE Configuration

Aptio Setup Utility – Copyright © 2012 American Megatrends, Inc.

Advanced

IDE Configuration	
SATA Port0	Maxtor 6L120M0 (122.9GB)
SATA Port1	Not Present
SATA Port2	Not Present
SATA Port3	Not Present
SATA Port4	Not Present
SATA Port5	Not Present

→← : Select Screen
↑↓ : Select Item
Enter: Select
+/- : Change Opt.
F1: General Help
F2: Previous Values
F3: Optimized Defaults
F4: Save & Exit
ESC: Exit

Version 2.15.1227. Copyright © 2012 American Megatrends, Inc

9.2.6 Advanced - USB Configuration

Aptio Setup Utility – Copyright © 2012 American Megatrends, Inc.

Advanced

<p>USB Configuration</p> <p>USB Devices: 1 Keyboard, 1 Mouse</p> <p>Legacy USB Support USB3.0 Support XHCI Hand-off EHCI Hand-off</p> <p>USB hardware delays and time-outs: USB transfer time-out Device reset time-out Device power-up delay</p>	<p>[Enabled] [Disabled] [Enabled] [Disabled]</p> <p>[20 sec} [20 sec} [Auto]</p>	<p>Enables Legacy USB support. AUTO option disables legacy support if no USB devices are connected. DISABLE option will keep USB devices available only for EFI applications.</p> <p>→← : Select Screen ↑↓ : Select Item Enter: Select +/- : Change Opt. F1: General Help F2: Previous Values F3: Optimized Defaults F4: Save & Exit ESC: Exit</p>
---	--	--

Version 2.15.1227. Copyright © 2012 American Megatrends, Inc

Function	Selection	Description
Legacy USB Support	Enabled Disabled Auto	Enables Legacy USB support. AUTO option disables legacy support if no USB devices are connected. DISABLE option will keep USB devices available only for EFI applications.
USB3.0 Support	Enabled Disabled	Enable/Disable USB3.0 (XHCI) Controller support.
XHCI Hand-off	Enabled Disabled	This is a workaround for Oses without XHCI hand-off support. The XHCI ownership change should be claimed by XHCI driver.
EHCI Hand-off	Enabled Disabled	This is a workaround for Oses without EHCI hand-off support. The EHCI ownership change should be claimed by EHCI driver.
USB transfer time-out	1, 5, 10, 20 sec	The time-out value for Control, Bulk, and Interrupt transfers.
Device reset time-out	10, 20 sec , 30, 40	USB mass storage device Start Unit command time-out.
Device power-up delay	Auto Manual	Maximum time the device will take before it properly reports itself to the Host Controller. `Auto` uses default value: for a Root port it is 100 ms, for a Hub port the delay is taken from Hub descriptor.

9.2.7 Advanced - Super IO Configuration

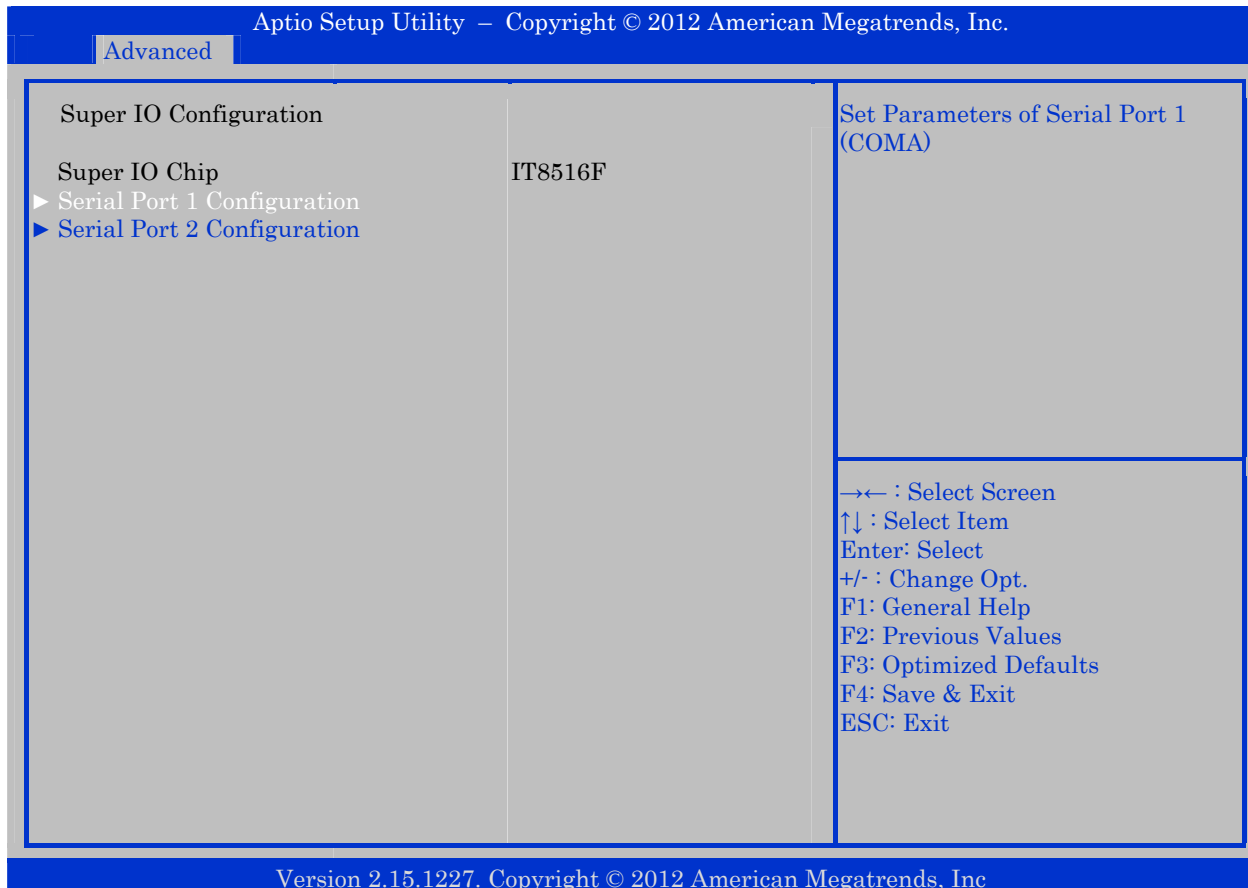

The 2 submenus are shown and described on the following pages.

Serial Port 1 Configuration

Aptio Setup Utility – Copyright © 2012 American Megatrends, Inc.

Advanced		
Serial Port 1 Configuration		Enable or Disable Serial Port (COM)
Serial Port	[Enabled]	
Device Settings	IO=3F8h; IRQ=4;	
Change Settings	[Auto]	
		→← : Select Screen ↑↓ : Select Item Enter: Select +/- : Change Opt. F1: General Help F2: Previous Values F3: Optimized Defaults F4: Save & Exit ESC: Exit
Version 2.15.1227. Copyright © 2012 American Megatrends, Inc		

Function	Selection	Description
Serial Port	Disabled Enabled	Enable or Disable Serial Port (COM)
Change Settings (Note1)	Auto IO=3F8h; IRQ=4; IO=3F8h; IRQ=3,4,5,6,7,10,11,12; IO=2F8h; IRQ=3,4,5,6,7,10,11,12; IO=3E8h; IRQ=3,4,5,6,7,10,11,12; IO=2E8h; IRQ=3,4,5,6,7,10,11,12;	Select an optimal setting for Super IO device.

Note1: only if Serial Port = Enabled

Serial Port 2 Configuration

Aptio Setup Utility – Copyright © 2012 American Megatrends, Inc.

Advanced

Serial Port 2 Configuration		Enable or Disable Serial Port (COM)
Serial Port Device Settings	[Enabled] IO=2F8h; IRQ=3;	
Change Settings	[Auto]	
		→← : Select Screen ↑↓ : Select Item Enter: Select +/- : Change Opt. F1: General Help F2: Previous Values F3: Optimized Defaults F4: Save & Exit ESC: Exit

Version 2.15.1227. Copyright © 2012 American Megatrends, Inc

Function	Selection	Description
Serial Port	Disabled Enabled	Enable or Disable Serial Port (COM)
Change Settings (Note1)	Auto IO=2F8h; IRQ=3; IO=3F8h; IRQ=3,4,5,6,7,10,11,12; IO=2F8h; IRQ=3,4,5,6,7,10,11,12; IO=3E8h; IRQ=3,4,5,6,7,10,11,12; IO=2E8h; IRQ=3,4,5,6,7,10,11,12;	Select an optimal setting for Super IO device.

Note1: only if Serial Port = Enabled

9.2.8 Advanced - Hardware Health Configuration

Aptio Setup Utility – Copyright © 2012 American Megatrends, Inc.

Advanced

Hardware Health Configuration		Use external connected sensor instead of onboard..
System Temperature	: 30°C/86°F	
CPU Temperature	: 49.10°C/120°F	
System Fan Speed	: 3134 RPM	
System Temperature Ext Type	[OneWire @ GPIO16]	
Fan Cruise Control	[Thermal]	
Fan Settings	35	
Fan Min limit	25	
Fan Max limit	80	
CPU Fan Speed	: 1374 RPM	
Fan Cruise Control	[Thermal]	
Fan Settings	50	
Fan Min limit	0	
Fan Max limit	100	
12V Supply	: 11.70 V	
Watchdog Function	0	

→← : Select Screen
 ↑↓ : Select Item
 Enter: Select
 +/- : Change Opt.
 F1: General Help
 F2: Previous Values
 F3: Optimized Defaults
 F4: Save & Exit
 ESC: Exit

Version 2.15.1227. Copyright © 2012 American Megatrends, Inc

Function	Selection	Description
System Temperature Ext Type (note1)	Disabled LM75 @ 0x90 OneWire @ GPIO16	
Fan Cruise Control (System Fan)	Disabled Thermal (note2) Speed	Disabled = Full speed. Thermal: Regulate according to specified °C. Speed: Regulate according to specified RPM.
Fan Settings (System Fan)	30 – 90 (note2,note3) 1000 – 9999 (note4)	
Fan Min limit (System Fan) (note5)	0 (note6)	Minimum PWM %, can be used to make sure fan is always active. Make sure Min limit < Max limit.
Fan Max limit (System Fan) (note5)	100 (note6)	Maximum PWM %, can be used to limit the fan noise. Make sure Min limit < Max limit.
Fan Cruise Control (CPU Fan)	Disabled Thermal Speed	Disabled = Full speed. Thermal: Regulate according to specified °C. Speed: Regulate according to specified RPM.
Fan Settings (CPU Fan)	30 – 90 (note3) 1000 – 9999 (note4)	
Fan Min limit (CPU Fan) (note7)	0 (note6)	Minimum PWM %, can be used to make sure fan is always active. Make sure Min limit < Max limit.
Fan Max limit (CPU Fan) (note7)	100 (note6)	Maximum PWM %, can be used to limit the fan noise. Make sure Min limit < Max limit.
Watchdog Function	0 - 255 (note8)	0 = Disabled. Enter the service interval in seconds before system will reset. Refer to manual how to reload the timer.

Note1: Only visible if external temperature sensor is connected.
(Example PN1053-4925 "Cable Temperature Sensor - 44P, 400 mm").

Note2: Only visible if external temperature sensor is connected and selected.

Note3: °C (if Fan Cruise Control = Thermal) use either digit keys to enter value or +/- keys to increase/decrease value. Don't use mix of digit keys and +/- keys.

Note4: RPM (if Fan Cruise Control = Speed) use either digit keys to enter value or +/- keys to increase/decrease value by 100. Don't use mix of digit keys and +/- keys.

Note5: Only visible if external temperature sensor is connected and if System Fan Cruise Control is Thermal.

Note6: Use number keys to enter value.

Note7: Only visible if CPU Fan Cruise Control is Thermal.

Note8: Seconds, use digit keys to enter value. Value 0 means Watchdog is disabled. Refer to "KT-API-V2 User Manual" to control the Watchdog via API or refer to "KT-API-V2 User Manual DLL" how to control Watchdog via Windows DLL.

9.2.9 Advanced - LAN Configuration

Aptio Setup Utility – Copyright © 2012 American Megatrends, Inc.

Advanced

LAN Configuration		Control of Ethernet Devices and PXE boot.
ETH1 Configuration (Upper)	[Enabled]	
MAC Address & Link status:	00E0F42A935F+	
ETH2 Configuration (Lower)	[Enabled]	
MAC Address & Link status:	00E0F42 A9360-	
		→← : Select Screen ↑↓ : Select Item Enter: Select +/- : Change Opt. F1: General Help F2: Previous Values F3: Optimized Defaults F4: Save & Exit ESC: Exit

Version 2.15.1227. Copyright © 2012 American Megatrends, Inc

Function	Selection	Description
ETH1 Configuration (Upper)	Disabled Enabled With PXE boot	Control of Ethernet Devices and PXE boot.
ETH2 Configuration (Lower)	Disabled Enabled With PXE boot	Control of Ethernet Devices and PXE boot.

9.2.10 Advanced – PCI-E Port

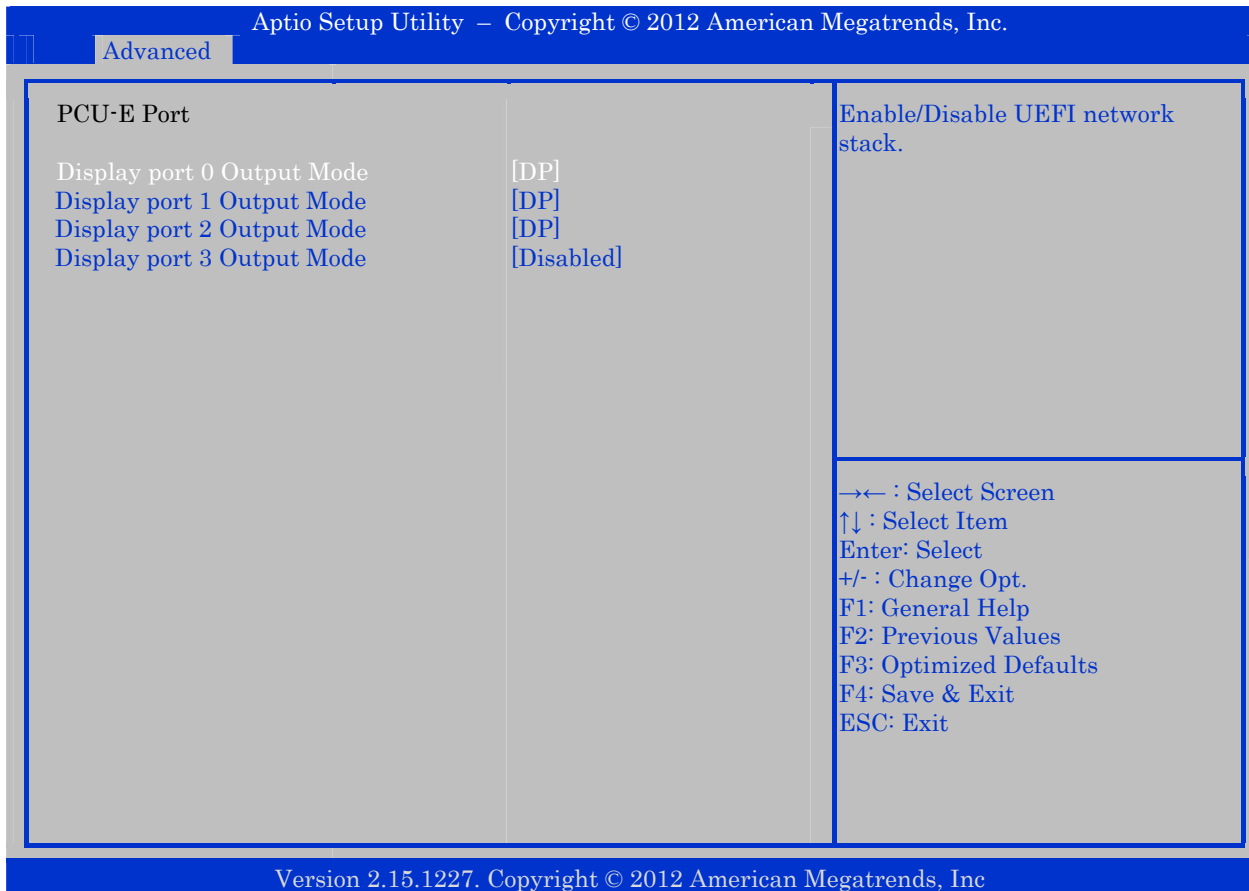

Function	Selection	Description
Display port # Output Mode (# = 0, 1, 2, 3)	DP eDP Single Link DVI-D Dual Link DVI-D HDMI Travis DP-to-VGA Travis DP-to-LVDS Nutmeg DP-to-VGA Single Link DVI-I CRT (VGA) LVDS Auto Detect Disabled Default Settings	NB PCIE Connect Type (Display device).

Defaults: Port 0, 1, 2 = DP and Port 3 = Disabled.

9.2.11 Network Stack

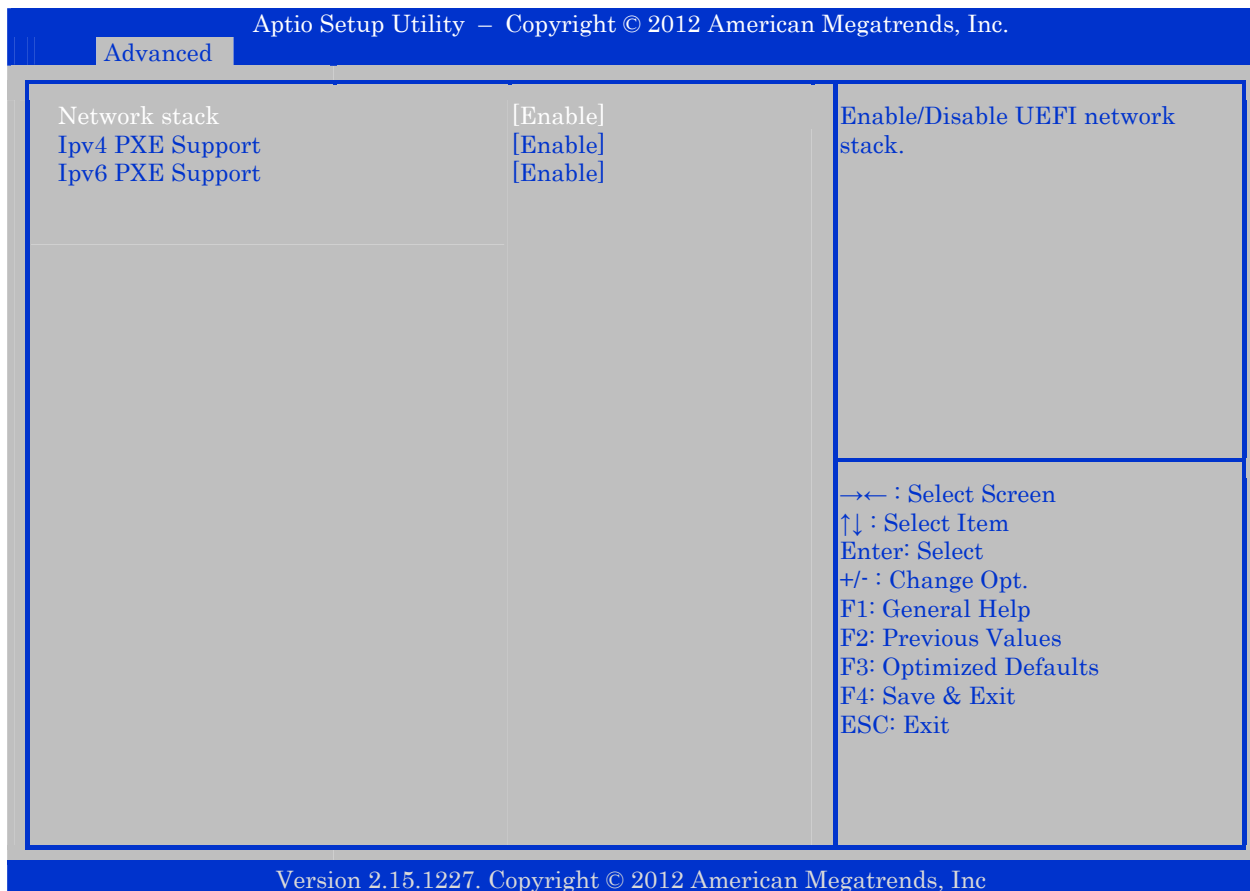

Function	Selection	Description
Network stack	Disable Enabled	Enable/Disable UEFI network stack.
Ipv4 PXE Support (Note1)	Enabled Disabled	Enable Ipv4 PXE Boot Support. If disabled IPV4 PXE boot option will not be created.
Ipv6 PXE Support (Note1)	Enabled Disabled	Enable Ipv6 PXE Boot Support. If disabled IPV6 PXE boot option will not be created.

Note1: Only if Network stack = Enabled.

9.3 Chipset

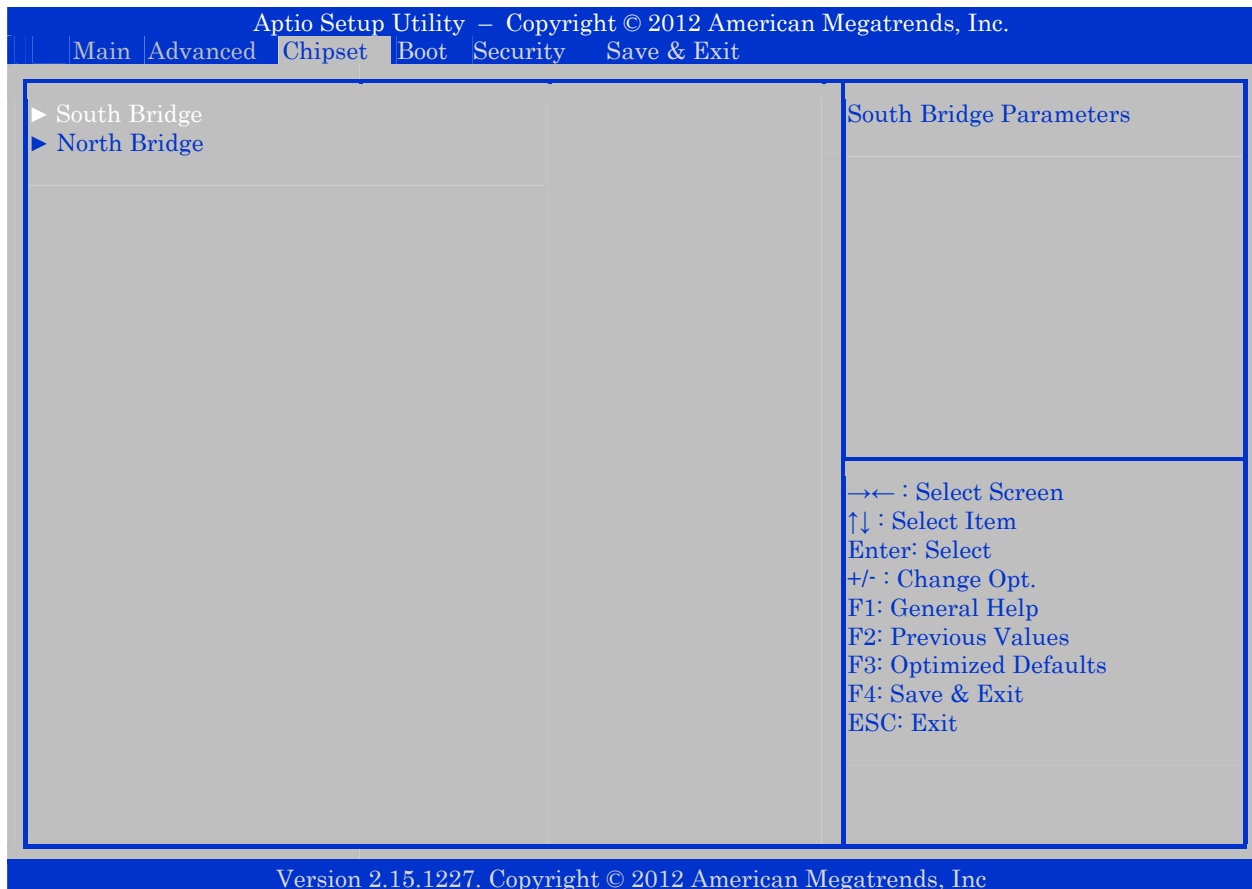

9.3.1 South Bridge

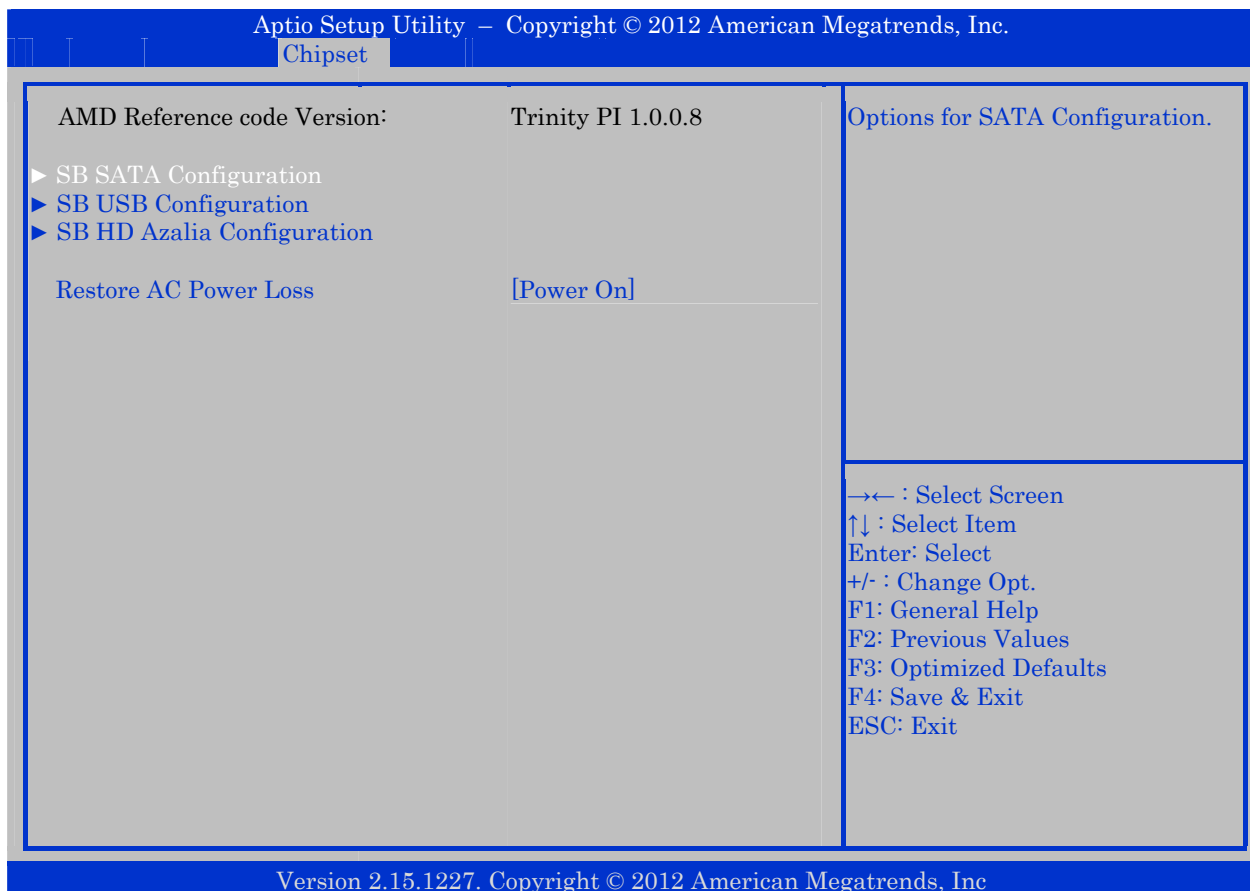

Please find description of the “SB SATA Configuration”, “SB USB Configuration” and “SB HD Azalia Configuration” on the following pages.

Function	Selection	Description
Restore AC Power Loss	Power Off Power On Last State	Select AC Power state when power is re-applied after a power failure.

SB SATA Configuration

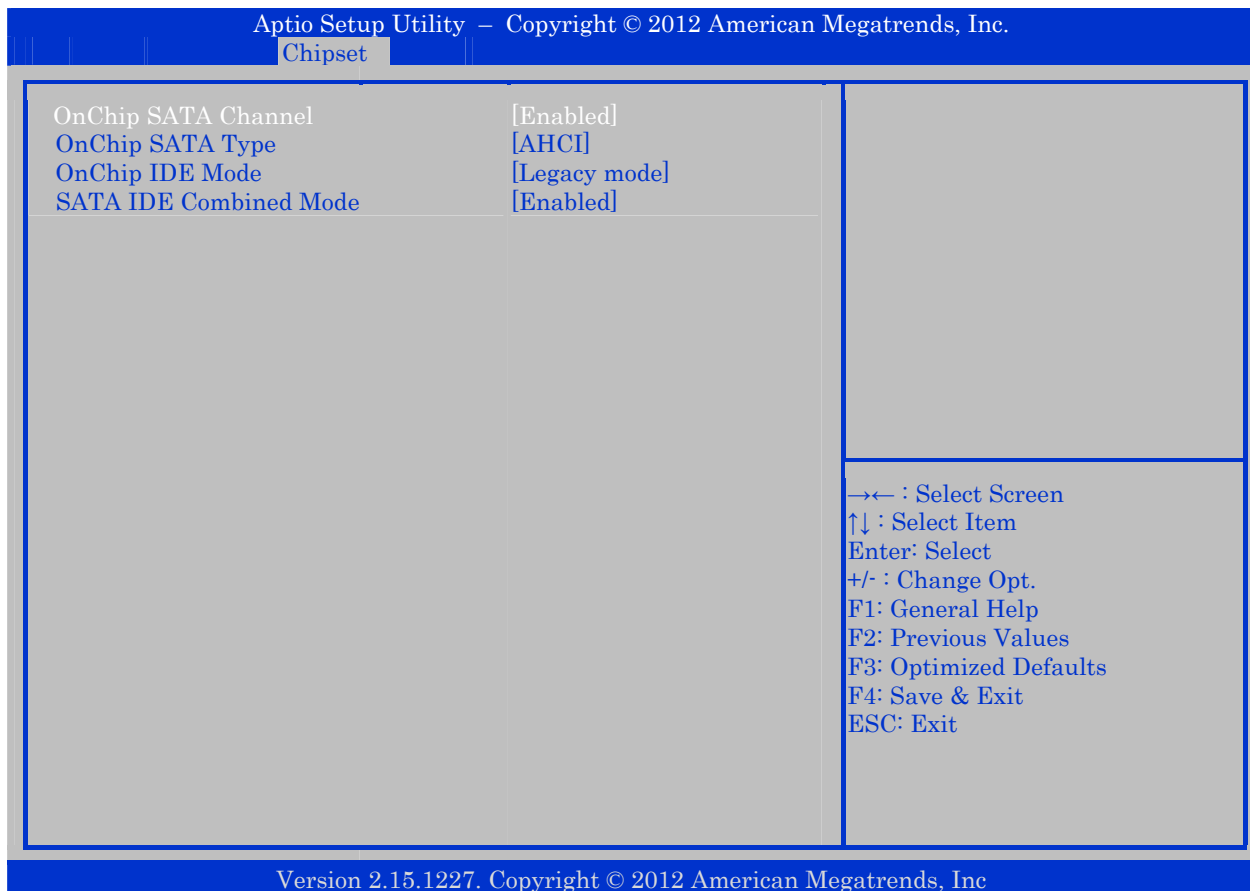

Function	Selection	Description
OnChip SATA Channel	Disabled Enabled	
OnChip SATA Type	Native IDE RAID AHCI Legacy IDE IDE ->AHCI AHCI as ID 7804 IDE->AHCI as ID 7804	Native IDE /n RAID Native IDE /n AHCI /n Legacy IDE /n IDE ->AHCI /n AHCI as ID 7804 /n IDE->AHCI as ID 7804
OnChip IDE mode	Legacy mode Native mode	
SATA IDE Combined Mode	Disabled Enabled	

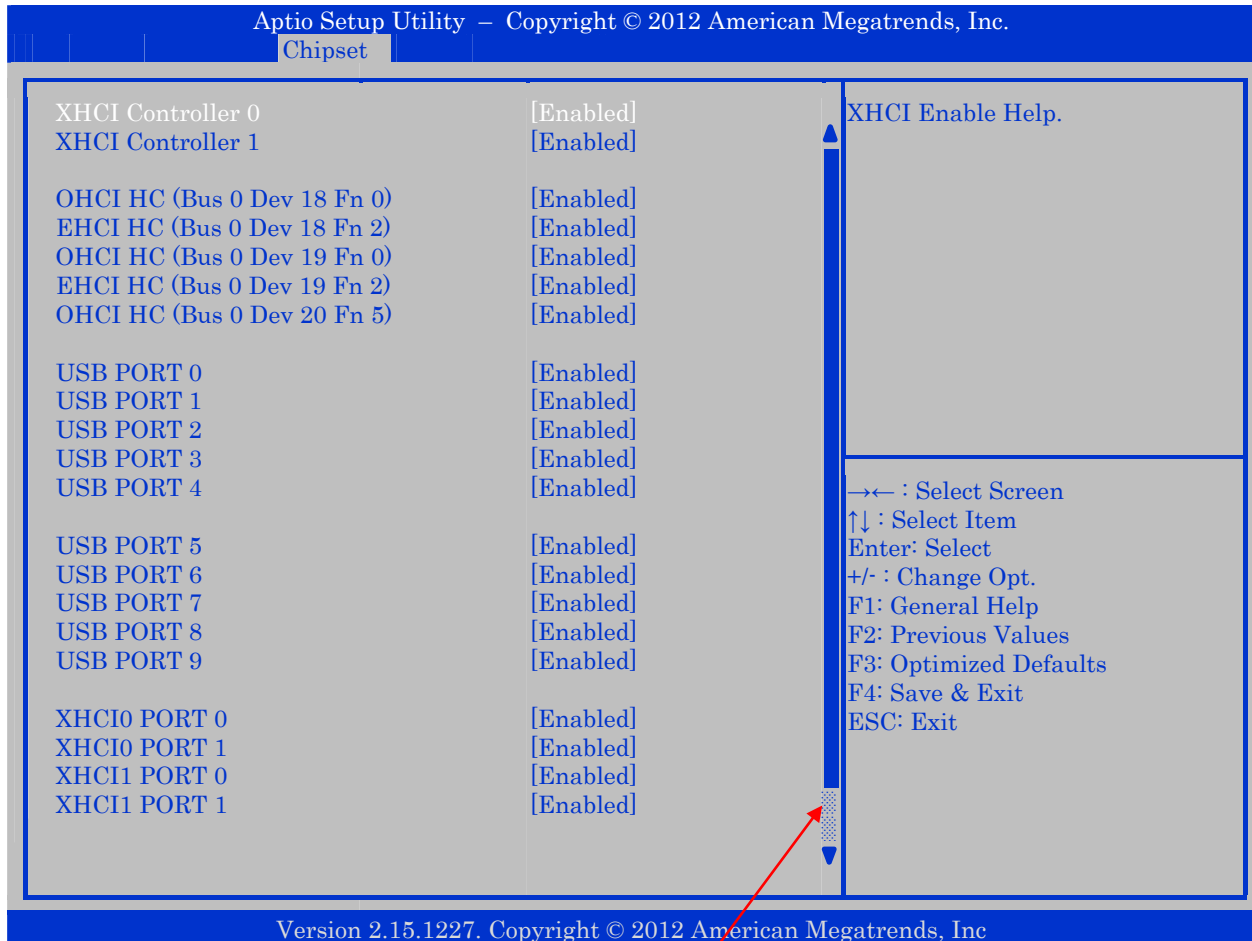

Scroll to see further settings.

SB USB Configuration

Function	Selection	Description
XHCI Controller 0	Disabled Enabled	XHCI Enable Help.
XHCI Controller 1	Disabled Enabled	XHCI Enable Help.
OHCI HC (Bus 0 Dev 18 Fn 0)	Disabled Enabled	
EHCI HC (Bus 0 Dev 18 Fn 2)	Disabled Enabled	
OHCI HC (Bus 0 Dev 19 Fn 0)	Disabled Enabled	
EHCI HC (Bus 0 Dev 19 Fn 2)	Disabled Enabled	
OHCI HC (Bus 0 Dev 20 Fn 5)	Disabled Enabled	
USB PORT 0 - 9	Disabled Enabled	
XHCI0 PORT 0	Disabled Enabled	
XHCI0 PORT 1	Disabled Enabled	
XHCI1 PORT 0	Disabled Enabled	
XHCI1 PORT 1	Disabled Enabled	
USB PORT FLO	Disabled Enabled	
USB PORT FL1	Disabled Enabled	

SB HD Azalia Configuration

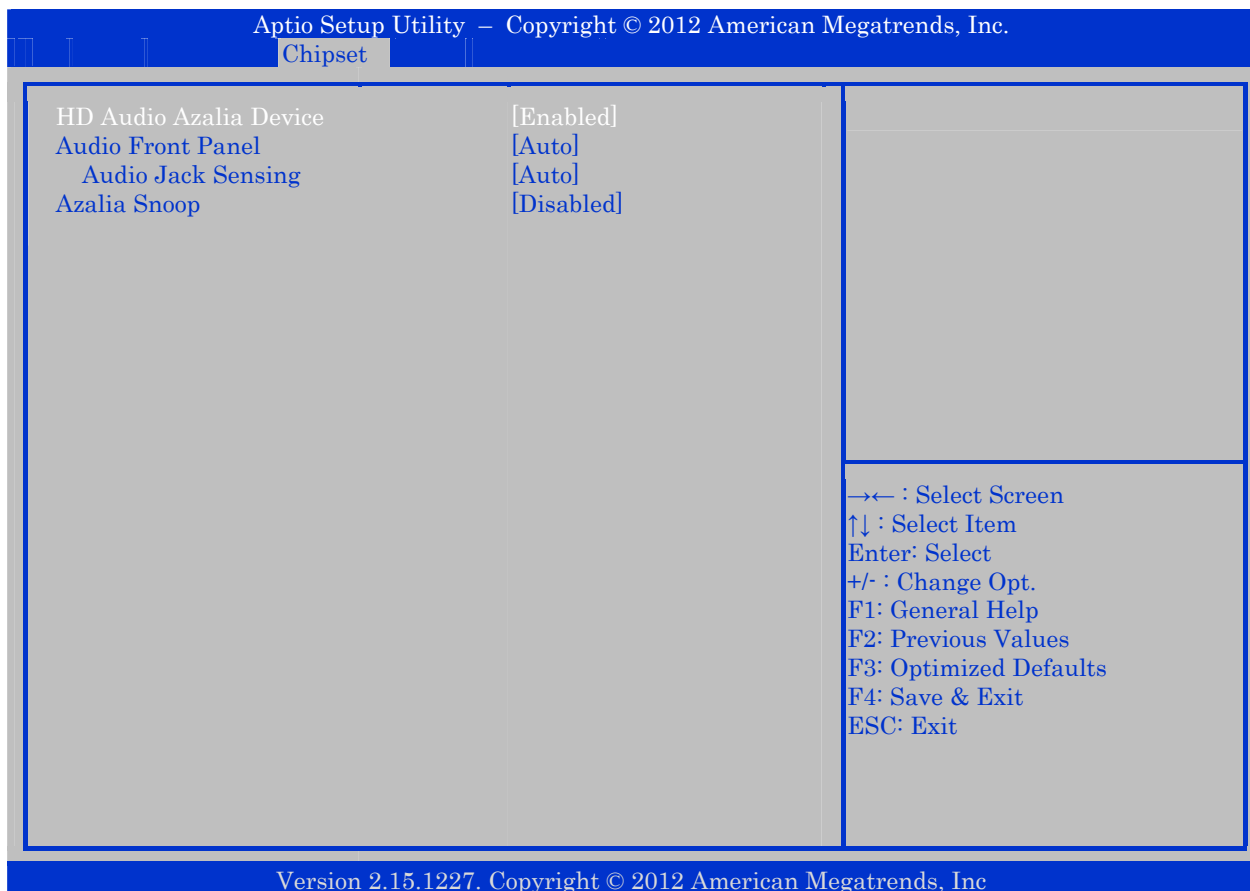

Function	Selection	Description
HD Audio Azalia Device	Auto Disabled Enabled	
Audio Front Panel	Auto Disabled Enabled	
Audio Jack Sensing	Disabled Auto	Auto: The insertions of audio jacks are auto determined. Disabled: Driver assumes that all jacks are inserted (useful when using the Audio pinrow)
Azalia Snoop	Disabled Enabled	Enable or disable internal HDMI codec for Azalia.

9.3.2 North Bridge

The screenshot displays the Aptio Setup Utility BIOS interface. At the top, a blue header bar contains the text "Aptio Setup Utility - Copyright © 2012 American Megatrends, Inc." and a "Chipset" tab. The main area is divided into two columns. The left column is titled "North Bridge Configuration" and contains a tree view with the following items: "Graphics Configuration", "Memory Information", "Total Memory: 8176 MB (DDR3)", "Memory Configuration", and "Socket 0 Information". The right column is titled "GFX Configuration." and is currently empty. At the bottom right of the main area, a list of navigation keys is provided: "→← : Select Screen", "↑↓ : Select Item", "Enter: Select", "+/- : Change Opt.", "F1: General Help", "F2: Previous Values", "F3: Optimized Defaults", "F4: Save & Exit", and "ESC: Exit". A blue footer bar at the bottom of the window contains the text "Version 2.15.1227. Copyright © 2012 American Megatrends, Inc".

Aptio Setup Utility - Copyright © 2012 American Megatrends, Inc.

Chipset

North Bridge Configuration

- ▶ Graphics Configuration
- Memory Information
- Total Memory: 8176 MB (DDR3)
- ▶ Memory Configuration
- ▶ Socket 0 Information

GFX Configuration.

→← : Select Screen
↑↓ : Select Item
Enter: Select
+/- : Change Opt.
F1: General Help
F2: Previous Values
F3: Optimized Defaults
F4: Save & Exit
ESC: Exit

Version 2.15.1227. Copyright © 2012 American Megatrends, Inc

Graphics Configuration

Aptio Setup Utility – Copyright © 2012 American Megatrends, Inc.

Chipset

GFX Configuration		Select Primary Video Device that BIOS will use as output.
Primary Video Device	[IGD Video]	
Brightness Control Mode Switch	[Control by Driver]	
Integrated Graphics	[Auto]	
PSPP Policy	[Performance]	

→← : Select Screen
 ↑↓ : Select Item
 Enter: Select
 +/- : Change Opt.
 F1: General Help
 F2: Previous Values
 F3: Optimized Defaults
 F4: Save & Exit
 ESC: Exit

Version 2.15.1227. Copyright © 2012 American Megatrends, Inc

Function	Selection	Description
Primary Video Device	IGD Video NB PCIe slot Video SB PCIe slot Video	Select Primary Video Device that BIOS will use as output.
Brightness Control Mode Switch	Control by VBIOS Control by Driver	Switch Brightness Control Mode between VBIOS/DRIVER.
Integrated Graphics	Auto Disabled Force	Enable Integrated Graphics controller.
PSPP Policy	Disabled Performance Balanced-High Balanced-Low Power Saving	PCIe speed power policy

Memory Configuration

Aptio Setup Utility – Copyright © 2012 American Megatrends, Inc.

Chipset

Memory Configuration		This option Allows User to select different Memory Clock. Default value is 800MHz.
Memory Clock	[Auto]	
Memory Hole Remapping	[Enabled]	
Bank Interleaveing	[Enabled]	
Channel Interleaving	[Enabled]	
Memory Clear	[Disabled]	

→← : Select Screen
 ↑↓ : Select Item
 Enter: Select
 +/- : Change Opt.
 F1: General Help
 F2: Previous Values
 F3: Optimized Defaults
 F4: Save & Exit
 ESC: Exit

Version 2.15.1227. Copyright © 2012 American Megatrends, Inc

Function	Selection	Description
Memory Clock	Auto 800MHz 1066MHz 1333MHz 1600MHz 1866MHz	This option Allows User to select different Memory Clock. Default value is 800MHz
Memory Hole Remapping	Disabled Enabled	Memory Hole Remapping.
Bank Interleaveing	Disabled Enabled	Bank Interleaveing
Channel Interleaving	Disabled Enabled	Channel Interleaving
Memory Clear	Disabled Enabled	Enable/Disable Memory Clear function.

Socket 0 Information

Aptio Setup Utility – Copyright © 2012 American Megatrends, Inc.

Chipset

Socket 0 Information

Starting Address: 0 KB
Ending Address: 8388607 KB

Dimm0: size=8192 MB, speed=800 MHz
Dimm1: Not Present

→← : Select Screen
↑↓ : Select Item
Enter: Select
+/- : Change Opt.
F1: General Help
F2: Previous Values
F3: Optimized Defaults
F4: Save & Exit
ESC: Exit

Version 2.15.1227. Copyright © 2012 American Megatrends, Inc

9.4 Boot

Aptio Setup Utility – Copyright © 2012 American Megatrends, Inc.					
Main	Advanced	Chipset	Boot	Security	Save & Exit
Boot Configuration					Number of seconds to wait for setup activation key. 65535 (0xFFFF) means indefinite waiting.
Setup Prompt Timeout		1			
Bootup NumLock State		[On]			
Quit Boot		[Disabled]			
Fast Boot		[Disabled]			
CSM16 Module Version			07.69		
GateA20 Active		[Upon Request]			
Option ROM Message		[Force BIOS]			
INT19 Trap Response		[Immediate]			
Boot Option Priorities					→← : Select Screen
Boot Option #1		[P0: Maxtor 6L120M0 ...]			↑↓ : Select Item
Boot Option #2		[UEFI: Built-in EFI ...]			Enter: Select
▶ CSM parameters					+/- : Change Opt.
					F1: General Help
					F2: Previous Values
					F3: Optimized Defaults
					F4: Save & Exit
					ESC: Exit
Version 2.15.1227. Copyright © 2012 American Megatrends, Inc					

Note: When pressing <F7> while booting it is possible manually to select boot device.

Function	Selection	Description
Setup Prompt Timeout	1, 2 - 65535 (Note)	Number of seconds to wait for setup activation key. 65535 (0xFFFF) means indefinite waiting.
Bootup NumLock State	On Off	Select the Keyboard Numlock state.
Quit Boot	Disabled Enabled	Enables or disables Quiet Boot option.
Fast Boot	Disabled Enabled	Enables or disables boot with initialization of a minimal set of devices required to launch active boot option. Has no effect for BBS boot options.
GateA20 Active	Upon Request Always	Upon Request: GA20 can be disabled using BIOS services. Always: do not allow disabling GA20; this option is useful when any RT code is executed above 1MB.
Option ROM Message	Force BIOS Keep Current	Set display mode for Option ROM.
INT19 Trap Response	Immediate Postponed	BIOS reaction on INT19 trapping by Option ROM. Immediate: execute the trap right away. Postponed: execute the trap during legacy boot.
Boot Option #1	(list of bootable devices)	Sets the system boot order.

Note: To enter number use digit keys and/or +/- keys.

9.4.1 CSM parameters

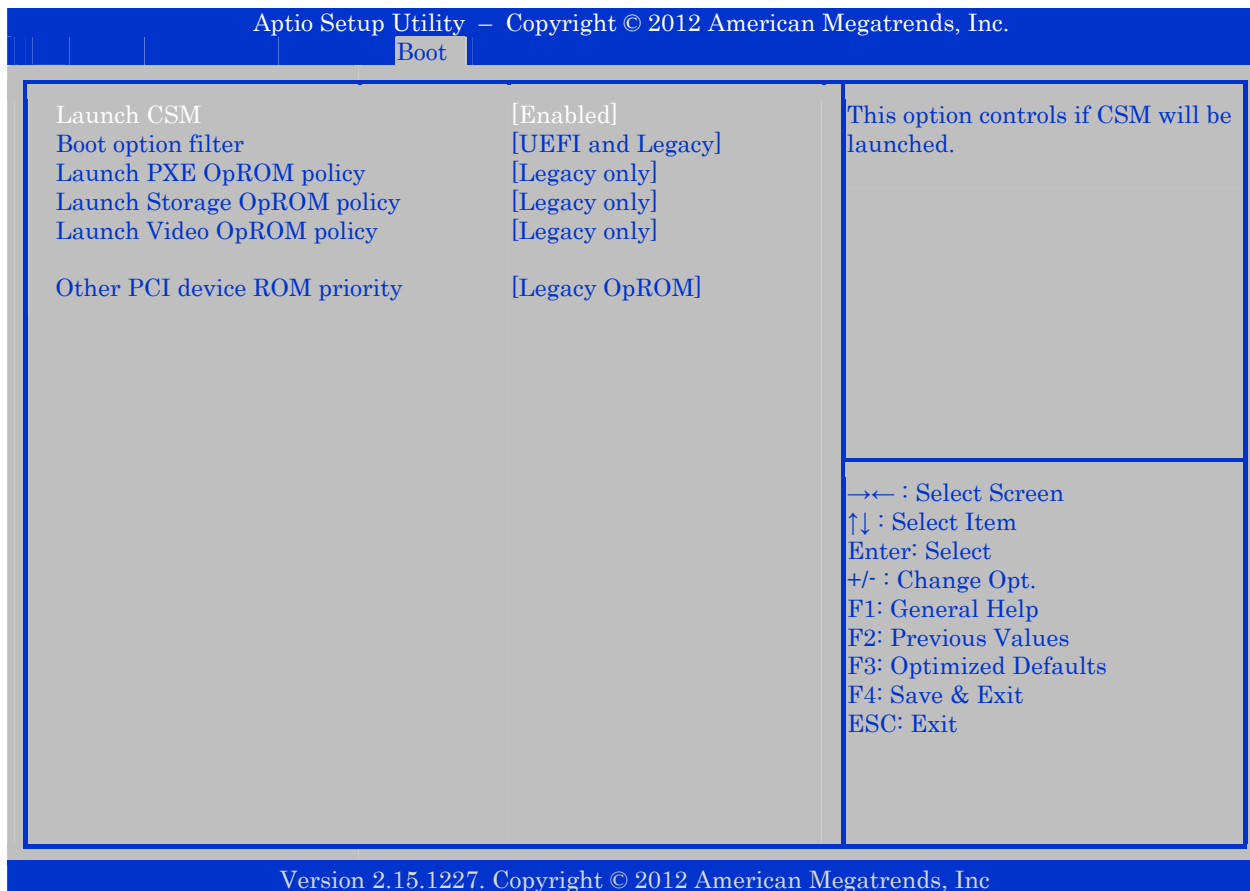

Function	Selection	Description
Launch CSM	Enabled Disabled	This option controls if CSM will be launched.
Boot option filter	UEFI and Legacy Legacy only UEFI only	This option controls what devices system can boot to.
Launch PXE OpROM policy	Do not launch UEFI only Legacy only	Controls the execution of UEFI and Legacy PXE OpROM.
Launch Storage OpROM policy	Do not launch UEFI only Legacy only	Controls the execution of UEFI and Legacy Storage OpROM.
Launch Video OpROM policy	Do not launch UEFI only Legacy only	Controls the execution of UEFI and Legacy Video OpROM.
Other PCI device ROM priority	UEFI OpROM Legacy OpROM	For PCI devices other than Network, Mass storage or Video defines which OpROM to launch.

9.5 Security

Aptio Setup Utility – Copyright © 2012 American Megatrends, Inc.

Main	Advanced	Chipset	Boot	Security	Save & Exit																
<p>Password Description</p> <p>If ONLY the Administrator's password is set, then this only limits access to Setup and is only asked for when entering Setup. If ONLY the User's password is set, then this is a power on password and must be entered to boot or enter Setup. In Setup the User will have Administrator rights. The password length must be in the following range:</p> <table style="width: 100%; border: none;"> <tr> <td style="padding-right: 20px;">Minimum length</td> <td style="text-align: right;">3</td> </tr> <tr> <td>Maximum length</td> <td style="text-align: right;">20</td> </tr> </table>					Minimum length	3	Maximum length	20	<p style="color: #0056b3;">Set Administrator Password</p>												
Minimum length	3																				
Maximum length	20																				
<table style="width: 100%; border: none;"> <tr> <td style="width: 40%; padding-right: 10px;">Administrator Password</td> <td></td> </tr> <tr> <td>User Password</td> <td></td> </tr> <tr> <td colspan="2" style="padding-top: 10px;">System Mode state</td> <td style="text-align: right;">Setup</td> </tr> <tr> <td colspan="2">Secure Boot state</td> <td style="text-align: right;">Disabled</td> </tr> <tr> <td colspan="2" style="padding-top: 10px;">Secure Boot</td> <td style="text-align: right;">[Enabled]</td> </tr> <tr> <td colspan="2">Secure Boot Mode</td> <td style="text-align: right;">[Standard]</td> </tr> </table>					Administrator Password		User Password		System Mode state		Setup	Secure Boot state		Disabled	Secure Boot		[Enabled]	Secure Boot Mode		[Standard]	<p>→← : Select Screen ↑↓ : Select Item Enter: Select +/- : Change Opt. F1: General Help F2: Previous Values F3: Optimized Defaults F4: Save & Exit ESC: Exit</p>
Administrator Password																					
User Password																					
System Mode state		Setup																			
Secure Boot state		Disabled																			
Secure Boot		[Enabled]																			
Secure Boot Mode		[Standard]																			

Version 2.15.1227. Copyright © 2012 American Megatrends, Inc

Function	Selection	Description
Administrator Password	(See Password description above)	Set Administrator Password
User Password	(See Password description above)	Set User Password
Secure Boot	Disabled Enabled	Secure Boot flow control. Secure Boot is possible only if System runs in User Mode.
Secure Boot Mode	Standard Custom	Secure Boot mode selector. Standard: fixed Secure boot policy. Custom: changeable Image Execution policy and Secure Boot Key databases.

9.6 Save & Exit

This Menu is special; having no “selections” for each function, or in other words, the function is the same as the selection.

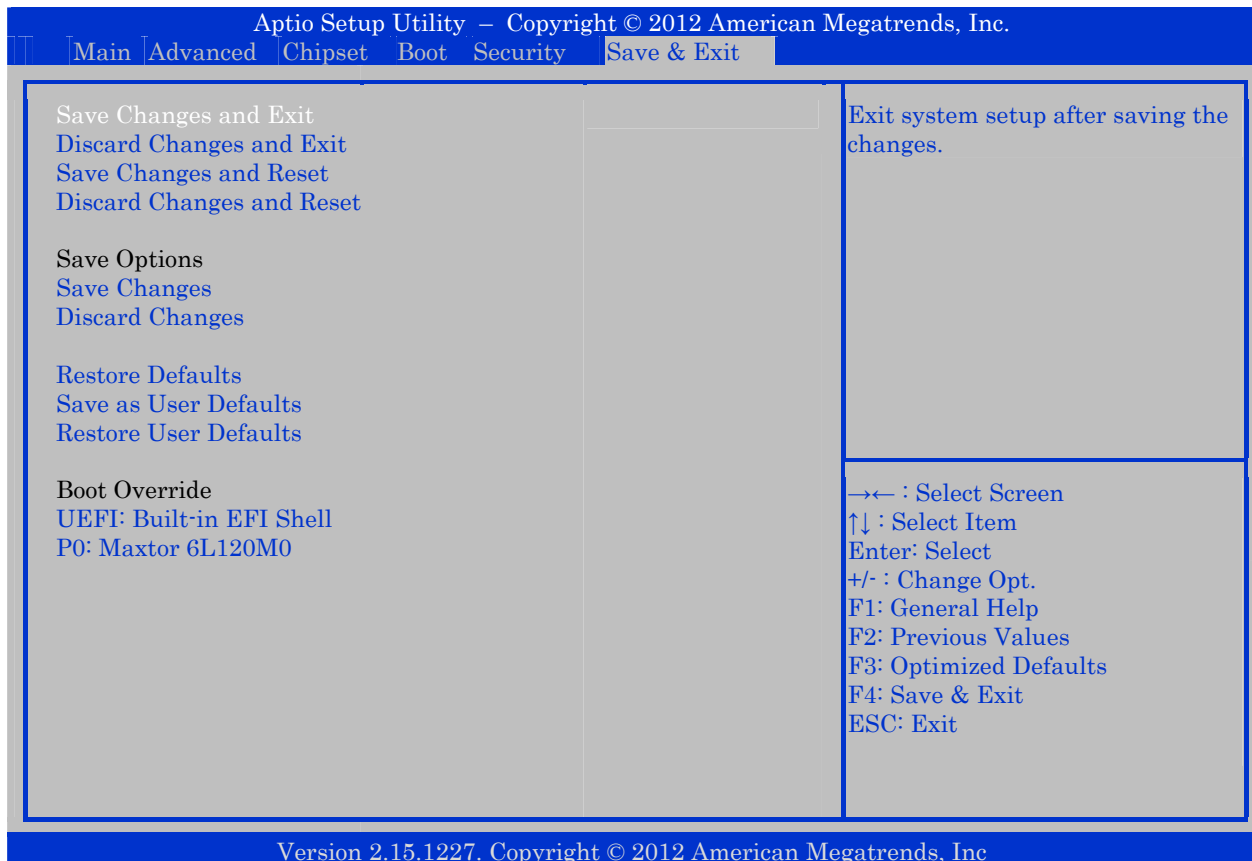

Note: When pressing <F7> while booting it is possible manually to select boot device.

Function	Description
Save Changes and Exit	Exit system setup after saving the changes.
Discard Changes and Exit	Exit system setup without saving any changes.
Save Changes and Reset	Reset the system after saving the changes.
Discard Changes and Reset	Reset the system without saving any changes.
Save Changes	Save Changes done so far to any of the setup options.
Discard Changes	Discard Changes done so far to any of the setup options.
Restore Defaults	Restore/Load Default values for all the setup options.
Save as User Defaults	Save the Changes done so far as User Defaults.
Restore User Defaults	Restore the User Defaults to all the setup options.
(possible list of boot devices)	Selection table of bootable devices. When selected system will boot on selected device.

10 AMI BIOS Beep Codes

Boot Block Beep Codes:

Beeps	Description
1	Insert diskette in floppy drive A:
2	'AMIBOOT.ROM' file not found in root directory of diskette in A:
3	Base Memory error
4	Flash Programming successful
5	Floppy read error
6	Keyboard controller BAT command failed
7	No Flash EPROM detected
8	Floppy controller failure
9	Boot Block BIOS checksum error
10	Flash Erase error
11	Flash Program error
12	'AMIBOOT.ROM' file size error
13	BIOS ROM image mismatch (file layout does not match image present in flash device)

POST BIOS Beep Codes:

Beeps	Description
1	Memory refresh timer error.
2	Parity error in base memory (first 64KB block)
3	Base memory read/write test error
4	Motherboard timer not operational
5	Processor error
6	8042 Gate A20 test error (cannot switch to protected mode)
7	General exception error (processor exception interrupt error)
8	Display memory error (system video adapter)
9	AMIBIOS ROM checksum error
10	CMOS shutdown register read/write error
11	Cache memory test failed

Troubleshooting POST BIOS Beep Codes:

Beeps	Troubleshooting Action
1, 2 or 3	Reset the memory, or replace with known good modules.
4-7, 9-11	Fatal error indicating a serious problem with the system. Consult your system manufacturer. Before declaring the motherboard beyond "all hope", eliminate the possibility of interference due to a malfunctioning add-in card. Remove all expansion cards, except the video adapter. <ul style="list-style-type: none"> If beep codes are generated when all other expansion cards are absent, consult your system manufacturer's technical support. If beep codes are not generated when all other expansion cards are absent, one of the add-in cards is causing the malfunction. Insert the cards back into the system one at a time until the problem happens again. This will reveal the malfunctioning card.
8	If the system video adapter is an add-in card, replace or reset the video adapter. If the video adapter is an integrated part of the system board, the board may be faulty.

Appendix: Mating Connectors

The Mating connectors / Cables are connectors or cable kits which are fitting the On-board connector.

Connector		Onboard Connectors		Mating Connectors	
		Manufacturer	P/N	Manufacturer	P/N
DisplayPort	J3/J4/J43	Foxconn	3VD11203-H7AB-4H		
USB10/USB11/USB12/USB13	J14/J15	Lotes	ABA-USB-104-K01		
ETH1/ETH2	J8	Ude	RMT-123AGF1F		
USB6/USB7/USB8/USB9	J20	Foxconn	UB11123-Q8DF-4F		
Audio stack	J40	Lotes	ABA-JAK-028-K03		
Power (External)	J28	Molex	0430450402	Molex Kontron	43025-0400 1052-5814 (Kit)
Power (Internal)	J19	Lotes	ABA-POW-003-K02	Molex	39-01-2045
12V-SB-In	J31	Molex	22-23-2021	Molex	22-01-2025
Audio Header	J41	Molex	87832-2620	Molex Kontron	51110-2651 821043 (kit)
Power Out	J18	Molex	22-23-2041	Molex Kontron	22-01-2045 1027-3669 (Kit)
USB4/USB5	J16	Foxconn	HS1105F-RNP9		
SPI	J21	Pinrex	512-90-10GBE5		
COM1/COM2	J22/J23	Pinrex	512-90-10GBE5	Molex Kontron	90635-1103 821017 (kit)
LPC	J29	Foxconn	HC11101-P0		
Frontpanel	J5	Wieson	G2120HT0038-016	Molex Kontron	90635-1243 821042 (kit)
CPU Fan/System Fan	J24/J25	Tyco	1470947-1	Molex	47054-1000
Feature	J26	Pinrex	52C-90-44GB00	Don Connex	A05c-44-B-G-A-1-G
		Foxconn	HS5422F	Kontron	1052-5885 (kit)
KBD/MSE	J27	Molex	22-23-2061	Molex Kontron	22-01-2065 1053-2384 (kit)

Cable & Driver Kit KTA70M/KTA75 (PN 826600-R11) contains:

- 2x PN 821017 Cable, COM, 2.54mm, 100mm
- 1x PN 1052-5885 Cable, Feature 44pol 1 to1, 300mm
- 1x PN 1053-2384 Bracket Cable 6-Pin to PS2-Kbd-Mse
- 1x PN 821042 Cable, Front Panel Open-End
- 1x PN 821043 Cable, Audio Open-End
- 6x PN 821035 Cable, SATA, 500mm
- 1x PN 1052-5814 Cable, ATX Power for KTA70M
- 1x PN 1027-3669 Cable Power Out
- 1x PN 821401 Cable+Bracket, USB, 10poled
- 1x PN 1052-5818 SW,Man&Driver CD,KTA70M/KTA75

Appendix: OS Setup

Use the Setup.exe files for all relevant drivers. The drivers can be found on KTA7x Driver CD or they can be downloaded from the homepage <http://www.kontron.com/>

For some OS like Win7 when installing OS via USB DVD, USB Keyboard/Mouse, please connect the USB DVD, USB Keyboard/Mouse to USB2.0 ports only or disable USB3.0 in BIOS.

Corporate Offices

Europe, Middle East & Africa

Oskar-von-Miller-Str. 1
85386 Eching/Munich
Germany
Tel.: +49 (0) 8165/ 77 777
Fax: +49 (0) 8165/ 77 219
info@kontron.com

North America

14118 Stowe Drive
Poway, CA 92064-7147
USA
Tel.: +1 888 294 4558
Fax: +1 858 677 0898
info@us.kontron.com

Asia Pacific

17 Building,Block #1,ABP
188 Southern West 4th Ring Road
Beijing 100070, P.R.China
Tel.: + 86 10 63751188
Fax: + 86 10 83682438
info@kontron.cn