

» Kontron User's Guide «

Advanced TCA®

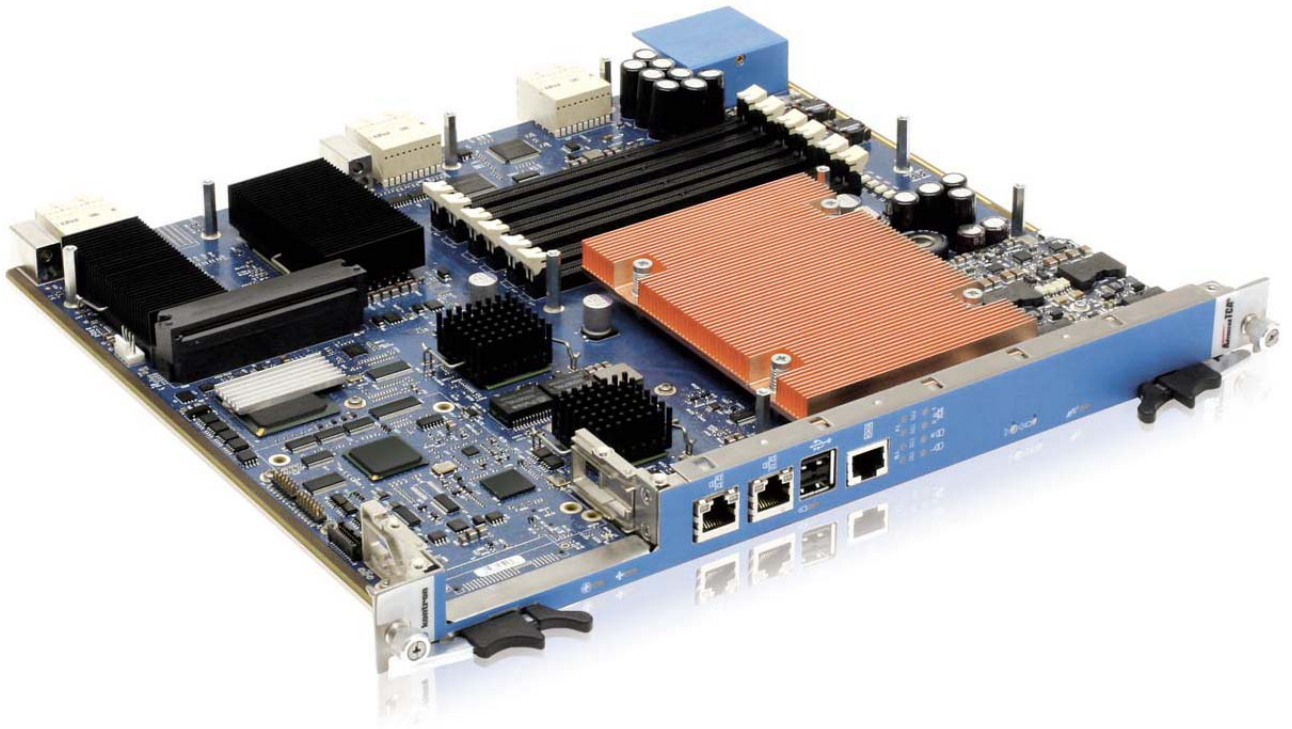

AT8050

Document Revision 1.10
January 2016

Revision History

Rev. Index	Brief Description of Changes	Date of Issue
1.0	First Release	April 2009
1.1	Second Release	November 2009
1.2	Third Release	April 2010
1.3	Fourth Release	September 2011
1.4	Fifth Release	October 2013
1.5	Sixth Release	January 2014
1.6	Sel size corrected	May 2014
1.7	Change declaration of FCC Compliance statements from Class B to Class A.	September 2014
1.8	OS Compatibility update	July 2015
1.9	Watchdog timer sub-menu update	July 2015
1.10	OS Compatibility update	January 2016

Customer Service

Contact Information:

Kontron America, Inc.

14118 Stowe Drive
Poway, CA 92064-7147
USA
Tel: +1 888 294 4558
Fax: +1 858 677 0898
E-mail: support@us.kontron.com

Kontron Europe GmbH

Lise-Meitner-Str. 3-5
86156 Augsburg
Germany
Tel.: +800-KONTRONAG
Tel.: +49 821 4086 888
E-mail: support@kontron.com

Visit our site at: www.kontron.com

© 2016 Kontron, an International Corporation. All rights reserved.

The information in this user's guide is provided for reference only. Kontron does not assume any liability arising out of the application or use of the information or products described herein. This user's guide may contain or reference information and products protected by copyrights or patents and does not convey any license under the patent rights of Kontron, nor the rights of others.

Kontron is a registered trademark of Kontron. All trademarks, registered trademarks, and trade names used in this user's guide are the property of their respective owners. All rights reserved. Printed in Canada. This user's guide contains information proprietary to Kontron. Customers may reprint and use this user's guide in

other publications. Customers may alter this user's guide and publish it only after they remove the Kontron name, cover, and logo.

Kontron reserves the right to make changes without notice in product or component design as warranted by evolution in user needs or progress in engineering or manufacturing technology. Changes that affect the operation of the unit will be documented in the next revision of this user's guide.

Table of Contents

<i>Safety Instructions</i>	<i>x</i>
Before You Begin	x
Preventing Electrostatic Discharge	xi
<i>Preface</i>	<i>xii</i>
How to Use This Guide	xii
Customer Comments	xiii
Advisory Conventions	xiii
Unpacking	xiv
Powering Up the System	xiv
Adapter Cables	xiv
Storing Boards	xiv
Regulatory Compliance Statements	xv
Limited Warranty	xvi
1. Product Description	2
1.1 Product Overview	2
1.2 What's Included	2
1.3 Board Specifications	3
1.4 Compliance	5
1.5 Hot-Plug Capability	5
1.6 Interfacing with the Environment	5
1.6.1 RTM (rear transition module)	5
1.6.2 Advanced Mezzanine Card	7
2. Board Features	9
2.1 Block Diagram	9
2.2 System Core	10
2.2.1 Processor	10
2.2.2 Intel IOH 36D	10
2.2.3 ICH10R	10
2.3 USB 2.0 Interfaces	11
2.4 USB Flash Module	12

2.5	Serial ATA/Serial Attached SCSI	12
2.5.1	Serial Attached SCSI (LSISAS1064e is PCI-e rev 1.1)	12
2.5.2	Serial ATA (ICH10R)	13
2.6	Update Channel	13
2.7	Real Time Clock & NVRAM	13
2.8	Redundant BIOS Flash	13
2.9	Ethernet Interfaces	14
2.9.1	Fabric Interface	14
2.9.2	Base Interface	15
2.9.3	Management Interface	15
2.9.4	Ethernet Interfaces Configuration	16
2.10	Serial Interfaces	24
2.11	AMC Mezzanine	24
2.12	FPGA	26
2.13	Telecom Clock Option	26
2.14	Redundant IPMC Firmware & BootBlock	26
2.15	LEDs Description	27
2.15.1	Hot Swap LED (LED0)	27
2.15.2	Out Of Service (LED1)	27
2.15.3	Healthy LED (LED2)	27
3.	<i>Installing the Board</i>	30
3.1	Setting Jumpers	30
3.1.1	Jumper Description	30
3.1.2	Setting Jumper & Locations	30
3.2	Processor	31
3.3	Memory	31
3.3.1	Memory List and Characteristics	32
3.3.2	Installing Memory	33
3.4	Onboard Connectors and Headers	34
3.5	Board Hot Swap and Installation	35
3.5.1	Installing the Board in the Chassis	35
3.5.2	Removing the Board	35
3.5.3	Installing an AMC	36
3.5.4	Removing an AMC	36
3.5.5	Installing the RTM8050	36
3.5.6	Removing the RTM8050	36

4.	<i>Hardware Management</i>	38
4.1	Hardware Management Overview	38
4.2	Hardware Management Functionality	38
4.2.1	IPMC specific features	38
4.2.2	Sensors	39
4.3	IPMC	40
4.3.1	Supported commands	40
4.3.2	Sensor Data Records	48
4.3.3	FRU Information	58
4.3.4	Clock E-Keying Information	75
4.3.5	Component Upgrade Support	82
5.	<i>Software Setup</i>	84
5.1	AMI BIOS Setup Program	84
5.1.1	Accessing the BIOS Setup Utility	84
5.1.2	Menu Bar	86
5.1.3	Main Menu	87
5.1.4	Advanced Menu	88
5.1.5	Security Menu	98
5.1.6	Boot Menu	99
5.1.7	System Management Menu	104
5.1.8	Exit Menu	113
5.2	Boot Utilities	113
5.2.1	Entering BIOS Setup Menu	113
5.2.2	Boot Menu POP-UP	113
5.2.3	SAS Option ROM	113
5.2.4	BOOT Menu POP-UP	114
5.3	Console Redirection (VT100 Mode)	114
5.3.1	Requirements	114
5.3.2	ANSI and VT100 Keystroke Mapping	114
5.3.3	VT-UTF8 Keystroke Mapping	115
6.	<i>Thermal Considerations</i>	117
6.1	Thermal Monitoring	117
6.1.1	Heat Sinks	117
6.1.2	Temperature Sensors	117
6.1.3	Airflow blockers	119
6.1.4	System Airflow	119
6.1.5	Thermal Profile	120

A.	<i>Memory & I/O Maps</i>	<i>A-1</i>
A.1	Memory Mapping	A-1
A.2	Kontron I/O Mapping	A-2
A.3	PCI IDSEL and Device Numbers	A-3
A.4	Telco Clock	A-5
B.	<i>Connector Pinouts</i>	<i>B-1</i>
B.1	Connectors and Headers Summary	B-1
B.2	Post Codes (J2)	B-1
B.3	AMC B1 (J5)	B-2
B.4	Ethernet (J8 & J9)	B-3
B.5	USB Port (J10)	B-3
B.6	Serial Port, COM1 (J12)	B-3
B.7	Synchronisation Clocks, Update Channel (J20)	B-4
B.8	USB Flash Drive (J22)	B-4
B.9	Base Interface & Fabric Interface (J23)	B-5
B.10	RTM Connector (J30)	B-6
B.11	Power (P10)	B-7
C.	<i>BIOS Setup Error Codes</i>	<i>C-1</i>
C.1	Bootblock Initialization Code Checkpoints	C-1
C.2	POST Code Checkpoints	C-2
C.3	DIM Code Checkpoints	C-4
C.4	Memory Initialization ERROR Code	C-5
D.	<i>Software Update</i>	<i>D-1</i>
E.	<i>Getting Help</i>	<i>E-1</i>
E.1	Returning Defective Merchandise	E-1
E.2	When Returning a Unit	E-2
F.	<i>Glossary</i>	<i>F-1</i>

List of Figures

Figure 2-1: Block Diagram	9
Figure 2-2: Available Ethernet Interfaces Configurations	16
Figure 2-3: 10GbE and Management to Front Panel	17
Figure 2-4: 10GbE and Management to AMC	18
Figure 2-5: 10GbE and Management to RTM	19
Figure 2-6: AMC to Fabric Interface and Management to Front Panel	20
Figure 2-7: AMC to Fabric Interface and Management to AMC	21
Figure 2-8: AMC to Fabric Interface and Management to RTM	22
Figure 2-9: Management to Fabric Interface	23
Figure 2-10: Faceplate LEDs	28
Figure 3-1: Jumper Settings and Locations	30
Figure 3-2: Onboard Connectors and Headers Locations	34
Figure 6-1: Pressure Curve in Imperial	119
Figure 6-2: Pressure Curve in Metric	120
Figure 6-3: CPU Thermal Profile	120

List of Tables

Table 1-1	Board Specifications	3
Table 2-1	USB Connector Pinout	11
Table 2-2	Serial Interface connector Pinout	24
Table 2-3	Faceplate LEDs	27
Table 3-1	Jumper Description	30
Table 3-2	Approved Memory List	32
Table 3-3	Onboard Connectors and Headers	34
Table 4-1	IPM Device Supported Commands for IPMC	40
Table 4-2	Watchdog Timer Supported Commands for IPMC	40
Table 4-3	Device Messaging Supported Commands for IPMC	40
Table 4-4	Chassis Device Supported Commands for IPMC	42
Table 4-5	Event Supported Commands for IPMC	42
Table 4-6	PEF and Alerting Supported Commands for IPMC	43
Table 4-7	Sensor Device Supported Commands for IPMC	43
Table 4-8	FRU Device Supported Commands for IPMC	44
Table 4-9	SDR Device Supported Commands for IPMC	44
Table 4-10	SEL Device Supported Commands for IPMC	44
Table 4-11	LAN Device Supported Commands for IPMC	45
Table 4-12	Serial/Modem Device Supported Commands for IPMC	45
Table 4-13	SOL Commands	46
Table 4-14	PICMG 3.0 Commands for IPMC	46
Table 4-15	AMC.0 Carrier Commands for IPMC	47
Table 4-16	HPM Commands	48
Table 4-17	IPMC Sensors	49
Table 4-18	IPMC Health Indicator Sensor Aggregation Table	56
Table 4-19	Board Information Area	58
Table 4-20	Product Information Area	59
Table 4-21	E-Keying capabilities of the board	60
Table 4-22	AMC Carrier Activation and Carrier Information Table	61
Table 4-23	Carrier AMC.0	62
Table 4-24	Mapping between the devices and the corresponding Ids	62
Table 4-25	Record's content	62
Table 4-26	AMC connectivity details for "Intel IOH PCI-Express Root Complex Port 3"	66
Table 4-27	AMC connectivity details for "Intel IOH PCI-Express Root Complex Port 8"	68

Table 4-28	AMC connectivity details for "Intel ICH10 SATA Controller"	70
Table 4-29	AMC connectivity details for "Intel 82576EB NC (front/rear)"	71
Table 4-30	AMC connectivity details for "Onboard Fabric Channel 1 Switch"	72
Table 4-31	AMC connectivity details for "Onboard Fabric Channel 2 Switch"	73
Table 4-32	AMC connectivity details for "FPGA Based UART"	74
Table 4-33	Clock resources id assignment mapping	75
Table 4-34	Carrier Clock Point-to-Point Connectivity Record Table	75
Table 4-35	PCIe Clock Generator	77
Table 4-36	Onboard Clock Multiplexer.	78
Table 4-37	HPM component IDs	82
Table 4-38	non-HPM components	82
Table 6-1	Temperature Sensors Thresholds.	118
Table 6-2	Pressure curve AT8050 with AMC Filler.	119

Safety Instructions

Before You Begin

Before handling the board, read the instructions and safety guidelines on the following pages to prevent damage to the product and to ensure your own personal safety. Refer to the "Advisories" section in the Preface for advisory conventions used in this user's guide, including the distinction between Warnings, Cautions, Important Notes, and Notes.

- Always use caution when handling/operating the computer. Only qualified, experienced, authorized electronics service personnel should access the interior of the computer. The power supplies produce high voltages and energy hazards, which can cause bodily harm.
- Use extreme caution when installing or removing components. Refer to the installation instructions in this user's guide for precautions and procedures. If you have any questions, please contact Kontron Technical Support



WARNING

High voltages are present inside the chassis when the unit's power cord is plugged into an electrical outlet. Turn off system power, turn off the power supply, and then disconnect the power cord from its source before removing the chassis cover. Turning off the system power switch does not remove power to components.



Preventing Electrostatic Discharge

Static electricity can harm system boards. Perform service at an ESD workstation and follow proper ESD procedure to reduce the risk of damage to components. Kontron strongly encourages you to follow proper ESD procedure, which can include wrist straps and smocks, when servicing equipment.

Take the following steps to prevent damage from electrostatic discharge (ESD):

- When unpacking a static-sensitive component from its shipping carton, do not remove the component's antistatic packing material until you are ready to install the component in a computer. Just before unwrapping the antistatic packaging, be sure you are at an ESD workstation or grounded. This will discharge any static electricity that may have built up in your body.
- When transporting a sensitive component, first place it in an antistatic container or packaging.
- Handle all sensitive components at an ESD workstation. If possible, use antistatic floor pads and workbench pads.
- Handle components and boards with care. Don't touch the components or contacts on a board. Hold a board by its edges or by its metal mounting bracket.
- Do not handle or store system boards near strong electrostatic, electromagnetic, magnetic, or radioactive fields.
- When you want to remove the protective foil (if present), make sure you are properly grounded and that you touch a metallic part of the board.



CAUTION

Removing the protective foil from the top and bottom cover might create static. When you remove those protections, make sure you follow the proper ESD procedure.



Preface

How to Use This Guide

This user's guide is designed to be used as step-by-step instructions for installation, and as a reference for operation, troubleshooting, and upgrades.

For the circuits, descriptions and tables indicated, Kontron assumes no responsibility as far as patents or other rights of third parties are concerned.

The following is a summary of chapter contents:











- Chapter 1, Product Description
- Chapter 2, Board Features
- Chapter 3, Installing the board
- Chapter 4, Hardware Management
- Chapter 5, Software Setup
- Chapter 6, Thermal Considerations
- Appendix A, Memory & I/O Maps
- Appendix B, Connector Pinout
- Appendix C, BIOS Setup Error Codes
- Appendix D, Software Update
- Appendix E, Getting Help
- Appendix F, Glossary

Customer Comments

If you have any difficulties using this user's guide, discover an error, or just want to provide some feedback, please send a message to: Tech.Writer@ca.kontron.com. Detail any errors you find. We will correct the errors or problems as soon as possible and post the revised user's guide on our Web site. Thank you.

Advisory Conventions

Seven types of advisories are used throughout the user guides to provide helpful information or to alert you to the potential for hardware damage or personal injury. They are Note, Signal Paths, Jumpers Settings, BIOS Settings, Software Usage, Cautions, and Warnings. The following is an example of each type of advisory. Use caution when servicing electrical components.

	Note: Indicate information that is important for you to know.	
	Signal Path: Indicate the places where you can find the signal on the board.	
	Jumper Settings: Indicate the jumpers that are related to this sections.	
	BIOS Settings: Indicate where you can set this option in the BIOS.	
	Software Usage: Indicates how you can access this feature through software.	
	CAUTION	
	WARNING	
	ESD Sensitive Device: This symbol and title inform that electronic boards and their components are sensitive to static electricity. Therefore, care must be taken during all handling operations and inspections of this product, in order to ensure product integrity at all times. Please read also the section "Special Handling and Unpacking Instructions".	
	CE Conformity: This symbol indicates that the product described in this manual is in compliance with all applied CE standards. Please refer also to the section "Regulatory Compliance Statements" in this manual.	

Disclaimer: We have tried to identify all situations that may pose a warning or a caution condition in this user's guide. However, Kontron does not claim to have covered all situations that might require the use of a Caution or a Warning.

Unpacking

Follow these recommendations while unpacking:

- Remove all items from the box. If any items listed on the purchase order are missing, notify Kontron customer service immediately.
- Inspect the product for damage. If there is damage, notify Kontron customer service immediately.
- Save the box and packing material for possible future shipment.

Powering Up the System

Before any installation or setup, ensure that the board is unplugged from power sources or subsystems.

If you encounter a problem, verify the following items:

- Make sure that all connectors are properly connected.
- Verify your boot devices.
- If the system does not start properly, try booting without any other I/O peripherals attached, including AMC adapters.

Make sure your system provides the minimum DC voltages required at the board's slot, especially if DC power is carried by cables.

If you are still not able to get your board running, contact our Technical Support for assistance.

Adapter Cables

Because adapter cables come from various manufacturers, pinouts can differ. The direct crimp design offered by Kontron allows the simplest cable assembly. All cables are available from Kontron Sales Department.

Storing Boards

Electronic boards are sensitive devices. Do not handle or store device near strong electrostatic, electromagnetic, magnetic or radioactive fields.

Regulatory Compliance Statements

FCC Compliance Statement for Class A Devices

This equipment has been tested and found to comply with the limits for a Class A digital device, pursuant to Part 15 of the FCC Rules. These limits are designed to provide reasonable protection against harmful interference in a residential installation. This equipment generated, uses and can radiate radio frequency energy and, if not installed and used in accordance with the instructions may cause harmful interference to radio communications. However, there is no guarantee that interference will not occur in a particular installation. If this equipment does cause harmful interference to radio or television reception, which can be determined by turning the equipment off and on, the user is encouraged to try to correct the interference by one or more of the following measures:

- Reorient or relocate the receiving antenna.
- Increase the separation between the equipment and receiver.
- Connect the equipment into an outlet on a circuit different from that to which the receiver is connected.
- Consult the dealer or an experience radio/TV technician for help.



WARNING

This is a Class A product. If not installed in a properly shielded enclosure and used in accordance with this User's Guide, this product may cause radio interference in which case users may need to take additional measures at their own expense.



Safety Certification

All Kontron equipment meets or exceeds safety requirements based on the IEC/EN/UL/CSA 60950-1 family of standards entitled, "Safety of information technology equipment." All components are chosen to reduce fire hazards and provide insulation and protection where necessary. Testing and reports when required are performed under the international IECCE CB Scheme. Please consult the "Kontron Safety Conformity Policy Guide" for more information. For Canada and USA input voltage must not exceed -60Vdc for safety compliance.

CE Certification

The product(s) described in this user's guide complies with all applicable European Union (CE) directives if it has a CE marking. For computer systems to remain CE compliant, only CE-compliant parts may be used. Maintaining CE compliance also requires proper cable and cabling techniques. Although Kontron offers accessories, the customer must ensure that these products are installed with proper shielding to maintain CE compliance. Kontron does not offer engineering services for designing cabling systems. In addition, Kontron will not retest or recertify systems or components that have been reconfigured by customers.

Limited Warranty

Kontron grants the original purchaser of Kontron's products a TWO YEAR LIMITED HARDWARE WARRANTY as described in the following. However, no other warranties that may be granted or implied by anyone on behalf of Kontron are valid unless the consumer has the express written consent of Kontron.

Kontron warrants their own products, excluding software, to be free from manufacturing and material defects for a period of 24 consecutive months from the date of purchase. This warranty is not transferable nor extendible to cover any other users or long-term storage of the product. It does not cover products which have been modified, altered or repaired by any other party than Kontron or their authorized agents. Furthermore, any product which has been, or is suspected of being damaged as a result of negligence, improper use, incorrect handling, servicing or maintenance, or which has been damaged as a result of excessive current/voltage or temperature, or which has had its serial number(s), any other markings or parts thereof altered, defaced or removed will also be excluded from this warranty.

If the customer's eligibility for warranty has not been voided, in the event of any claim, he may return the product at the earliest possible convenience to the original place of purchase, together with a copy of the original document of purchase, a full description of the application the product is used on and a description of the defect. Pack the product in such a way as to ensure safe transportation (see our safety instructions).

Kontron provides for repair or replacement of any part, assembly or sub-assembly at their own discretion, or to refund the original cost of purchase, if appropriate. In the event of repair, refunding or replacement of any part, the ownership of the removed or replaced parts reverts to Kontron, and the remaining part of the original guarantee, or any new guarantee to cover the repaired or replaced items, will be transferred to cover the new or repaired items. Any extensions to the original guarantee are considered gestures of goodwill, and will be defined in the "Repair Report" issued by Kontron with the repaired or replaced item.

Kontron will not accept liability for any further claims resulting directly or indirectly from any warranty claim, other than the above specified repair, replacement or refunding. In particular, all claims for damage to any system or process in which the product was employed, or any loss incurred as a result of the product not functioning at any given time, are excluded. The extent of Kontron liability to the customer shall not exceed the original purchase price of the item for which the claim exists.

Kontron issues no warranty or representation, either explicit or implicit, with respect to its products reliability, fitness, quality, marketability or ability to fulfil any particular application or purpose. As a result, the products are sold "as is," and the responsibility to ensure their suitability for any given task remains that of the purchaser. In no event will Kontron be liable for direct, indirect or consequential damages resulting from the use of our hardware or software products, or documentation, even if Kontron were advised of the possibility of such claims prior to the purchase of the product or during any period since the date of its purchase.

Please remember that no Kontron employee, dealer or agent is authorized to make any modification or addition to the above specified terms, either verbally or in any other form, written or electronically transmitted, without the company's consent.

Chapter 1

Product Description

- 1.1 Product Overview 2
- 1.2 What’s Included 2
- 1.3 Board Specifications 3
- 1.4 Compliance 5
- 1.5 Hot-Plug Capability..... 5
- 1.6 Interfacing with the Environment 5

1. Product Description

1.1 Product Overview

The Kontron AT8050 AdvancedTCA processor board redefines the design possibilities with a new Intel® microarchitecture processor, which offers greater efficiency and performance.

The AT8050 is a single-socket design with two featurerich processor options: an Intel Xeon Quad-Core L5518 (45nm) processor; or an Intel Xeon Six-Core L5638 (32nm) processor (BIOS 3.00 and highier). Both feature an Integrated Memory Controller, Turbo Boost Technology, Intel® QuickPath interconnect, and Intel® Hyper-Threading Technology (SMT). The Intel L5638 offers new hardware security features including the Intel® Advanced Encryption Standard - New Instructions (Intel® AES-NI) which enables fast and secure data encryption and decryption in AES-based communications cryptographic workloads, and offers a significant increase in performance compared to the current pure-software implementations.

The overall performance of the Kontron AT8050 will handle even the most demanding storage, medical imaging, security, and communications infrastructure applications.

With the available AdvancedMC bay, wireless/telecom equipment manufacturers can add multiple functionality with an assortment of Kontron AMC modules such the Kontron AM42xx series of Intelligent packet processor AMC modules, designed with the OCTEON Plus 5650 Network Service MIPS Processor from Cavium Networks.

1.2 What's Included

This board is shipped with the following items:

- One AT8050 board
- One RJ45-DB9 serial adaptor (1015-9404)
- One AMC filler panel
- Cables that have been ordered

If any item is missing or damaged, contact the supplier.

1.3 Board Specifications

Table 1-1: Board Specifications

Features	Description
Processors	<ul style="list-style-type: none"> Intel® Xeon® Quad-Core L5518 Processor (2.13 GHz, 8MB cache) (BIOS 3.00 and higher) or Intel® Xeon® Six-Core L5638 Processor (2 GHz, 12MB cache) Passive heatsink Virtualization Technology supported
Chipset	<ul style="list-style-type: none"> Intel 5520 I/O Hub (IOH 36D) & Intel I/O Controller Hub (ICH10R)
Bus Interface	<ul style="list-style-type: none"> CPU QuickPath Interconnect delivering up to 5.86 GT/s /lane PCIe
Expansion Slot	<ul style="list-style-type: none"> 1 Mid-size AdvancedMC bay x4 PCI Express 2x1000Base-BX Ports common option Dual port SAS(with RTM)/SATA 1 RS232 link to RTM
System Memory	<ul style="list-style-type: none"> Up to 48 GB on 6 latching sockets of VLP DDR-3 1066MHz RDIMM SDRAM ECC support, support S4EC/D4ED 3 DDR-3 channels, 2 DIMM per channel
Flash Memory	<ul style="list-style-type: none"> Two redundant 1MB BIOS (Field software upgradeable) Roll back functionality controlled by IPMC
Storage	<ul style="list-style-type: none"> 4 ports SAS/SATA available using RTM with the LSISAS1064e USB SSD Flash (many available sizes) daughter board iSCSI SATA AMC with ICH10 controller
I/O	<ul style="list-style-type: none"> Front Panel: Serial (RJ-45), 2 i82576 Management LAN (RJ-45), 2 USB PCIe Gen2 5Gb/s in Update Channel (AMC Carrier ATCA blade) Intel i82599 10Gb/s or 1Gb/s Ethernet Controller to Fabric Interface Intel i82576 1Gb/s to the Base Interface Management LAN can be used to provide 1000Base-BX interface to AMC P0 & P1, RTM SFPs or to the Fabric Interface P0s Synchronisation Clocks Interface support
Board Specifications	<ul style="list-style-type: none"> PICMG 3.0R3 / 3.1 option 9, option 2 PICMG AMC.0R2 / AMC.1 type 4 / AMC.2 type E2 & type 4 / AMC.3 PICMG HPM.1 IPMI 2.0
BIOS Features	<ul style="list-style-type: none"> AMI BIOS Warm reset support with memory protection for post-mortem analysis Save CMOS in SEEPROM option Boot from Ethernet PXE (Base and Fabric interfaces and management Lan) Boot from Ethernet iSCSI (Base and Fabric interfaces) Boot from SAS/SATA; and boot from USB 2.0 (Floppy, CD-ROM, Hard Disk) Diskless, Keyboard less, and battery less operation extensions System, video and LAN BIOS shadowing Robust BIOS flash Update with rollover capability (HPM.1) Field updateable BIOS Advanced Configuration and Power Interface (ACPI 1.0, 2.0 & 3.0) Console redirection to serial port (VT100)with CMOS setup access, and SOL (Serial over LAN) Event (correctable/uncorrectable ECC, POST errors); log support to IPMC

Features	Description
IPMI Features	<ul style="list-style-type: none"> • Management Controller compliant IPMI v2.0 and design to meet CP-TA v1.1 compliancy. • Remote control capability (power on-off /clean shutdown/warm reset/cold reset) via any IPMI channels including LAN. • Full speed 115200 bps Serial Over LAN (+LAN access to BIOS menu setup) and IPMI Over LAN (IPMI v2.0) always available. • Serial data caching and replay to ease software application troubleshooting and post mortem analysis. • BIOS Post Code error sent to chassis manager System Event Logging. • Configurable automatic “clean ACPI shutdown” policy on disk storage deactivation (AMC or RTM). • Standard PCIe Hot Plug operation embedded with PICMG AMC/RTM activation. • Robust IPMI firmware Update with rollover capability, without any payload impact (HPM.1). • Override configuration for activation of the board/AMC/RTM without Shelf Manager Intervention.
Supervisory	<ul style="list-style-type: none"> • Supports a system management interface (KCS interrupt driven) via an IPMI V2.0 compliant controller. • Standard IPMI Watchdog for all CPU running phase (BIOS execution / OS loading and running). • IPMI Hardware system monitor (power/voltages), memory and all critical components temperature is monitored. • Extensive sensors monitoring (around 100 IPMI sensors) and event generation base on thresholds and discrete reading.
OS Compatibility	<ul style="list-style-type: none"> • Validated with: Red Hat Enterprise Linux V.5.2, 7.1 & 7.2, WindRiver PNE Linux 2.0
Power Requirements	<p>120 W* -38V @ -72V with 12GB of memory, no RTM & no AMC. Maximum of 225W</p> <p>* The power consumption will vary depending on your product configuration (AMC, RTM & extra memory)</p>
Environmental Temperature*	<p>Operating: 0-55°C/32-131°F with 30CFM airflow</p> <p>Storage and Transit: -40 to +70°C/-40 to 158°F</p>
Environmental Humidity*	<p>Operating: 15% to 90% @55°C/131°F non-condensing</p> <p>Storage and Transit: 5% to 95% @ 40°C/104°F non-condensing</p>
Environmental Altitude*	<p>Operating: 4,000 m / 13,123 ft</p> <p>Storage and Transit: 15,000 m / 49,212 ft</p>
Environmental Shock*	<p>Operating: 3G each axis</p> <p>Storage and Transit: 18G each axis</p>
Environmental Vibration*	<p>Operating: 5-200Hz. 0.2G, each axis</p> <p>Storage and Transit: 5Hz to 20Hz @ 1 m2/s3 (0.01g2 /Hz) (flat)</p> <p>20Hz to 200Hz @ -3dB/oct (slope down)</p>
Reliability	<ul style="list-style-type: none"> • Whole board protected by active breaker • USB voltage protected by an active breakers
Safety / EMC	<p>Meet or exceed:</p> <ul style="list-style-type: none"> • Safety: UL 60950-1; CSA C22.2 No 60950-1-03; EN 60950-1:2001; IEC60950-1 • EMI/EMC: FCC 47 CFR Part 15, Class A; CE Mark to EN55022/EN55024/EN300386
Warranty	Two years limited warranty

* Designed to meet or exceed

1.4 Compliance

This product conforms to the following specifications:

- PICMG3.0 R3.0(Advanced TCA Base Specification)
- PICMG3.1 R1.0 (Ethernet/Fiber Channel over AdvancedTCA)
- AMC.0 R2.0 (Advanced Mezzanine Card Base Specification)
- AMC.1 R1.0 (Advanced Mezzanine Card PCI-Express)
- AMC.2 R1.0 (Advanced Mezzanine Card Ethernet)
- AMC.3 R1.0 (Advanced Mezzanine CardStorage)
- ACPI rev 2.0
- HPM.1
- IPMI 2.0

1.5 Hot-Plug Capability

The AT8050 supports Full Hot Swap capability as per PICMG3.0R3.0 for the board itself and AMC bay. It can be removed from or installed in the system while it is on (without powering-down the system). Please refer to the PICMG3.0R3.0 specification for additional details about Hot Swap.

The AT8050 supports PCI-Express Hotplug on AMC B1. The IPMC uses the standard PCI Express Hotplug Controller on the CPU board allowing hot insertion and removal of an AMC.1 module within the OS.

The AT8050 supports also the RTM Hotplug and the RTMDISK Hotplug.

1.6 Interfacing with the Environment

1.6.1 RTM (rear transition module)

The RTM8050 is a single slot (6HP) AdvancedTCA Rear Transition Module. This module provides additional connectivity for AT8050 CPU front blade.

1.6.1.1 Standard Compliance

- PICMG3.0 R3.0 - Advanced Telecommunication Computing Architecture
- SFF-8470 (T10 Technical Committee and SCSI Trade Association)

1.6.1.2 *Serial Port Feature*

- One serial ports available on the RTM face plate through a RJ-45 connector.
- RS-232 signal levels at RTM face plate connector.
- Serial port speed capability is: 9.6kbits/s to 115.2kbits/s.

1.6.1.3 *Hot Swap*

The RTM8050 supports hot swapping by using the switch connected to the face plate lower ejector. This switch indicates the coming hot swap action. The insertion of the RTM to a slot is always done over a non powered connector. During the extraction procedure, the management power is disabled only when the RTM8050 is removed. This procedure meets the AdvancedTCA AMC behavior.

1.6.1.3.1 *Inserting the RTM8050 into the slot*

The presence of the RTM is indicated by one signal. The front blade IPMC recognizes the RTM insertion when the signal is low. After recognizing the RTM, the IPMC turns the blue LED ON and enables the management power to the RTM. Once the IPMB-L link is working, the IPMC accesses the MMC to retrieve FRU data. After knowing the type of RTM inserted, the IPMC negotiates with the shelf manager in order to activate the +12V payload power. After RTM local voltages have been ramped up, the RTM's MMC enables the RTM Link.

After this the front board IPMC informs the shelf manager there is a functional RTM blade present.

1.6.1.3.2 *Removing the RTM8050 from the slot*

The RTM_EJECT signal goes HIGH by opening the RTM lower ejector handle. This indicates to the front blade IPMC that a hot swap action is going to take place. The IPMC then negotiates the removal with the System manager and if it is granted, it proceeds with the removal process.

The IPMC proceeds to the deactivation by disabling ekey governed links, the IPMC then disables the RTM Link and turns OFF the payload +12V power. When it is safe to remove the RTM blade from the slot, the IPMC turns the Blue / Hot Swap LED ON. Front Blade IPMC turns OFF the management power only when there is no RTM detected. (RTM8050 removed from the slot)

1.6.2 Advanced Mezzanine Card

The AT8050 has one AMC bay. Using a mezzanine allows to add storage or I/O not provided on board.

1.6.2.1 *AMC Expansion*

The AMC slot provides an AMC.1 type 4, AMC.2 Type E2 and 4, AMC.3 Dual Port SAS. This means that the following signaling are supported:

- PCI-Express X4 on AMC ports 4-7
- PCI-Express clock on FCLKA
- Gigabit Ethernet on AMC port 0 and 1
- Telco clocks on TCLKA, B, C, D
- SAS on AMC port 2 and 3
- OEM RS232 connection on port 15
- Gigabit Ethernet on AMC port 8, 9, 10 and 11.

Chapter 2

Board Features

2.1	Block Diagram	9
2.2	System Core	10
2.3	USB 2.0 Interfaces.....	11
2.4	USB Flash Module.....	12
2.5	Serial ATA/Serial Attached SCSI.....	12
2.6	Update Channel	13
2.7	Real Time Clock & NVRAM	13
2.8	Redundant BIOS Flash	13
2.9	Ethernet Interfaces.....	14
2.10	Serial Interfaces.....	24
2.11	AMC Mezzanine	24
2.12	FPGA.....	26
2.13	Telecom Clock Option	26
2.14	Redundant IPMC Firmware & BootBlock.....	26
2.15	LEDs Description	27

2. Board Features

2.1 Block Diagram

Figure 2-1: Block Diagram

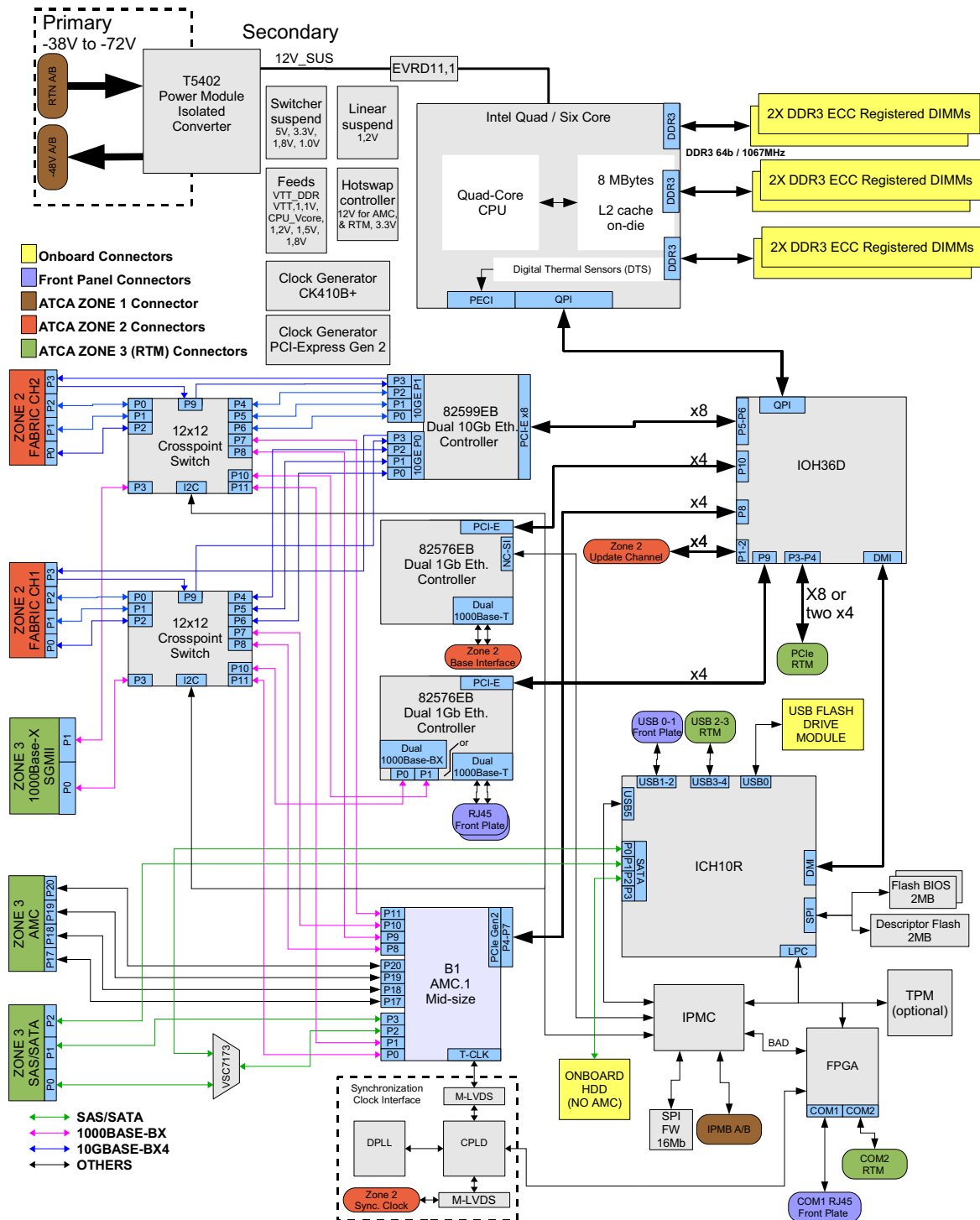

2.2 System Core

2.2.1 Processor

- Built on 45/32 nanometer process technology.
- Quad/Six core processor in 1366-land FCLGA.
- On-die, 8 MB/12MB L3 shared cache
- Streaming SIMD Extension 2, 3 and 4 (SSE2, SSE3 and SSE4)
- Integrated 3-channel DDR3 controller, DDR3-1066 memory with ECC
- Intel QuickPath interconnect links, 5.86 GT/s in each direction
- Intel 64 Architecture
- Enhanced Intel SpeedStep Technology
- Intel Virtualization Technology
- Simultaneous Multi-Threading

2.2.2 Intel IOH 36D

- QuickPath interconnect to the CPU
- 36 PCI Express 2.0 lanes (5.0Gb/sec/lane/direction)
- Direct Media Interface (DMI,ESI) x4 lanes for communicating with the Intel ICH10

2.2.3 ICH10R

- Direct Media Interface (DMI, ESI) x4 lanes for communicating with the Intel IOH
- Real Time Clock
- Serial ATA controller
- Advanced Host Controller Interface
- Intel Matrix Storage Technology
- Low Pin Count (LPC) Interface
- Serial Peripheral Interface

- DMA Controller, Timer/Counters, Interrupt Controller
- Universal Serial Bus (USB)
- GPIOs
- Enhanced Power Management
- System Management Bus 2.0 (SMBus)

2.3 USB 2.0 Interfaces

The board embeds a USB controller. This controller is compliant to USB 2.0. It provides two USB ports on the face plate and two on the RTM. Those ports can be used for external storage and for booting.

USB features include:

- Capability to daisy chain as many as 127 devices per interface
- Fast bi-directional
- Isochronous/asynchronous interface
- 480 Mbs transfer rate
- Standardization of peripheral interfaces into a single format
- Retro compatible with USB 1.1 devices

USB supports Plug and Play and hot-swapping operations (OS level). These features allow USB devices to be automatically attached, configured and detached, without reboot or running setup.

Table 2-1:USB Connector Pinout

Pin	Signal
1	VCC
2	DATA-
3	DATA+
4	GND



Signal Path:

- 2 USB 2.0 on front panel (J10)
- 2 USB 2.0 on the RTM front panel



BIOS Settings:

Advanced --> USB Configuration

2.4 USB Flash Module

The AT8050 supports Solid State Drive. It is a NAND flash disk module with a USB 2.0 interface. The module is socketed on a 2x5 header attached to the AT8050 PCB. Here are the main features:

- Many available sizes
- Mean-Time Between Failures (MTBF) of 5 millions hours
- 5 Years Useful Life under specific conditions
- Read throughput of 28MB/second
- Write throughput of 20MB/second
- I/O Operations per second of 100 (4KB random 2 Read + 1 Write)
- 5V operating voltage
- 0 to 70 Celsius operating temperature



Signal Path:

USB Flash Module Connector is available on J22



BIOS Settings:

Advanced --> USB Configuration
Boot --> USB drives (to deactivate)



Note:

During the installation of an OS on a HDD, the USB Flash Module must be deactivated. If the USB Flash Module remains active, the Master Boot Record will be installed on it by default. This can not be avoided and will cause the OS to be unable to boot when booting from the HDD.

2.5 Serial ATA/Serial Attached SCSI

2.5.1 Serial Attached SCSI (LSISAS1064e is PCI-e rev 1.1)

This option is only available through a combination of the RTM8050 and AT8050, on which the controller resides. Two SAS ports are routed from the RTM8050 to the AMC Bay (more details in the AMC Mezzanine section below).

The RTM8050 features a SAS controller (the LSISAS1064e is PCI-e rev 1.1) which interfaces with the AT8050 by a dedicated PCI Express connection or through the Update Channel Interface such as the Kontron carrier AMC AT8402. If the RTM controller is used, a SAS or SATA hard drive can be located in the AT8050 AMC bay or in the RTM8050 Hard Disk tray, but thermal restrictions on the type of supported hard drives applies (standard 15mm SAS drives with 60 Celsius maximum Tcase are not supported over specified operating

temperature). The SAS controller can be on a AMC carrier blade connected to the AT8050 through x4 PCIeExpress in the Update Channel Interface. See the AMC carrier blade's specification for more information about its storage capabilities and restrictions.

2.5.2 Serial ATA (ICH10R)

SATA ports are locally available from the AT8050.

One ICH10R SATA port is connected to the AMC Port 2 through a multiplexer.

The ICH10R SATA host controller supports independent DMA operation and supports data transfer rates of up to 3.0 Gb/s (300 MB/s). The SATA controller contains two modes of operation - a legacy mode using I/O space, and an AHCI mode using memory space. When configured in legacy mode, the SATA controller doesn't provide AHCI capabilities. The ICH10R supports the Serial ATA Specification, Revision 1.0a. The ICH10 also supports several optional sections of the Serial ATA II: Extensions to Serial ATA 1.0 Specification, Revision 1.0 (AHCI support is required for some elements).

2.6 Update Channel

The AT8050 update channel can be used to interface with an AMC carrier blade, such as the AT8402 Kontron AMC carrier, via x4 PCI-Express link. This feature offer additional application possibilities to the AT8050. Consult the AMC carrier blade's technical reference manual for more information about these possibilities or contact your local technical support team for further details about the update channel.

2.7 Real Time Clock & NVRAM

The AT8050 is a battery less board. The real time clock and non-volatile RAM integrated in the ICH are powered by the suspend power when available. A SuperCap provides sufficient power to retain the real time clock for a typical duration of 2hrs. The real time clock precision is 100ppm or better.

Although it is possible to save the CMOS setup in NVRAM (or CMOS RAM), the default configuration saves the setup in flash. So, when the AT8050 is unpowered for too long, only the time and date will be lost.

2.8 Redundant BIOS Flash

Two BIOS SPI flash are present on the AT8050. If for some reason a BIOS update corrupts a flash and it prevents the CPU from completing the boot sequence, the IPMC will swap the active SPI flash and force a reboot.



Note:

Since the CMOS setup is saved in flash, this will also restore the previous BIOS setup.



BIOS Settings:

Management --> System Information --> BIOS In Use
Exit --> Exit and Execute BIOS Swap

2.9 Ethernet Interfaces

2.9.1 Fabric Interface

The fabric interface can be either 10GbE or 1GbE. An E-Keying configuration is required to properly route the desired connection speed.

The AT8050 has boot from LAN capability (PXE) or iSCSI support on these ports. Enable the option from the BIOS Setup Program. Please refer to Section 5.1, AMI BIOS Set-up Program.

2.9.1.1 10GbE (i82599EB) connectivity:

The AT8050 has one dual port 10GbE controller (i82599EB) connected to the Fabric Interface. This controller can also be used as a dual 1Gb.

2.9.1.2 1GbE (i82576EB) connectivity:

While normally connected to the front panel, the i82576EB (1GbE) controller can be connected to the Fabric interface instead of the i82599EB(10GbE). 10GbE connectivity will no longer be available.

2.9.1.3 i82599EB (Fabric Interface)

Features high performance with TCP/IP and UDP/IP checksum offloading for IPv4 and IPv6, packet filtering, and jumbo frame up to 15.5K.

See <http://www.intel.com> for additional details on the i82599EB.

2.9.1.4 i82576EB (Base Interface and Management Interface)

Features high performance with TCP/IP and UDP/IP checksum offloading for IPv4 and IPv6, packet filtering, and jumbo frame up to 16K.

See <http://www.intel.com> for additional details on the i82576EB.



Signal Path:

The two ports are available on the Fabric Interface.



BIOS Settings:

Advanced --> Expansion ROM Configuration



BIOS Settings:

System Management --> Oem E-keying configuration --> Management LAN Setting

2.9.2 Base Interface

An i82576EB dual port 1Gb Ethernet controller is features on the Base Interface.

Boot from LAN capability (PXE) or iSCSI is supported on these ports. Enable the option from the BIOS Setup Program. Please refer to Section 5.1, AMI BIOS Set-up Program.



Signal Path:

The two ports are available on the Base Interface.



BIOS Settings:

Advanced --> Expansion ROM Configuration

2.9.3 Management Interface

The management interface is featured by the second i82576EB dual port 1Gb Ethernet controller. By means of cross-point switch, it can achieve the following connectivity:

- front panel with two 10/100/1000Base-T RJ45 interfaces
- AMC (port 0-1)
- RTM
- The Fabric Interface (disables 10GbE connectivity)



Signal Path:

The front panel, or on the AMC, or on the RTM.



BIOS Settings:

Advanced --> Expansion ROM Configuration
System Management --> OEM E-Keying Configuration

2.9.4 Ethernet Interfaces Configuration

Many Ethernet configurations are available with the crosspoint switch. Below is a block diagram that shows all the supported crosspoint switch configurations.

Figure 2-2: Available Ethernet Interfaces Configurations

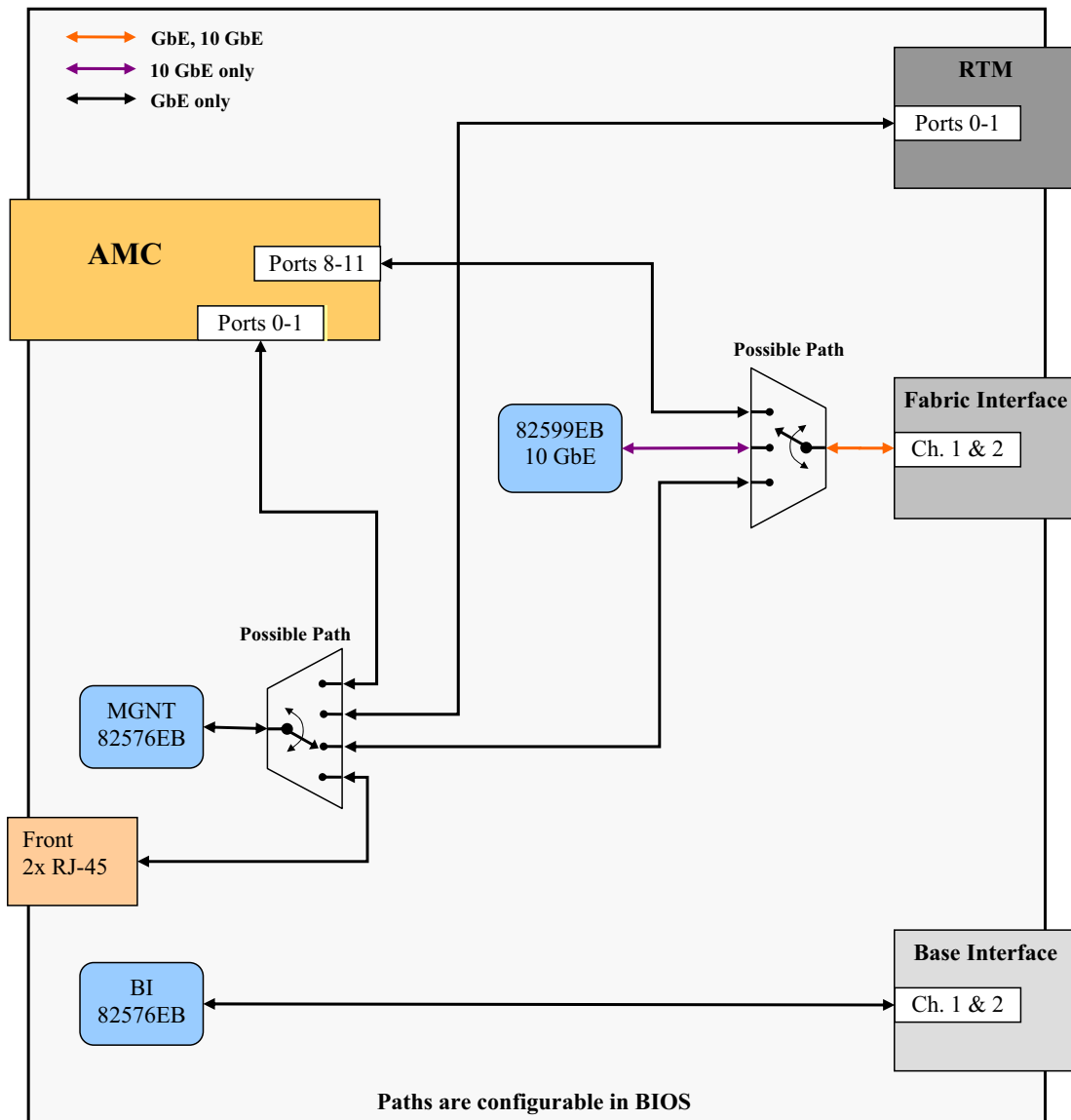

Note:

- The AMC must be able to support GbE on ports 8-11
- Connection from AMC to the Fabric Interface is either PICMG3.1 option 2 (2x1GbE) or PICMG3.1 option 1 (1xGbE).

2.9.4.1 10GbE and Management to Front Panel Configuration

Figure 2-3: 10GbE and Management to Front Panel

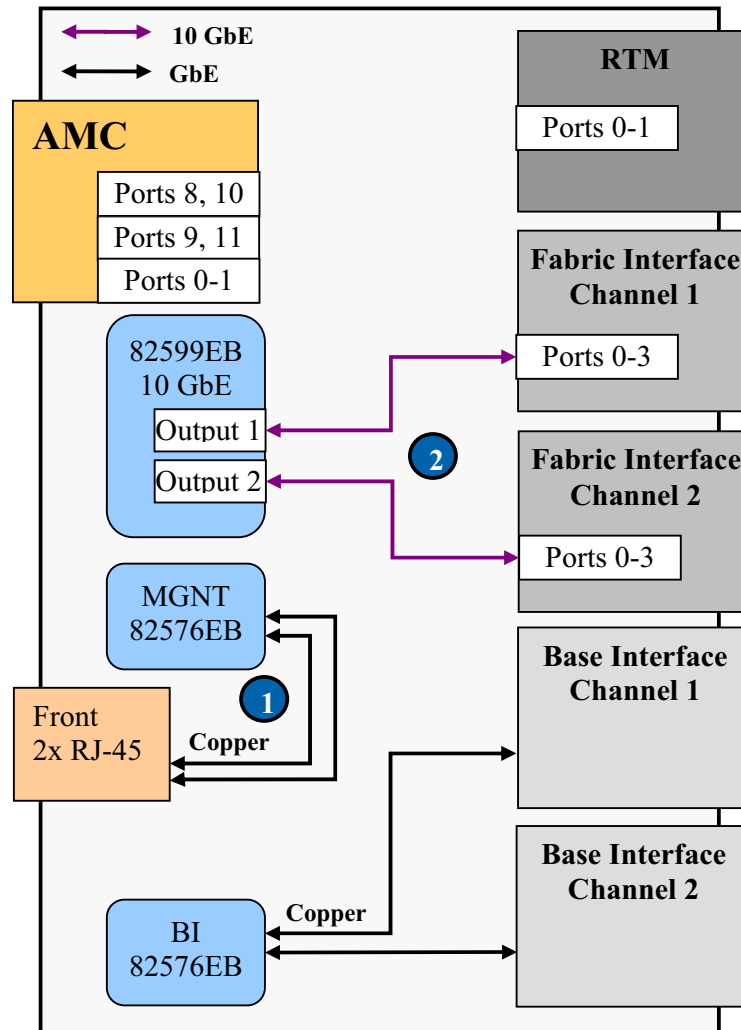

BIOS Settings:

- 1) System Management --> OEM E-Keying Configuration --> Management LAN Setting: Front Panel
- 2) System Management --> OEM E-Keying Configuration --> AMC P8-11 Setting: Disabled

2.9.4.2 10GbE and Management to AMC Configuration

Figure 2-4: 10GbE and Management to AMC

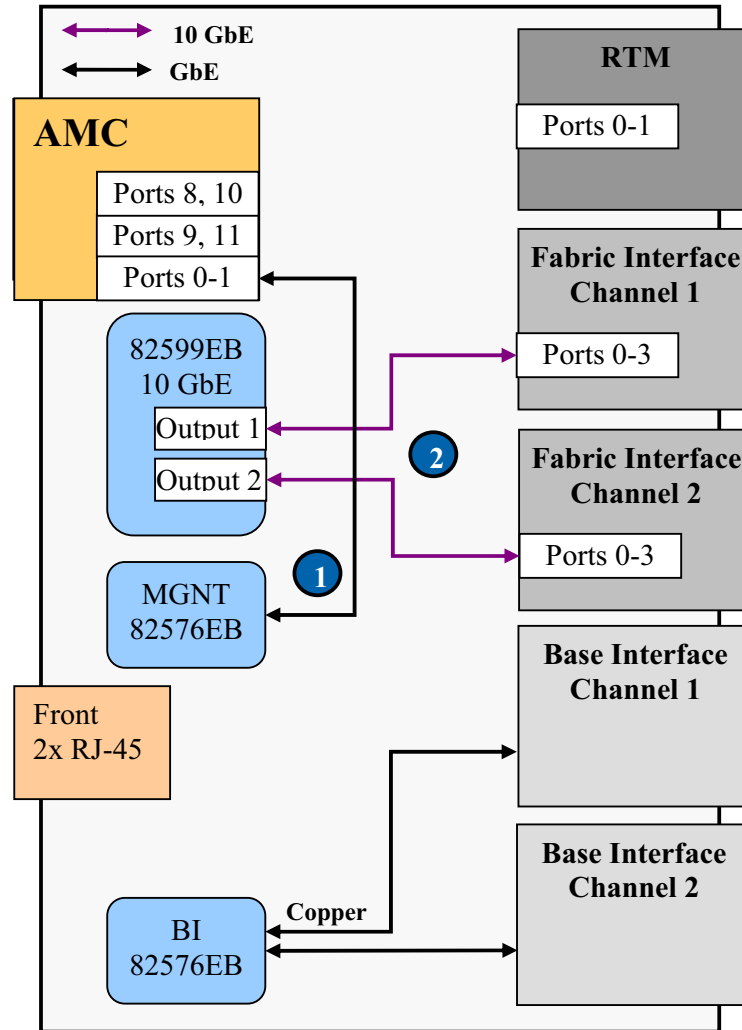

BIOS Settings:

- 1) System Management --> OEM E-Keying Configuration --> Management LAN Setting: AMC.2 Module
- 2) System Management --> OEM E-Keying Configuration --> AMC P8-11 Setting: Disabled

2.9.4.3 10GbE and Management to RTM Configuration

Figure 2-5: 10GbE and Management to RTM

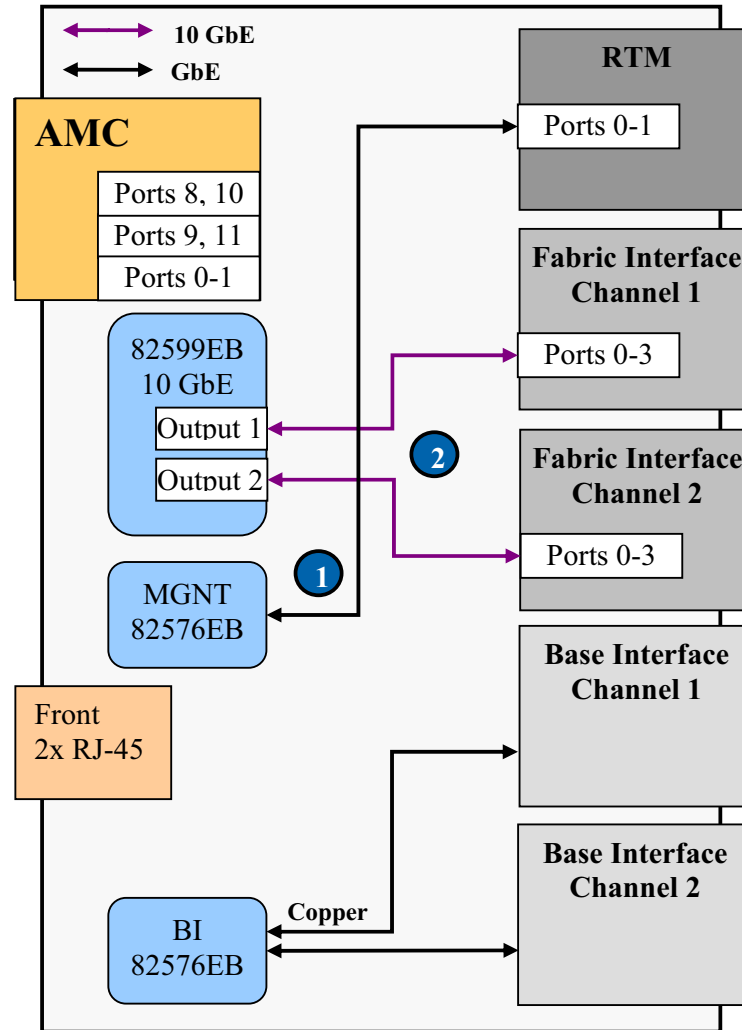

BIOS Settings:

- 1) System Management --> OEM E-Keying Configuration --> Management LAN Setting: RTM
- 2) System Management --> OEM E-Keying Configuration --> AMC P8-11 Setting: Disabled

2.9.4.4 AMC to Fabric Interface and Management to Front Panel Configuration

Figure 2-6: AMC to Fabric Interface and Management to Front Panel

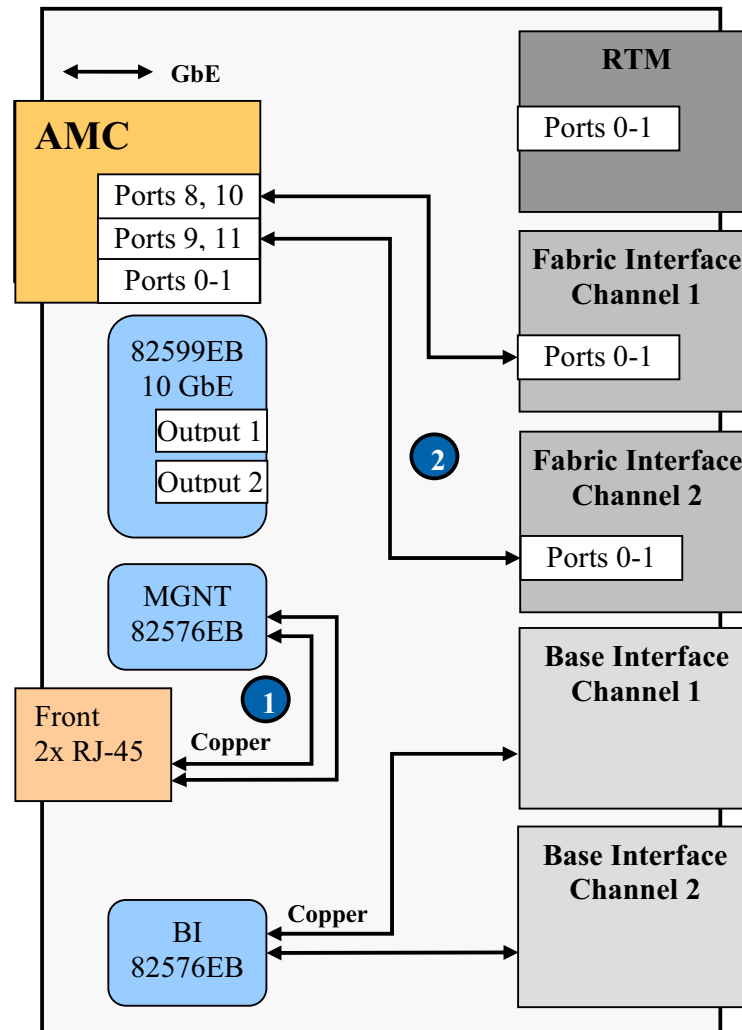

Note:

- The AMC must be able to support GbE on ports 8-11
- Connection from AMC to the Fabric Interface is either PICMG3.1 option 2 (2x1GbE) or PICMG3.1 option 1 (1xGbE).



BIOS Settings:

- 1) System Management --> OEM E-Keying Configuration --> Management LAN Setting: Front Panel
- 2) System Management --> OEM E-Keying Configuration --> AMC P8-11 Setting: Fabric Interface
In this configuration, it is not possible to boot from the Fabric Interface

2.9.4.5 AMC to Fabric Interface and Management to AMC Configuration

Figure 2-7: AMC to Fabric Interface and Management to AMC

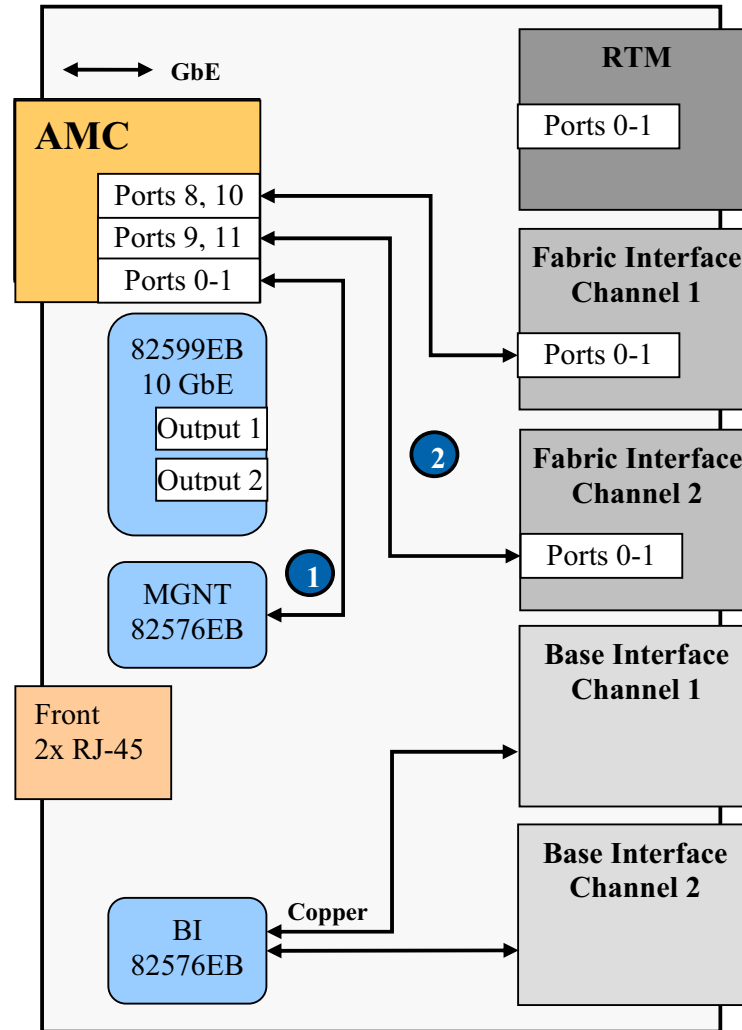

Note:

- The AMC must be able to support GbE on ports 8-11
- Connection from AMC to the Fabric Interface is either PICMG3.1 option 2 (2x1GbE) or PICMG3.1 option 1 (1xGbE).



BIOS Settings:

- 1) System Management --> OEM E-Keying Configuration --> Management LAN Setting: AMC.2 Module
- 2) System Management --> OEM E-Keying Configuration --> AMC P8-11 Setting: Fabric Interface
In this configuration, it is not possible to boot from the Fabric Interface

2.9.4.6 AMC to Fabric Interface and Management to RTM Configuration

Figure 2-8: AMC to Fabric Interface and Management to RTM

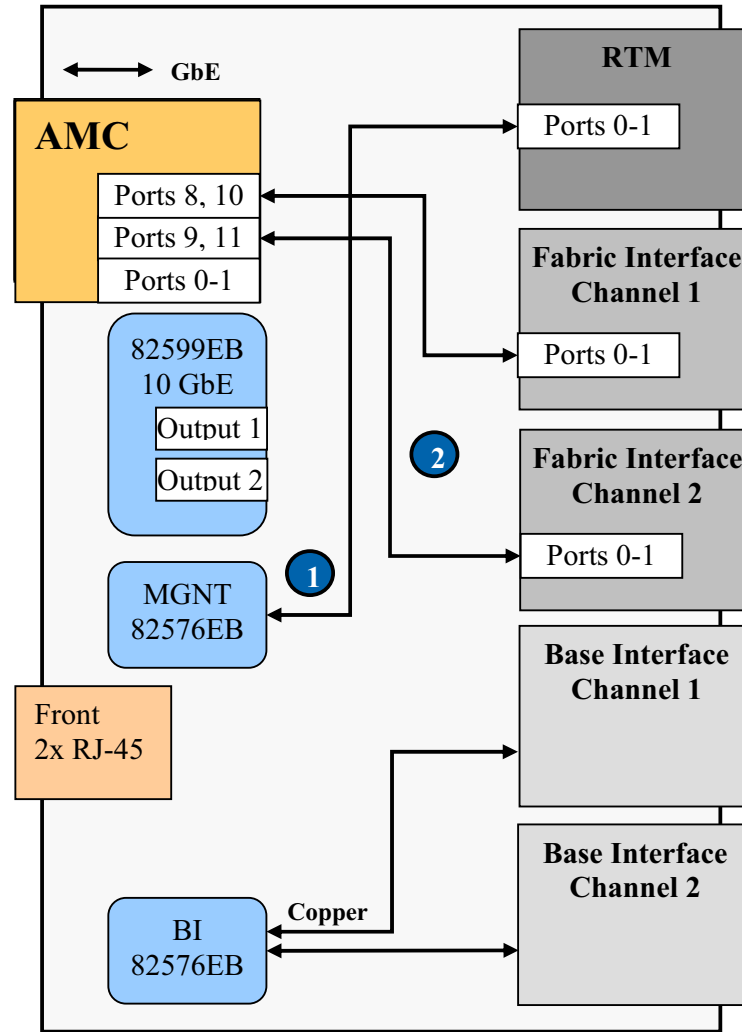

Note:

- The AMC must be able to support GbE on ports 8-11
- Connection from AMC to the Fabric Interface is either PICMG3.1 option 2 (2x1GbE) or PICMG3.1 option 1 (1xGbE).



BIOS Settings:

- 1) System Management --> OEM E-Keying Configuration --> Management LAN Setting: RTM
 - 2) System Management --> OEM E-Keying Configuration --> AMC P8-11 Setting: Fabric Interface
- In this configuration, it is not possible to boot from the Fabric Interface

2.9.4.7 Management to Fabric Interface Configuration

Figure 2-9: Management to Fabric Interface

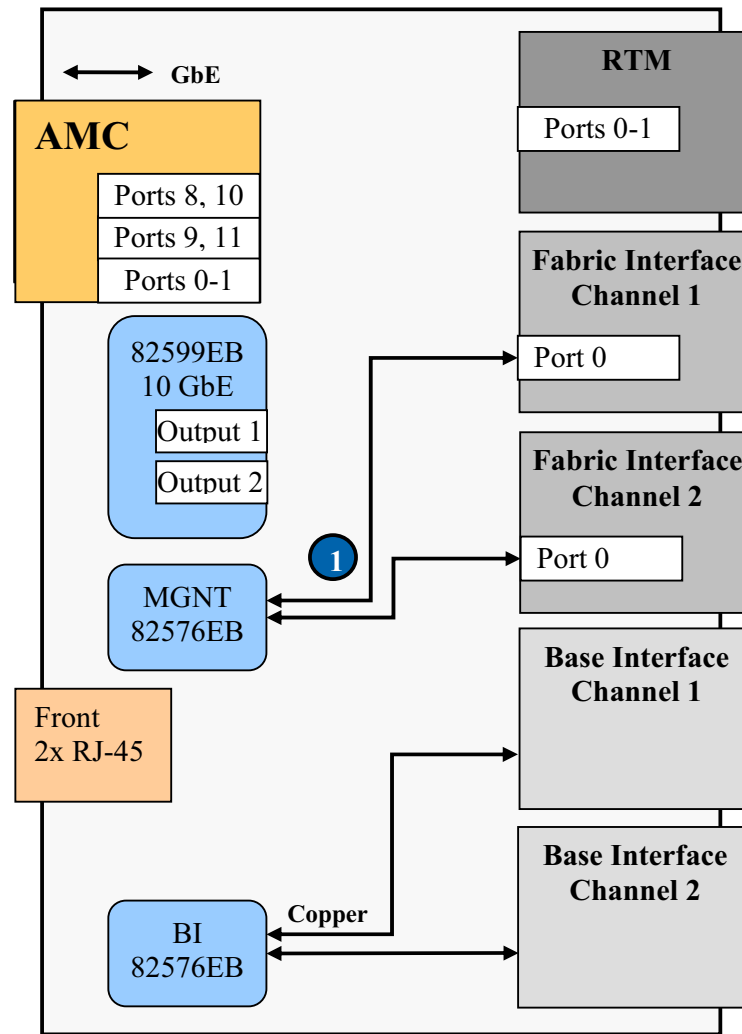

BIOS Settings:

- 1) System Management --> OEM E-Keying Configuration --> Management LAN Setting: Fabric Interface
System Management --> OEM E-Keying Configuration --> AMC P8-11 Setting: Disabled

2.10 Serial Interfaces

The AT8050 uses serial interfaces to manage the CPU. Since no video interface is provided on board, the only way to get visual information on the board is the serial console. Serial ports are provided on the faceplate and on the RTM faceplate for asynchronous serial communications. They are 16C550 high-speed UART compatible and support 16-byte FIFO buffers for transfer rates from 9,6Kbps to 115,2Kbps.

Table 2-2:Serial Interface connector Pinout

Pin	Signal
1	RTS
2	DTR
3	TX#
4	GND
5	GND
6	RX#
7	DSR
8	CTS



Note:

Standard product uses a RJ-45 8 pins connector. RI (ring indicator) and DCD (data carrier detect) signals are not available.
The pinout is a custom one, not the same as RS-232D TIA/EIA-561.



Signal Path:

COM1 is routed to a RJ45 on the frontplate or to the IPMC for SOL.
COM2 is routed to the RTM or the AMC serial interface port is routed directly to the RTM.



BIOS Settings:

System Management --> Remote Access Configuration
System Management --> OEM E-Keying Configuration

2.11 AMC Mezzanine

The AMC slot supports AMC.1 (PCIe), AMC.2 (Gigabit Ethernet) and AMC.3 (SAS/SATA) in addition to the AMC.0 base specification. The AMC is hot swappable according to PICMG 3.0 Rev. 2.0 and supports mid-size AMC units.

One AMC site is available. Characteristics of the AMC are as follow:

- Type B+
- Support mid-size single width mechanical format
- PCI-Express X4 (GEN2 2.5GTs or 5.0GTs) with reference clock on AMC FCLKA

- Fully compliant PCI-Express hot plug support
- Provision for telecom clocks on TCLKA, B, C, D
- SAS link from RTM connector
- Compliant to AMC.0, AMC.1, AMC.2 and AMC.3
- Serial Port (AMC port 15)
- 50W maximum power budget

As per AMC.1 R2.0, the carrier board is required to provide PCIe 100MHz reference clock to the AMC on FCLKA. However, modules are not required to use it. Kontron recommends using AMC-Express modules that use the reference clock on FCLKA. If the module makes its own reference clock, then the spread spectrum of PCI-Express clock synthesizer will be disabled by e-keying; otherwise the behavior of the PCI-Express link will be erratic.



Note:

All electromagnetic compatibility testing has been done with spread spectrum. Disabling the spread spectrum can complicate EMC.

The SAS interface on port 2 allows to use a SAS AMC storage mezzanine on the AT8050 and also accommodates SATA drives. AMC SATA/SAS electrical path are properly design for Hot Swap operation but special care must be taken to ensure proper un-mount sequence within the operating system.

AMC port 3 is supplied by the RTM for SAS connectivity.

The telco clock signals allow the AT8050 to provide clocks to the AMC on TCLKA and TCLKC. It also allows an AMC to retrieve a clock and to provide it to the system through TCLKB and TCLKD. For possible clock frequency and connection with the backplane, refer to section Telecom Clock Option.



BIOS Settings:

Advanced --> Drives Configuration
 Advanced --> Expansion ROM Configuration
 Advanced --> PCI Express Configuration
 System Management --> OEM E-Keying Configuration



Software Usage:

To access the SAS BIOS press "CTRL-C" when the board boots.
 You can also access the SAS controller by using the LSI Util (Linux Tool)



Software Usage:

AMC serial port is available on port 15.
 AMC serial port GUID : 471C5D14-2AE7-42B9-A9B0-0628546B42CC



Signal Path:

To use the SAS interface, an RTM8050 must be installed.



Note:

The maximum power budget is 50W for an Advanced Mezzanane Card.

2.12 FPGA

The FPGA has many functions. One of them is to act as a companion chip to the IPMC. The states of all the critical signals controlled by the IPMC are memorized in the FPGA and are preserved while the IPMC firmware is being updated.

The FPGA is a RAM-based chip that is preloaded from a separate flash memory at power-up. Two such flash memory devices are provided; one that can only be programmed in factory and the other one that can be updated in the field. The factory flash is selected by inserting jumper JP1 pins 3-4. Field updates require to cycle the power of the board. The IPMI LED2 will blink if the factory flash is being used.

The FPGA update complies to PICMG HPM.1 specification and is remotely updatable via any IPMC channel.

2.13 Telecom Clock Option

The telecom clock option is not shown on the main block diagram. The circuit is made of MLVDS buffers, a PLD and a multi-service line card PLL. The PLD is hooked to the main FPGA with a fast serial link and from there, to the IPMC via a proprietary bus.

The PLD receives 19.44MHz clocks from the backplane (CLK2A and CLK2B) and use it as a reference to the DPLL. Anyone of the PLL clock outputs can be used to feed the AMC's TCLKA using the FPGA interface. If a backplane clock is lost, the circuit will automatically switch to the redundant clock. If all backplane clocks are lost, the PLL will switch to holdover mode until a clock reappears. If both copies of the 19.44MHz from CLK2A and CLK2B are lost, the clock control circuitry activates an alarm to the IPMC as long as the telecom sync option is enabled in the shelf.

The PLD is field upgradeable. If upgrade is necessary for this device, an appropriate procedure will be provided with the code update.

Refer to the register description in appendix and to the ZL30108 datasheet available on Zarlink's web site (www.zarlink.com) for further details on possible clock speed and configuration.

2.14 Redundant IPMC Firmware & BootBlock

The IPMC runs a firmware from its internal 512KB flash. The IPMC Boot Block saves the last two copies of the IPMC firmware image in dedicated SPI flash memory. The Boot Block manages the IPMC reprogramming and can rollback to the previous firmware image in the IPMC internal flash in case of update problem.



Note:

The IPMC has an external hardware watchdog

2.15 LEDs Description

The following table lists the LED on the faceplate (not counting the RJ-45 Ethernet LED).

Table 2-3:Faceplate LEDs

LED Name	Color	Controlled by	Description
ATCA0	Blue	IPMC	Blade Hot Swap status
ATCA1	Amber/Red	IPMC	Blade OOS (out-of-service)
ATCA2	Amber/Green	IPMC	Healthy status
ATCA3	Amber/Green	IPMC/CPU	Application specific
Strip1-L0	Amber/Green	FPGA	Base Interface Channel 1 Status
Strip1-L1	Amber/Green	FPGA	Base Interface Channel 2 Status
Strip1-L2	Amber/Green	FPGA	Fabric Interface Channel 1 Status
Strip1-L3	Amber/Green	FPGA	Fabric Interface Channel 2 Status
Strip2-L0	Amber/Green	FPGA	SAS/SATA local disks activity
Strip2-L1	Amber/Green	FPGA	SAS external disk activity
Strip2-L2	Amber/Green	FPGA	Alternate LAN configuration
Strip2-L3	Amber/Green	FPGA	Alternate LAN configuration

2.15.1 Hot Swap LED (LED0)

The Blue / Hot Swap LED indicates the hot swap status of the RTM. The LED is ON when it is safe to remove the RTM from the slot. During normal operation, this LED is OFF.

2.15.2 Out Of Service (LED1)

The AdvancedTCA LED1 is red or amber and indicates an Out-of-Service (OOS) condition. During normal operation, the OOS LED is OFF. This LED is ON during firmware upgrade and is user configurable if needed by a customer application.

2.15.3 Healthy LED (LED2)

The AdvancedTCA LED2 is green or amber and indicates a healthy condition. The healthy LED indicates if the blade is powered up and all voltages and temperatures are within specifications. During normal operation, this LED is ON (green). This LED is also ON (amber) when one of the RTM8050 voltage or temperature fails.

Figure 2-10: Faceplate LEDs

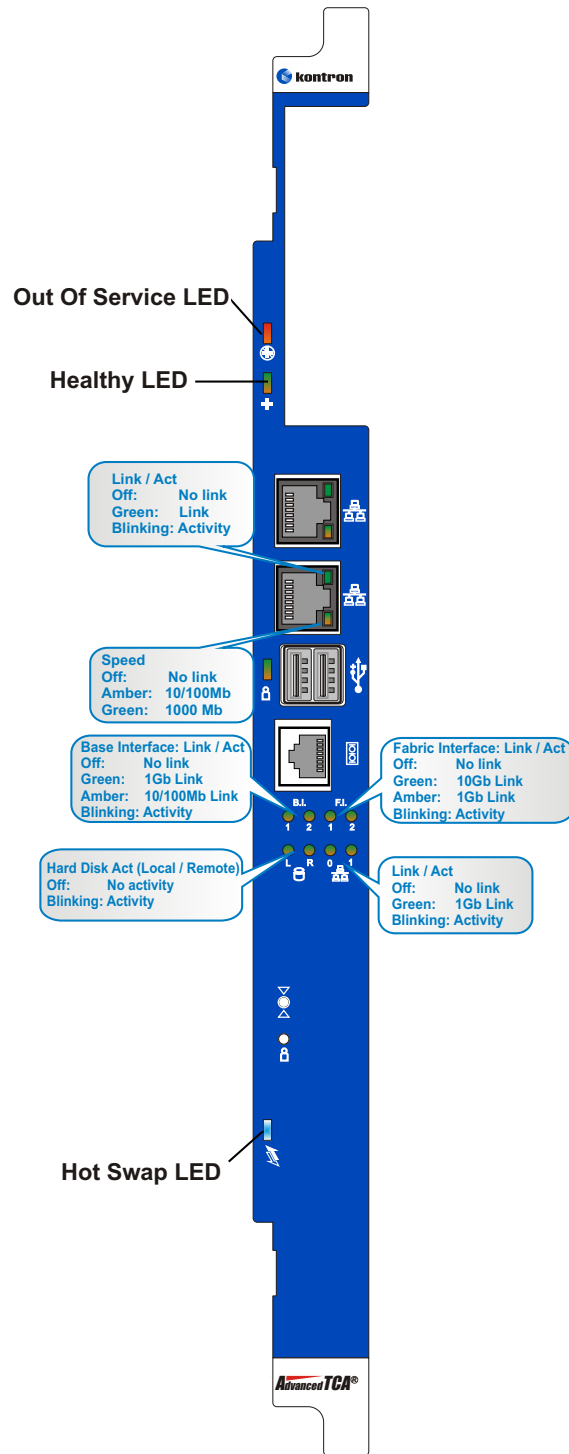

Note:

Disk activity is obtained directly from the ICH for SATA and from RTM-Link for SAS links of the SAS controller located on the RTM. If the SAS controller is accessed through the Update Channel it doesn't provide any activity status.

Chapter 3

Installing the Board

3.1	Setting Jumpers.....	30
3.2	Processor.....	31
3.3	Memory.....	31
3.4	Onboard Connectors and Headers	34
3.5	Board Hot Swap and Installation	35

3. Installing the Board

3.1 Setting Jumpers

3.1.1 Jumper Description

Table 3-1: Jumper Description

Name	Description	Jumper
FW Write Protect	When On, it enables the firmware write protect	JP1 (1-2)
FPGA PROM Selection	When On, it selects the factory prom	JP1 (3-4)
Clear CMOS Setup	When On, it clears the CMOS Setup	JP1 (5-6)
Reserved	Reserved	JP1 (7-8)
Reserved	Reserved	JP1 (9-10)
Reserved	Reserved	JP1 (11-12)
Reserved	Reserved	JP1 (13-14)
Watchdogs	When On, it disables the watchdogs	JP2 (1-2)
Shelf Manager Activation	When On, it overrides the Shelf Manager activation	JP2 (3-4)
IPMI	When On, it resets the IPMC	JP2 (5-6)
AMC & RTM Activation	When On, it overrides the AMC & RTM activation	JP2 (7-8)
Reserved	Reserved	JP2 (9-10)
Reserved	Reserved	JP2 (11-12)
Reserved	Reserved	JP2 (13-14)

3.1.2 Setting Jumper & Locations

Figure 3-1: Jumper Settings and Locations

JUMPER SETTINGS (• Default Setting)

JP1 (1-2) FW Write Protect	
Protected	in
• Non Protected	out
JP1 (3-4) FPGA PROM Selection	
Factory Prom	in
• Normal	out
JP1 (5-6) Clear CMOS Setup	
Clear CMOS	in
• Normal Operation	out
JP1 (7-8) Reserved	
Reserved	in
• Reserved	out
JP1 (9-10) Reserved	
Reserved	in
• Reserved	out
JP1 (11-12) Reserved	
Reserved	in
• Reserved	out
JP1 (13-14) Reserved	
Reserved	in
• Reserved	out
JP2 (1-2) Watchdogs	
Disabled	in
• Enabled	out
JP2 (3-4) Shelf Manager Activation	
Override	in
• Normal Operation	out
JP2 (5-6) IPMI	
Override	in
• Normal	out
JP2 (7-8) AMC & RTM Activation	
Override	in
• Normal Operation	out
JP2 (9-10) Reserved	
Reserved	in
• Reserved	out
JP2 (11-12) Reserved	
Reserved	in
• Reserved	out
JP2 (13-14) Reserved	
Reserved	in
• Reserved	out



Note:

More details about the jumper settings can be found on the Quick Reference Sheet.

3.2 Processor

This product ships with the CPUs and a thermal solution installed. The thermal solution is custom and critical for passive cooling. Cooling performance can greatly be affected if manipulation is not handled within Kontron facility. Do not attempt any heat sink removal.

3.3 Memory

The AT8050 has 3 memory channels connected to the main CPU. There are 2 DIMMs per memory channels for a total of 6. The AT8050 accepts DDR3, VLP(very low-profile) (0.72 inch; 18.29mm), 1.5V typical, registered, ECC, x4 or x8 memory with up to 4 ranks per DIMM. The DDR3 memory channels run at 1066MHz with the 60W Nehalem. A minimum memory size of 2 Gbyte is supported using a single DIMM. The maximum DDR3 SDRAM size is 8GBytes per DIMM for a populated 48GBytes maximum. Memory modules shall have a validated thermal solution (heatsink) and may necessitate a certain class of chassis. It is recommended that modules have thermal sensors for accurate temperature monitoring and to throttle the memory interface in case of overheating. Memory can perform double refresh rate to get higher maximum operating temperature.

The content of the SDRAM is not affected by a warm reset.

Always populate DIMM0(J14, J16 & J18) first, then DIMM1(J13, J15 & J17) on each channel.

Only use validated memory with this product. Thermal issues or other problems may arise if you don't use recommended modules. At the time of publication of this user guide, the following memories have been qualified and approved. As the memory market is volatile, this list is subject to change, please consult your local technical support for an up to date list.

3.3.1 Memory List and Characteristics

Table 3-2: Approved Memory List

Manufacturer Part Number	Description	Company
VL33B5663F-F8M	DIMM DDR3-1066 2GB256M*72 REG ECC 0.70"	VIRTUUM
SG572568FH8P6LC2	DIMM DDR3-1066 2GB256M*72 REG ECC 0.70"	Smart modular
VL33B5168F-F8M	DIMM_DDR3-1066_4GB_512M*72_REG_ECC_0.70"	VIRTUUM
VL33B5168F-F8S	DIMM_DDR3-1066_4GB_512M*72_REG_ECC_0.70"	VIRTUUM
VL33B5663F-F8S-H	DIMM DDR3-1066 2GB256M*72 REG ECC 0.733"	VIRTUUM
VL33B5663E-F8M	DIMM DDR3-1066 2GB256M*72 REG ECC 0.733"	VIRTUUM

Memory should have the following characteristics:

- DDR3 1066
- 1.5V typical
- Single or dual-rank modules are supported
- x4 or x8 memory with up to 4 ranks per DIMM
- Registered & ECC
- Only very low profiles (VLP) 0.72inches maximum heights (18.3mm)



WARNING



Because static electricity can cause damage to electronic devices, take the following precautions:

Keep the board in its anti-static package, until you are ready to install memory.

Wear a grounding wrist strap before removing the board from its package; this will discharge any static electricity that may have built up in your body.

Handle the board by the faceplate or its edges.

3.3.2 Installing Memory

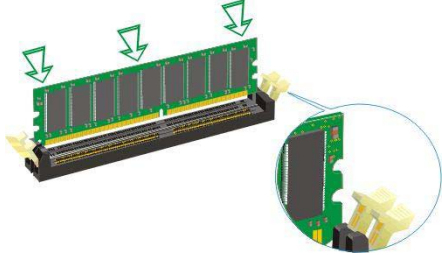
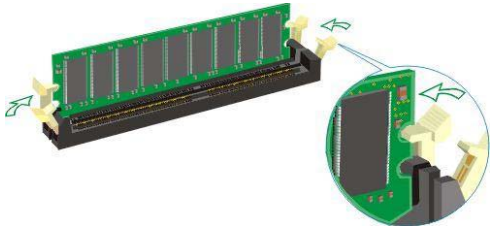
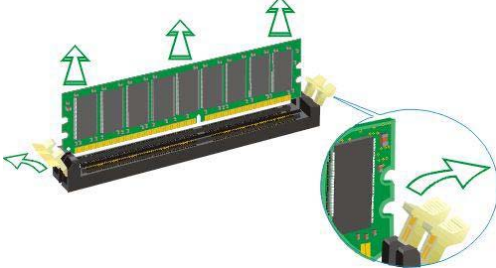
<p>On an anti-static plane, place the board so that you are facing the front plate connectors</p>	
<p>Remove the memory protection top cover.</p>	
<p>Insert the memory module into any available socket, aligning the notches on the module with the socket's key inserts.</p>	
<p>1- Insert the memory module in the connector using your thumbs. 2- Eject partially the memory module, using the connector latches while applying some pressure on the top to avoid the full removal of the modules. 3- Fully Reseat the modules in the connector using your thumbs. 4- Repeat steps 2 and 3 a second time. 5- Push down the memory module until the retaining clips lock on each side.</p>	
<p>Repeat these steps to populate the other socket.</p>	
<p>To remove a memory module from a socket, push sideways the retaining clips on each side of the socket, to release the module. Pull out the memory from the socket.</p>	

3.4 Onboard Connectors and Headers

Table 3-3: Onboard Connectors and Headers

Description	Connector	Comments
Post Codes	J2	Post Code Connector
AMC	J5	AMC Connector
Ethernet Port 1	J8	RJ-45 Ethernet Connector
Ethernet Port 0	J9	RJ-45 Ethernet Connector
USB (2x Stacked)	J10	Two stacked USB connectors
Serial Port (COM1)	J12	RJ-45 Serial Port connector
DDR3 Memory Sockets	J13-J18	Memory Sockets
Synchronisation Clcoks, Update Channel	J20	
USB Flash Drive	J22	9 pins header for the USB Flash Drive Mezzanine
Base Interface & Fabric Interface	J23	
RTM	J30	
Power & IPMB	P10	

Figure 3-2: Onboard Connectors and Headers Locations

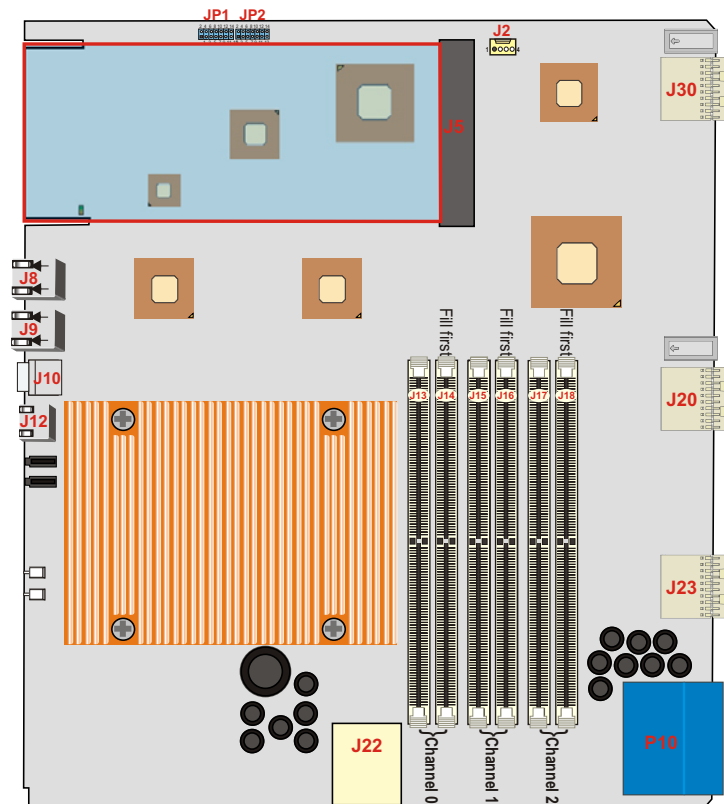

3.5 Board Hot Swap and Installation

Because of the high-density pinout of the hard-metric connector, some precautions must be taken when connecting or disconnecting a board to/from a backplane:

- 1 Rail guides must be installed on the enclosure to slide the board to the backplane.
- 2 Do not force the board if there is mechanical resistance while inserting the board.
- 3 Screw the frontplate to the enclosure to firmly attach the board to its enclosure.
- 4 Use ejector handles to disconnect and extract the board from its enclosure.



WARNING

Always use a grounding wrist wrap before installing or removing the board from a chassis.



3.5.1 Installing the Board in the Chassis

To install a board in a chassis:

- 1 Remove the filler panel of the slot or see "Removing the Board" below.
- 2 Ensure the board is configured properly.
- 3 Carefully align the PCB edges in the bottom and top card guide.
- 4 Insert the board in the system until it makes contact with the backplane connectors.
- 5 Using both ejector handles, engage the board in the backplane connectors until both ejectors are locked.
- 6 Fasten screws at the top and bottom of the faceplate.

3.5.2 Removing the Board

If you would like to remove a card from your chassis please follow carefully these steps:

- 1 Unscrew the top and the bottom screw of the front panel.
- 2 Unlock the lower handle latch, depending on the software step; this may initiate a clean shutdown of the operating system.
- 3 Wait until the blue LED is fully ON, this mean that the hot swap sequence is ready for board removal.
- 4 Use both ejectors to disengage the board from the backplane.
- 5 Pull the board out of the chassis.

3.5.3 Installing an AMC

To install an AMC:

- 1 Remove the AMC filler panel.
- 2 Carefully engage the AMC into the card guide. Push the AMC until it fully mate with its connector. Secure the AMC handle to the locking position.
- 3 In normal condition, the blue LED shall turn ON as soon as the AMC is fully inserted. It will turn OFF at the end of the hot swap sequence.

3.5.4 Removing an AMC

To remove an AMC:

- 1 Pull out the handle to unlock the AMC.
- 2 Wait for the blue LED to turn on continuously.
- 3 Pull out the AMC using the handle.

3.5.5 Installing the RTM8050

To install the RTM:

- 1 Remove the filler panel of the slot.
- 2 Ensure the board is configured properly.
- 3 Carefully align the PCB edges in the bottom and top card guide.
- 4 Insert the board in the system until it makes contact with the CPU board.
- 5 Using both ejector handles, engage the board in the CPU board connectors until both ejectors are locked.
- 6 Fasten screws at the top and bottom of the faceplate.

3.5.6 Removing the RTM8050

To remove the RTM:

- 1 Unscrew the top and the bottom screw of the faceplate.
- 2 Unlock the lower handle latch.
- 3 Wait until the blue LED is fully ON, this mean that the hot swap sequence is ready for board removal.
- 4 Use both ejectors to disengage the board from the CPU board.
- 5 Pull the board out of the chassis.

Chapter 4

Hardware Management

4.1	Hardware Management Overview	38
4.2	Hardware Management Functionality	38
4.3	IPMC	40

4. Hardware Management

4.1 Hardware Management Overview

The purpose of the hardware management system is to monitor, control, insure proper operation and provide hot swap support of ATCA Boards. The hardware management system watches over the basic health of the system, reports anomalies, and takes corrective action when needed. The hardware management system can retrieve inventory information and sensor readings as well as receive event reports and failure notifications from boards and other Intelligent FRUs. The hardware management system can also perform basic recovery operations such as power cycle or reset of managed entities.

4.2 Hardware Management Functionality

The Front Blade Unit supports an “intelligent” hardware management system, based on the Intelligent Platform Management Interface Specification. The hardware management system of the Front Blade Unit provides the ability to manage the power and interconnect needs of intelligent devices, to monitor events, and to log events to a central repository.

4.2.1 IPMC specific features

4.2.1.1 *IPMC - ShMC interface*

The principal management-oriented link within a Shelf is a two-way redundant implementation of the Intelligent Platform Management Bus (IPMB). IPMB is based on the inter-integrated circuit (I2C) bus and is part of the IPMI architecture. In AdvancedTCA Shelves, the main IPMB is called IPMB-0. Each entity attached to IPMB-0 does so through an IPM Controller, the distributed management controller of the IPMI architecture. Shelf Managers attach to IPMB-0 through a variant IPM Controller called the Shelf Management Controller (ShMC). AdvancedTCA IPM Controllers, besides supporting dual redundant IPMBs, also have responsibility for detecting and recovering from IPMB faults.

The reliability of the AdvancedTCA IPMB-0 is increased by using two IPMBs, with the two IPMBs referenced as IPMB-A and IPMB-B. The aggregation of the two IPMBs is IPMB-0. The IPM Controllers aggregate the information received on both IPMBs. An IPM Controller that has a message ready for transmit uses the IPMBs in a round robin fashion. An IPM Controller tries to alternate the transmission of messages between IPMB-A and IPMB-B.

If an IPM Controller is unable to transmit on the desired IPMB then it tries to send the message on the alternate IPMB. By using this approach, an IPMB can become unavailable and then available without the IPM Controller needing to take specific action.

4.2.1.2 *IPMC - System Manager Interface*

The Section 24 of [IPMI 2.0] describes how IPMI messages can be sent to and from the IPMC encapsulated in RMCP (Remote Management Control Protocol) packets datagrams. This capability is also referred to as “IPMI over LAN” (IOL). IPMI also defines the associated LAN-specific configuration interfaces for setting things such as IP addresses other options, as well as commands for discovering IPMI-based systems. The Distributed Management Task Force (DMTF) specifies the RMCP format. This LAN communication path make the Front Blade Unit reachable to the System Manager for any management action (IPMC firmware upgrade, query of all FRU Data, CPU reset etc.) without the need to go through the ShMC.

4.2.1.3 *IPMC - System Event Log*

The Kontron IPMC implementation includes a Local System Event Log device as specified in the Section 31 of [IPMI 2.0]. The local System Event Log is a nonvolatile repository for the front board and all managed FRU events (AMC/RTM). The local SEL provides space for up to 1023 (0x03ff) entries. However, even if blade events are logged into the local SEL, the IPMI platform event messages are still generated by the IPMC's Event Generator and sent to the centralized SEL hosted by the Shelf Manager through the IPMB-0 communication path - [PICMG 3.0] chapter 3.5; [IPMI 2.0] Section 29. Local SEL is useful for maintenance purposes and provides access to the events when the FRU is extracted from the Shelf.

4.2.2 **Sensors**

For more details about onboard sensors consult the application note: AN09003. This application note is available from the Kontron web site at: www.kontron.com

4.3 IPMC

4.3.1 Supported commands

The table below lists the IPMI commands supported by the IPMC. This table is identical as the one provided by AMC.0 and PICMG 3.0. The last column states the Kontron support for the specific command.

Table 4-1:IPM Device Supported Commands for IPMC

	IPMI Spec. section	NetFn	CMD	IPMI BMC req.	Carrier IPMC req.	Kontron support on IPMC
IPM Device "Global" Commands				M	M	
Get Device ID	20.1	App	01h	M	M	Yes
Cold Reset	20.2	App	02h	0	0	Yes
Warm Reset	20.3	App	03h	0	0	No
Get Self Test Results	20.4	App	04h	M	M	Yes
Manufacturing Test On	20.5	App	05h	0	0	Yes
Set ACPI Power State	20.6	App	06h	0	0	Yes
Get ACPI Power State	20.7	App	07h	0	0	Yes
Get Device GUID	20.8	App	08h	0	0	Yes
Broadcast "Get Device ID"	20.9	App	01h	0/M	M	Yes

Table 4-2:Watchdog Timer Supported Commands for IPMC

	IPMI Spec. section	NetFn	CMD	IPMI BMC req.	Carrier IPMC req.	Kontron support on IPMC
BMC Watchdog Timer Commands				M	M	
Reset Watchdog Timer	27.5	App	22h	M	M	Yes
Set Watchdog Timer	27.6	App	24h	M	M	Yes
Get Watchdog Timer	27.7	App	25h	M	M	Yes

Table 4-3:Device Messaging Supported Commands for IPMC

	IPMI Spec. section	NetFn	CMD	IPMI BMC req.	Carrier IPMC req.	Kontron support on IPMC
BMC Device and Messaging Commands[5]				M	0	
Set BMC Global Enables	22.1	App	2Eh	M	0/M	Yes
Get BMC Global Enables	22.2	App	2Fh	M	0/M	Yes
Clear Message Flags	22.3	App	30h	M	0/M	Yes

	IPMI Spec. section	NetFn	CMD	IPMI BMC req.	Carrier IPMC req.	Kontron support on IPMC
Get Message Flags	224	App	31h	M	0/M	Yes
Enable Message Channel Receive	22.5	App	32h	0	0	Yes
Get Message	22.6	App	33h	M	0/M	Yes
Send Message	22.7	App	34h	M	M	Yes
Read Event Message Buffer	22.8	App	35h	0	0	Yes
Get BT Interface Capabilities	22.10	App	36h	M	0/M	No
Get System GUID	22.14	App	37h	0	0	Yes
Get Channel Authentication Capabilities	22.13	App	38h	0	0	Yes
Get Session Challenge	22.15	App	39h	0	0	Yes
Activate Session	22.17	App	3Ah	0	0	Yes
Set Session Privilege Level	22.18	App	3Bh	0	0	Yes
Close Session	22.19	App	3Ch	0	0	Yes
Get Session Info	22.20	App	3Dh	0	0	Yes
Get AuthCode	22.21	App	3Fh	0	0	No
Set Channel Access	22.22	App	40h	0	0	Yes
Get Channel Access	22.23	App	41h	0	0	Yes
Get Channel Info	22.24	App	42h	0	0	Yes
Set User Access	22.26	App	43h	0	0	Yes
Get User Access	22.27	App	44h	0	0	Yes
Set User Name	22.28	App	45h	0	0	Yes
Get User Name	22.29	App	46h	0	0	Yes
Set User Password	22.30	App	47h	0	0	Yes
Activate Payload	24.1	App	48h			Yes
Deactivate Payload	24.2	App	49h			Yes
Get Payload Activation Status	24.4	App	4Ah			Yes
Get Payload Instance Info	24.5	App	4Bh			Yes
Set User Payload Access	24.6	App	4Ch			Yes
Get User Payload Access	24.7	App	4Dh			Yes
Get Channel Payload Support	24.8	App	4Eh			Yes
Get Channel Payload Version	24.9	App	4Fh			Yes
Get Channel OEM Payload Info	24.10	App	50h			No
Master Write-Read	22.11	App	52h			Yes

	IPMI Spec. section	NetFn	CMD	IPMI BMC req.	Carrier IPMC req.	Kontron support on IPMC
Get Channel Cipher Suites	22.15	App	54h			Yes
Suspend/Resume Payload Encryption	24.3	App	55h			Yes
Set Channel Security Keys	22.25	App	56h			Yes
Get System Interface Capabilities	22.9	App	57h			Yes

Table 4-4:Chassis Device Supported Commands for IPMC

	IPMI Spec. section	NetFn	CMD	IPMI BMC req.	Carrier IPMC req.	Kontron support on IPMC
Chassis Device Commands				0	0	
Get Chassis Capabilities	28.1	Chassis	00h	M	0	Yes
Get Chassis Status	28.2	Chassis	01h	0/M	0	Yes
Chassis Control	28.3	Chassis	02h	0/M	0	Yes
Chassis Reset	28.4	Chassis	03h	0	0	No
Chassis Identify	28.5	Chassis	04h	0	0	No
Set Chassis Capabilities	28.7	Chassis	05h	0	0	No
Set Power Restore Policy	28.8	Chassis	06h	0	0	No
Get System Restart Cause	28.11	Chassis	07h	0	0	No
Set System Boot Options	28.12	Chassis	08h			Yes
Get System Boot Options	28.13	Chassis	09h			Yes
Get POH Counter	22.12	Chassis	0Fh	0	0	No

Table 4-5:Event Supported Commands for IPMC

	IPMI Spec. section	NetFn	CMD	IPMI BMC req.	Carrier IPMC req.	Kontron support on IPMC
Event Commands				M	M	
Set Event Receiver	29.1	S/E	01h	M	M	Yes
Get Event Receiver	29.2	S/E	02h	M	M	Yes
Platform Event	29.3	S/E	03h	M	M	Yes

Table 4-6:PEF and Alerting Supported Commands for IPMC

	IPMI Spec. section	NetFn	CMD	IPMI BMC req.	Carrier IPMC req.	Kontron support on IPMC
PEF and Alerting Commands				0	0	
Get PEF Capabilities	30.1	S/E	10h	M	M	No
Arm PEF Postpone Timer	30.2	S/E	11h	M	M	No
Set PEF Configuration Parameters	30.3	S/E	12h	M	M	No
Get PEF Configuration Parameters	30.4	S/E	13h	M	M	No
Set Last Processed Event ID	30.5	S/E	14h	M	M	No
Get Last Processed Event ID	30.6	S/E	15h	M	M	No
Alert Immediate	30.7	S/E	16h	0	0	No
PET Acknowledge	30.8	S/E	17h	0	0	No

Table 4-7:Sensor Device Supported Commands for IPMC

	IPMI Spec. section	NetFn	CMD	IPMI BMC req.	Carrier IPMC req.	Kontron support on IPMC
Sensor Device Commands				0	M	
Get Device SDR Info	35.2	S/E	20h	0	M	Yes
Get Device SDR	35.3	S/E	21h	0	M	Yes
Reserve Device SDR Repository	35.4	S/E	22h	0	M	Yes
Get Sensor Reading Factors	35.5	S/E	23h	0	M	No
Set Sensor Hysteresis	35.6	S/E	24h	0	0	Yes
Get Sensor Hysteresis	35.7	S/E	25h	0	0	Yes
Set Sensor Threshold	35.8	S/E	26h	0	0	Yes
Get Sensor Threshold	35.9	S/E	27h	0	0	Yes
Set Sensor Event Enable	35.10	S/E	28h	0	0	Yes
Get Sensor Event Enable	35.11	S/E	29h	0	0	Yes
Re-arm Sensor Events	35.12	S/E	2Ah	0	0	No
Get Sensor Event Status	35.13	S/E	2Bh	0	0	No
Get Sensor Reading	35.14	S/E	2Dh	M	M	Yes
Set Sensor Type	35.15	S/E	2Eh	0	0	No
Get Sensor Type	35.16	S/E	2Fh	0	0	No

Table 4-8:FRU Device Supported Commands for IPMC

	IPMI Spec. section	NetFn	CMD	IPMI BMC req.	Carrier IPMC req.	Kontron support on IPMC
FRU Device Commands				M	M	
Get FRU Inventory Area Info	34.1	Storage	10h	M	M	Yes
Read FRU Data	34.2	Storage	11h	M	M	Yes
Write FRU Data	34.3	Storage	12h	M	M	Yes

Table 4-9:SDR Device Supported Commands for IPMC

	IPMI Spec. section	NetFn	CMD	IPMI BMC req.	Carrier IPMC req.	Kontron support on IPMC
SDR Device Commands				M	O	
Get SDR Repository Info	33.9	Storage	20h	M	M	No
Get SDR Repository Allocation Info	33.10	Storage	21h	O	O	No
Reserve SDR Repository	33.11	Storage	22h	M	M	No
Get SDR	33.12	Storage	23h	M	M	No
Add SDR	33.13	Storage	24h	M	O/M	No
Partial Add SDR	33.14	Storage	25h	M	O/M	No
Delete SDR	33.15	Storage	26h	O	O	No
Clear SDR Repository	33.16	Storage	27h	M	O/M	No
Get SDR Repository Time	33.17	Storage	28h	O/M	O/M	No
Set SDR Repository Time	33.18	Storage	29h	O/M	O/M	No
Enter SDR Repository Update Mode	33.19	Storage	2Ah	O	O	No
Exit SDR Repository Update Mode	33.20	Storage	2Bh	M	M	No
Run Initialization Agent	33.21	Storage	2Ch	O	O	No

Table 4-10:SEL Device Supported Commands for IPMC

	IPMI Spec. section	NetFn	CMD	IPMI BMC req.	Carrier IPMC req.	Kontron support on IPMC
SEL Device Commands				M	O	
Get SEL Info	31.2	Storage	40h	M	M	Yes
Get SEL Allocation Info	31.3	Storage	41h	O	O	Yes
Reserve SEL	31.4	Storage	42h	O	O	Yes
Get SEL Entry	31.5	Storage	43h	M	M	Yes
Add SEL Entry	31.6	Storage	44h	M	M	Yes
Partial Add SEL Entry	31.7	Storage	45h	M	M	No
Delete SEL Entry	31.8	Storage	46h	O	O	Yes

	IPMI Spec. section	NetFn	CMD	IPMI BMC req.	Carrier IPMC req.	Kontron support on IPMC
Clear SEL	31.9	Storage	47h	M	M	Yes
Get SEL Time	31.10	Storage	48h	M	M	Yes
Set SEL Time	31.11	Storage	49h	M	M	Yes
Get Auxiliary Log Status	31.12	Storage	5Ah	0	0	No
Set Auxiliary Log Status	31.13	Storage	5Bh	0	0	No

Table 4-11:LAN Device Supported Commands for IPMC

	IPMI Spec. section	NetFn	CMD	IPMI BMC req.	Carrier IPMC req.	Kontron support on IPMC
LAN Device Commands				0	0	
Set LAN Configuration Parameters	23.1	Transport	01h	0/M	0/M	Yes
Get LAN Configuration Parameters	23.2	Transport	02h	0/M	0/M	Yes
Suspend BMC ARPs	23.3	Transport	03h	0/M	0/M	Yes
Get IP/UDP/RMCP Statistics	23.4	Transport	04h	0	0	Yes

Table 4-12:Serial/Modem Device Supported Commands for IPMC

	IPMI Spec. section	NetFn	CMD	IPMI BMC req.	Carrier IPMC req.	Kontron support on IPMC
Serial/Modem Device Commands				0	0	
Set Serial/Modem Configuration	25.1	Transport	10h	0/M	0/M	No
Get Serial/Modem Configuration	25.2	Transport	11h	0/M	0/M	No
Set Serial/Modem Mux	25.3	Transport	12h	0	0	No
Get TAP Response Codes	25.4	Transport	13h	0	0	No
Set PPP UDP Proxy Transmit Data	25.5	Transport	14h	0	0	No
Get PPP UDP Proxy Transmit Data	25.6	Transport	15h	0	0	No
Send PPP UDP Proxy Packet	25.7	Transport	16h	0	0	No
Get PPP UDP Proxy Receive Data	25.8	Transport	17h	0	0	No

	IPMI Spec. section	NetFn	CMD	IPMI BMC req.	Carrier IPMC req.	Kontron support on IPMC
Serial/Modem Connection Active	25.9	Transport	18h	0/M	0/M	No
Callback	25.10	Transport	19h	0	0	No
Set User Callback Options	25.11	Transport	1Ah	0	0	No
Get User Callback Options	25.12	Transport	1Bh	0	0	No

Table 4-13: SOL Commands

	IPMI Spec. section	NetFn	CMD	IPMI BMC req.	Carrier IPMC req.	Kontron support on IPMC
SOL Commands				0	0	
SOL Activating	26.1	Transport		20h		No
Set SOL Configuration Params	26.2	Transport		21h		Yes
Get SOL Configuration Params	26.3	Transport		22h		Yes

Table 4-14: PICMG 3.0 Commands for IPMC

	IPMI Spec. section	NetFn	CMD	IPMI BMC req.	Carrier IPMC req.	Kontron support on IPMC
AdvancedTCA®	PICMG® 3.0 Table				M	
Get PICMG Properties	3-11	PICMG	00h		M	Yes
Get Address Info	3-10	PICMG	01h		M	Yes
Get Shelf Address Info	3-16	PICMG	02h		0	Yes
Set Shelf Address Info	3-17	PICMG	03h		0	No
FRU Control	3-27	PICMG	04h		M	Yes
Get FRU LED Properties	3-29	PICMG	05h		M	Yes
Get LED Color Capabilities	3-30	PICMG	06h		M	Yes
Set FRU LED State	3-31	PICMG	07h		M	Yes
Get FRU LED State	3-32	PICMG	08h		M	Yes
Set IPMB State	3-70	PICMG	09h		M	Yes
Set FRU Activation Policy	3-20	PICMG	0Ah		M	Yes
Get FRU Activation Policy	3-21	PICMG	0Bh		M	Yes
Set FRU Activation	3-19	PICMG	0Ch		M	Yes
Get Device Locator Record ID	3-39	PICMG	0Dh		M	Yes
Set Port State	3-59	PICMG	0Eh		0/M	Yes
Get Port State	3-60	PICMG	0Fh		0/M	Yes

	IPMI Spec. section	NetFn	CMD	IPMI BMC req.	Carrier IPMC req.	Kontron support on IPMC
Compute Power Properties	3-82	PICMG	10h		M	Yes
Set Power Level	3-84	PICMG	11h		M	Yes
Get Power Level	3-83	PICMG	12h		M	Yes
Renegotiate Power	3-91	PICMG	13h		O	No
Get Fan Speed Properties	3-86	PICMG	14h		M if controls Shelf fans	No
Set Fan Level	3-88	PICMG	15h		O/M	No
Get Fan Level	3-87	PICMG	16h		O/M	No
Bused Resource	3-62	PICMG	17h		O/M	Yes
Get IPMB Link Info	3-68	PICMG	18h		O/M	Yes
Get Shelf Manager IPMB Address	3-38	PICMG	1Bh		M	No
Set Fan Policy	3-89	PICMG	1Ch		M	No
Get Fan Policy	3-90	PICMG	1Dh		M	No
FRU Control Capabilities	3-29	PICMG	1Eh		M	Yes
FRU Inventory Device Lock Control	3-42	PICMG	1Fh		M	No
FRU Inventory Device Write	3-43	PICMG	20h		M	No
Get Shelf Manager IP Addresses	3-36	PICMG	21h		M	No
Get Shelf Power Allocation	3-85	PICMG	22h		M	No
Get Telco Alarm Capability	3-93	PICMG	29h		O/M	No
Set Telco Alarm State	3-94	PICMG	2Ah		O/M	No
Get Telco Alarm State	3-95	PICMG	2Bh		O/M	No
Get Telco Alarm Location	3-95	PICMG	39h		O/M	No
Set FRU Extracted	3-25	PICMG	3Ah		M	No

Table 4-15:AMC.0 Carrier Commands for IPMC

	IPMI Spec. section	NetFn	CMD	IPMI BMC req.	Carrier IPMC req.	Kontron support on IPMC
AMC	AMC.0 Table					
Set AMC Port State	Table 3-27	PICMG	19h		O/M	Yes
Get AMC Port State	Table 3-28	PICMG	1Ah		O/M	Yes
Set Clock State	Table 3-44	PICMG	2Ch		O/M	Yes
Get Clock State	Table 3-45	PICMG	2Dh		O/M	Yes

Table 4-16:HPM Commands

	IPMI Spec. section	NetFn	CMD	IPMI BMC req.	Carrier IPMC req.	Kontron support on IPMC
HPM						
Get Target Upgrade Capabilities						Yes
Get Component Properties						Yes
Abort Firmware Upgrade						Yes
Initiate Upgrade Action						Yes
Upload Firmware Block						Yes
Finish Firmware Upload						Yes
Get Upgrade Status						Yes
Activate Firmware						Yes
Query Self-Test Results						Yes
Query Rollback Status						Yes
Initiate Manual Rollback						Yes

4.3.2 Sensor Data Records

Information that describes the IPMC capabilities is provided through two mechanisms: capabilities commands and Sensor Data Records (SDRs). Capabilities commands are commands within the IPMI command set that return fields providing information on other commands and functions the controller can handle.

Sensor Data Records are data records containing information about the type and number of sensors in the platform, sensor threshold support, event generation capabilities, and information on what types of readings the sensor provides. The primary purpose of Sensor Data Records is to describe the sensor configuration of the hardware management subsystem to system software.

The IPMC are required to maintain Device Sensor Data Records for the sensors and objects they manage. Access methods for the Device SDR entries are described in the [IPMI 2.0] specification, Section 35, "Sensor Device Commands."

After a FRU is inserted, the System Manager, using the Shelf Manager, may gather the various SDRs from the FRU's IPM Controller to learn the various objects and how to use them. The System Manager uses the "Sensor Device Commands" to gather this information. Thus, commands, such as "Get Device SDR Info" and "Get Device SDR," which are optional in the IPMI specification, are mandatory in AdvancedTCA systems.

Most of the current Shelf Manager implementation gathers the individual Device Sensor Data Records of each FRU into a centralized SDR Repository. This SDR Repository may exist in either the Shelf Manager or System Manager. If the Shelf Manager implements the SDR Repository on-board, it shall also respond to "SDR Repository" commands.

This duplication of SDR repository commands creates sometime some confusion among AdvancedTCA users. This is mandatory for IPMC to support the Sensor Device Commands for IPMC built-in SDR as described in the [IPMI 2.0] specification, Section 35, "Sensor Device Commands." For the ShMC, the same set of commands for the centralized SDR Repository must be supported but they are described in the [IPMI 2.0] specification, Section 33, "SDR Repository Commands."

4.3.2.1 IPMC Sensors

Table 4-17: IPMC Sensors

ID	Sensor Name	Sensor Class	Description (Sensor Type, Event trigger)
0	FRU0 Hot Swap	Discrete	ATCA Board FRU Hot Swap Sensor for FRU 0 (Front Board) Sensor type code = F0h PICMG Hot Swap Event Reading type code = 6Fh Sensor specific See PICMG 3.0 R3.0 Table 3-22, "FRU Hot Swap event message"
1	FRU1 Hot Swap	Discrete	ATCA Board FRU Hot Swap Sensor for FRU 1 (AMC B1) Sensor type code = F0h PICMG Hot Swap Event Reading type code = 6Fh Sensor specific See PICMG 3.0 R3.0 Table 3-22, "FRU Hot Swap event message"
2	FRU2 Hot Swap	Discrete	ATCA Board FRU Hot Swap Sensor for FRU 2 (RTM) Sensor type code = F0h PICMG Hot Swap Event Reading type code = 6Fh Sensor specific See PICMG 3.0 R3.0 Table 3-22, "FRU Hot Swap event message"
3	FRU3 Hot Swap	Discrete	ATCA Board FRU Hot Swap Sensor for FRU 3 (RTM Disk) Sensor type code = F0h PICMG Hot Swap Event Reading type code = 6Fh Sensor specific See PICMG 3.0 R3.0 Table 3-22, "FRU Hot Swap event message"
4	FRU0 Reconfig	Discrete	Sensor Population Change on Carrier Sensor type = 12h System Event Event Reading type code = 6Fh Sensor specific, only offset 0 is used -see AMC.0 R2.0 for event trigger -see IPMI v1.5 table 36.3, Sensor type code 12h for sensor definition
5	Temp -48V A Feed	Threshold	DC Feed A Input Temperature (Degrees) Sensor type = 01h temperature Event Reading type code = 01h threshold based see IPMI v1.5 section 29.13.3 for threshold based event
6	Temp -48V B Feed	Threshold	DC Feed B Input Temperature (Degrees) Sensor type = 01h temperature Event Reading type code = 01h threshold based see IPMI v1.5 section 29.13.3 for threshold based event
7	Temp Mez 12V Out	Threshold	DC Feed 12V Out Temperature (Degrees) Sensor type = 01h temperature Event Reading type code = 01h threshold based see IPMI v1.5 section 29.13.3 for threshold based event
8	Temp VDDQ	Threshold	VDDQ Temperature (Degrees) Sensor type = 01h temperature Event Reading type code = 01h threshold based see IPMI v1.5 section 29.13.3 for threshold based event
9	Temp Vcore	Threshold	Vcore Switcher Temperature (Degrees) Sensor type = 01h temperature Event Reading type code = 01h threshold based see IPMI v1.5 section 29.13.3 for threshold based event
10	Temp IPMC	Threshold	H8S2472 IPM Controller Temperature (Degrees) Sensor type = 01h temperature Event Reading type code = 01h threshold based see IPMI v1.5 section 29.13.3 for threshold based event
11	Temp IOH	Threshold	I/O Hub (IOH) Chipset Temperature (Degrees) Sensor type = 01h temperature Event Reading type code = 01h threshold based see IPMI v1.5 section 29.13.3 for threshold based event

ID	Sensor Name	Sensor Class	Description (Sensor Type, Event trigger)
12	Temp ICH	Threshold	I/O Controller Hub (ICH) Chipset Temperature (Degrees) Sensor type = 01h temperature Event Reading type code = 01h threshold based see IPMI v1.5 section 29.13.3 for threshold based event
13	Temp Mngt Lan	Threshold	Management Ethernet Controller Temperature (Degrees) Sensor type = 01h temperature Event Reading type code = 01h threshold based see IPMI v1.5 section 29.13.3 for threshold based event
14	Temp BI Lan	Threshold	Base Interface Ethernet Controller Temperature (Degrees) Sensor type = 01h temperature Event Reading type code = 01h threshold based see IPMI v1.5 section 29.13.3 for threshold based event
15	Temp FI Lan	Threshold	Fabric Interface Ethernet Controller Temperature (Degrees) Sensor type = 01h temperature Event Reading type code = 01h threshold based see IPMI v1.5 section 29.13.3 for threshold based event
16	Temp Bay Inlet	Threshold	AMC B1 Inlet Temperature (Degrees) Sensor type = 01h temperature Event Reading type code = 01h threshold based see IPMI v1.5 section 29.13.3 for threshold based event
17	Temp CPU	Threshold	CPU Temperature (Degrees) Sensor type = 01h temperature Event Reading type code = 01h threshold based see IPMI v1.5 section 29.13.3 for threshold based event
18	Temp DIMM#1	Threshold	DIMM#1 Temperature (Degrees) Sensor type = 01h temperature Event Reading type code = 01h threshold based see IPMI v1.5 section 29.13.3 for threshold based event
19	Temp DIMM#2	Threshold	DIMM#2 Temperature (Degrees) Sensor type = 01h temperature Event Reading type code = 01h threshold based see IPMI v1.5 section 29.13.3 for threshold based event
20	Temp DIMM#3	Threshold	DIMM#3 Temperature (Degrees) Sensor type = 01h temperature Event Reading type code = 01h threshold based see IPMI v1.5 section 29.13.3 for threshold based event
21	Temp DIMM#4	Threshold	DIMM#4 Temperature (Degrees) Sensor type = 01h temperature Event Reading type code = 01h threshold based see IPMI v1.5 section 29.13.3 for threshold based event
22	Temp DIMM#5	Threshold	DIMM#5 Temperature (Degrees) Sensor type = 01h temperature Event Reading type code = 01h threshold based see IPMI v1.5 section 29.13.3 for threshold based event
23	Temp DIMM#6	Threshold	DIMM#6 Temperature (Degrees) Sensor type = 01h temperature Event Reading type code = 01h threshold based see IPMI v1.5 section 29.13.3 for threshold based event
24	Temp Disk	Threshold	Disk Temperature (Degrees) Sensor type = 01h temperature Event Reading type code = 01h threshold based see IPMI v1.5 section 29.13.3 for threshold based event
25	Brd Input Power	Threshold	Power consumption in watts of the complete blade (including managed FRU) Sensor type = 0Bh Other Unit-Based Sensor (Watt) Event Reading type code = 01h threshold base see IPMI v1.5 section 29.13.3 for threshold based event

ID	Sensor Name	Sensor Class	Description (Sensor Type, Event trigger)
26	AMC Power	Threshold	FRU 1 (AMC B1) Power consumption in watts Sensor type = 0Bh Other Unit-Based Sensor (Watt) Event Reading type code = 01h threshold base see IPMI v1.5 section 29.13.3 for threshold based event
27	RTM Power	Threshold	FRU 2 (RTM) + FRU 3 (RTM's disk) Power consumption in watts Sensor type = 0Bh Other Unit-Based Sensor (Watt) Event Reading type code = 01h threshold base see IPMI v1.5 section 29.13.3 for threshold based event
28	Vcore Power	Threshold	Vcore Power consumption in watts Sensor type = 0Bh Other Unit-Based Sensor (Watt) Event Reading type code = 01h threshold based see IPMI v1.5 section 29.13.3 for threshold based event
29	Vddq Power	Threshold	Vddq Power consumption in watts Sensor type = 0Bh Other Unit-Based Sensor (Watt) Event Reading type code = 01h threshold based see IPMI v1.5 section 29.13.3 for threshold based event
30	Vcc Mez Hold-UP	Threshold	Voltage on power mezzanine Vcc Hold-UP Sensor type = 02h voltage Event Reading type code = 01h threshold based see IPMI v1.5 section 29.13.3 for threshold based event
31	Vcc +1.0V SUS	Threshold	Voltage on board 1.0V suspend (management) power supply Sensor type = 02h voltage Event Reading type code = 01h threshold based see IPMI v1.5 section 29.13.3 for threshold based event
32	Vcc +1.2V SUS	Threshold	Voltage on board 1.2V suspend (management) power supply (Volts) Sensor type = 02h voltage Event Reading type code = 01h threshold based see IPMI v1.5 section 29.13.3 for threshold based event
33	Vcc +1.8V SUS	Threshold	Voltage on board 1.8V suspend (management) power supply (Volts) Sensor type = 02h voltage Event Reading type code = 01h threshold based see IPMI v1.5 section 29.13.3 for threshold based event
34	Vcc +3.3V SUS	Threshold	Voltage on board 3.3V suspend (management) power supply (Volts) Sensor type = 02h voltage Event Reading type code = 01h threshold based see IPMI v1.5 section 29.13.3 for threshold based event
35	Vcc +5V SUS	Threshold	Voltage on board 5V suspend (management) power supply (Volts) Sensor type = 02h voltage Event Reading type code = 01h threshold based see IPMI v1.5 section 29.13.3 for threshold based event
36	Vcc +12V SUS	Threshold	Voltage on board 12V suspend (management) power supply (Volts) Sensor type = 02h voltage Event Reading type code = 01h threshold based see IPMI v1.5 section 29.13.3 for threshold based event
37	Vcc Vtt	Threshold	Voltage on board Vtt payload power supply (Volts) Sensor type = 02h voltage Event Reading type code = 01h threshold based see IPMI v1.5 section 29.13.3 for threshold based event
38	Vcc VttDdr	Threshold	Voltage on board Vtt Ddr payload power supply (Volts) Sensor type = 02h voltage Event Reading type code = 01h threshold based see IPMI v1.5 section 29.13.3 for threshold based event
39	Vcc Vcore	Threshold	Voltage on board Vcore payload power supply (Volts) Sensor type = 02h voltage Event Reading type code = 01h threshold based see IPMI v1.5 section 29.13.3 for threshold based event

ID	Sensor Name	Sensor Class	Description (Sensor Type, Event trigger)
40	Vcc +1.1V	Threshold	Voltage on board 1.1V payload power supply (Volts) Sensor type = 02h voltage Event Reading type code = 01h threshold based see IPMI v1.5 section 29.13.3 for threshold based event
41	Vcc +1.2V	Threshold	Voltage on board 1.2V payload power supply (Volts) Sensor type = 02h voltage Event Reading type code = 01h threshold based see IPMI v1.5 section 29.13.3 for threshold based event
42	Vcc +1.5V	Threshold	Voltage on board 1.5V payload power supply (Volts) Sensor type = 02h voltage Event Reading type code = 01h threshold based see IPMI v1.5 section 29.13.3 for threshold based event
43	Vcc +1.8V	Threshold	Voltage on board 1.8V payload power supply (Volts) Sensor type = 02h voltage Event Reading type code = 01h threshold based see IPMI v1.5 section 29.13.3 for threshold based event
44	Vcc +3.3V	Threshold	Voltage on board 3.3V payload power supply (Volts) Sensor type = 02h voltage Event Reading type code = 01h threshold based see IPMI v1.5 section 29.13.3 for threshold based event
45	Vcc +5V	Threshold	Voltage on board 5V payload power supply (Volts) Sensor type = 02h voltage Event Reading type code = 01h threshold based see IPMI v1.5 section 29.13.3 for threshold based event
46	Vcc +2.5V REF	Threshold	Voltage on board 2.5V reference power supply (Volts) Sensor type = 02h voltage Event Reading type code = 01h threshold based see IPMI v1.5 section 29.13.3 for threshold based event
47	Vcc +1.8V CPU	Threshold	Voltage on board 1.8V CPU power supply (Volts) Sensor type = 02h voltage Event Reading type code = 01h threshold based see IPMI v1.5 section 29.13.3 for threshold based event
48	Vcc Vddq	Threshold	Voltage on board Vddq payload power supply (Volts) Sensor type = 02h voltage Event Reading type code = 01h threshold based see IPMI v1.5 section 29.13.3 for threshold based event
49	Vcc -48V A Feed	Threshold	Voltage on -48v feed A board input power supply (Volts) Sensor type = 02h voltage Event Reading type code = 01h threshold based see IPMI v1.5 section 29.13.3 for threshold based event
50	Vcc -48V B Feed	Threshold	Voltage on -48v feed B board input power supply (Volts) Sensor type = 02h voltage Event Reading type code = 01h threshold based see IPMI v1.5 section 29.13.3 for threshold based event
51	Feed A/B Status	Discrete	Feed A/B Redundancy Status. Sensor type = 08h Power Supply Event Reading type code = 0Bh Discrete (Redundancy State), only offset 0,1 are used, see IPMI v1.5 table 36.2, event reading type code 0Bh for sensor definition
52	DIMM#1 SPD Pres	Discrete	DIMM#1 Temperature Sensor Presence Sensor type = 25h Entity Presence, Event Reading type code = 6Fh Sensor specific, only offset 0,1 are used, -see IPMI v1.5 table 36.3, Sensor type code 25h (Entity Presence) for sensor definition
53	DIMM#2 SPD Pres	Discrete	DIMM#2 Temperature Sensor Presence Sensor type = 25h Entity Presence, Event Reading type code = 6Fh Sensor specific, only offset 0,1 are used, -see IPMI v1.5 table 36.3, Sensor type code 25h (Entity Presence) for sensor definition
54	DIMM#3 SPD Pres	Discrete	DIMM#3 Temperature Sensor Presence Sensor type = 25h Entity Presence, Event Reading type code = 6Fh Sensor specific, only offset 0,1 are used, -see IPMI v1.5 table 36.3, Sensor type code 25h (Entity Presence) for sensor definition

ID	Sensor Name	Sensor Class	Description (Sensor Type, Event trigger)
55	DIMM#4 SPD Pres	Discrete	DIMM#4 Temperature Sensor Presence Sensor type = 25h Entity Presence, Event Reading type code = 6Fh Sensor specific, only offset 0,1 are used, -see IPMI v1.5 table 36.3, Sensor type code 25h (Entity Presence) for sensor definition
56	DIMM#5 SPD Pres	Discrete	DIMM#5 Temperature Sensor Presence Sensor type = 25h Entity Presence, Event Reading type code = 6Fh Sensor specific, only offset 0,1 are used, -see IPMI v1.5 table 36.3, Sensor type code 25h (Entity Presence) for sensor definition
57	DIMM#6 SPD Pres	Discrete	DIMM#6 Temperature Sensor Presence Sensor type = 25h Entity Presence, Event Reading type code = 6Fh Sensor specific, only offset 0,1 are used, -see IPMI v1.5 table 36.3, Sensor type code 25h (Entity Presence) for sensor definition
58	Fuse-Pres A Feed	Discrete	Fuse presence and fault detection -48 V on supply A Sensor type = 08h Power Supply, Event Reading type code = 6Fh Sensor specific, only offset 0,1 are used, -see IPMI v1.5 table 36.3, Sensor type code 08h for sensor definition
59	Fuse-Pres B Feed	Discrete	Fuse presence and fault detection -48 V on supply B Sensor type = 08h Power Supply, Event Reading type code = 6Fh Sensor specific, only offset 0,1 are used, -see IPMI v1.5 table 36.3, Sensor type code 08h for sensor definition
60	Fuse-RTN A Feed	Discrete	Fuse presence and fault detection RTN (Return) on supply A Sensor type = 08h Power Supply, Event Reading type code = 6Fh Sensor specific, only offset 0,1 are used, -see IPMI v1.5 table 36.3, Sensor type code 08h for sensor definition
61	Fuse-RTN B Feed	Discrete	Fuse presence and fault detection RTN (Return) on supply B Sensor type = 08h Power Supply, Event Reading type code = 6Fh Sensor specific, only offset 0,1 are used, -see IPMI v1.5 table 36.3, Sensor type code 08h for sensor definition
62	Fuse-Earl A Feed	Discrete	Fuse presence and fault detection on Early -48V supply A Sensor type = 08h Power Supply, Event Reading type code = 6Fh Sensor specific, only offset 0,1 are used, -see IPMI v1.5 table 36.3, Sensor type code 08h for sensor definition
63	Fuse-Earl B Feed	Discrete	Fuse presence and fault detection on Early -48V supply B Sensor type = 08h Power Supply, Event Reading type code = 6Fh Sensor specific, only offset 0,1 are used, -see IPMI v1.5 table 36.3, Sensor type code 08h for sensor definition
64	Power State	Discrete	Board Power State Sensor type = D0h Kontron OEM Power State Sensor Event Reading type code = 6Fh Sensor specific -see OEM sensor table, Sensor type code D1h for sensor definition
65	Power Good	Discrete	Actual power good status Sensor type = 08h Power Supply Event Reading type code = 77h OEM -see OEM sensor table, Event/Reading type code 77h for sensor definition
66	Power Good Event	Discrete	Power good status event that occur since the last power on or reset. Sensor type = 08h Power Supply Event Reading type code = 77h OEM -see OEM sensor table, Event/Reading type code 77h for sensor definition
67	Board Reset	Discrete	Board reset type and sources Sensor type = CFh OEM (Kontron Reset Sensor), Event Reading type code = 03h Digital Discrete offset 0,1 are used, -see OEM sensor table, Sensor type code CFh for sensor definition
68	POST Value	Discrete	Show current postcode value. No event generated by this sensor. Sensor type = C6h OEM (Kontron POST value sensor), Event Reading type code = 6Fh Sensor specific, offset 0 to 7 and 14 are used, -see OEM sensor table, Sensor type code C6h for sensor definition
69	Boot Error	Discrete	Boot Error Sensor Type = 1Eh Boot Error Reading type code = 6Fh Sensor Specific, only offset 0 is used, -see IPMI v1.5 table 36.3, Sensor type code 1Eh for sensor definition
70	POST Error	Discrete	CPU Power On Self Test Error Sensor type = 0Fh System Firmware Progress Event Reading type code = 6Fh Sensor specific, only offset 0 is used, -see IPMI v1.5 table 36.3, Sensor type code 0Fh (System Firmware Progress) for sensor definition
71	Critical Int	Discrete	Critical Interrupt Sensor type = 13h Critical Interrupt, Event Reading type code = 6Fh Critical Interrupt offset 0,4,5 are used, -see IPMI v1.5 table 36.3, Sensor type code 13h for sensor definition

ID	Sensor Name	Sensor Class	Description (Sensor Type, Event trigger)
72	Memory	Discrete	Memory Status Sensor type = 0Ch Memory Event Reading type code = 6Fh Sensor specific, offset 0,1,3,4,5 are used, -see IPMI v1.5 table 36.3, Sensor type code 0Ch for sensor definition
73	CMOS Mem Size	Discrete	POST Memory Resize, Indicates if CMOS memory size if wrong Sensor type = 0Eh, POST Memory Resize Event Reading type code = 03h Digital Discrete offset 0,1 are used, -see IPMI v1.5 table 36.3, Event/Reading type code 03h for sensor definition
74	CMOS Passwd	Discrete	CMOS Password Failure Sensor type = 06h Platform Security Violation Attempt, Event Reading type code = 6Fh Sensor Specific offset 1 and 4 are used, -see IPMI v1.5 table 36.3, Sensor type code 06h for sensor definition
75	CPU Status	Discrete	Processor Status Sensor type = 07h Processor, Event Reading type code = 6Fh Sensor Specific offset 0,1,5 are used, -see IPMI v1.5 table 36.3, Sensor type code 07h for sensor definition
76	Bios Flash 0	Discrete	BIOS Flash 0 Status Sensor type = 1Eh Boot Error Event Reading type code = 6Fh Sensor specific, only offset 3 is used, -see IPMI v1.5 table 36.3, Sensor type code 1Eh (Boot Error) for sensor definition
77	Bios Flash 1	Discrete	BIOS Flash 1 Status Sensor type = 1Eh Boot Error Event Reading type code = 6Fh Sensor specific, only offset 3 is used, -see IPMI v1.5 table 36.3, Sensor type code 1Eh (Boot Error) for sensor definition
78	ACPI State	Discrete	Advance Configuration and Power Interface State Sensor type = 22h System ACPI Power State Event Reading type code = 6Fh Sensor specific, offset 0,4,5,10,11,12,14 are used. -see IPMI v1.5 table 36.3, Sensor type code 22h (ACPI Power State) for sensor definition
79	IPMI Watchdog	Discrete	IPMI Watchdog (payload watchdog) Sensor type = 23h Watchdog 2, Event Reading type code = 6Fh Sensor specific, offset 0,1,2,3,8 are used, -see IPMI v1.5 table 36.3, Sensor type code 23h (Watchdog 2) for sensor definition
80	CLK3 Control	Discrete	Clock Resource Sensor Sensor type = D0h, Kontron OEM Clock Resource Control Sensor Event Reading type code = 6Fh Sensor specific, offset 0,1,2,3,8 are used, -see OEM table, Sensor type code D0h (Kontron OEM Clock Resource Control Sensor) for sensor definition
81	FW Ver Change	Discrete	Firmware Change Detection Sensor type = 2Bh Version Change Event Reading type code = 6Fh Sensor specific, -see IPMI v1.5 table 36.3, Sensor type code 2Bh (Version Change) for sensor definition
82	Health Error	Discrete	General health status, Aggregation of critical sensor. This list is flexible and could be adjust based on customer requirements. Sensor type = 24h Platform Alert, Event Reading type code = 03h Digital Discrete offset 0,1 are used, -see IPMI v1.5 table 36.3, Sensor type code 24h for sensor definition
83	IPMB0 Link State	Discrete	IPMB-0 fault detection sensor Sensor type = F1h PICMG Physical IPMB-0 Event Reading type code = 6Fh Sensor specific - See PICMG 3.0 R3.0 Table 3-69, "Physical IPMB-0 event message"
84	FRU0 IPMBL State	Discrete	IPMB-L branch from FRU0 fault detection sensor. Sensor type = C3h OEM (Kontron OEM IPMB-L link state), Event Reading type code = 6Fh Sensor specific, offset 2 and 3 are used, -see OEM table, Sensor type code C3h (Kontron OEM IPMB-L Link State) for sensor definition
85	FRU1 IPMBL State	Discrete	IPMB-L branch from FRU1 fault detection sensor. Sensor type = C3h OEM (Kontron OEM IPMB-L link state), Event Reading type code = 6Fh Sensor specific, offset 2 and 3 are used, -see OEM table, Sensor type code C3h (Kontron OEM IPMB-L Link State) for sensor definition
86	FRU2 IPMBL State	Discrete	IPMB-L branch from FRU2 fault detection sensor. Sensor type = C3h OEM (Kontron OEM IPMB-L link state), Event Reading type code = 6Fh Sensor specific, offset 2 and 3 are used, -see OEM table, Sensor type code C3h (Kontron OEM IPMB-L Link State) for sensor definition

ID	Sensor Name	Sensor Class	Description (Sensor Type, Event trigger)
87	FRU Over Icc	Discrete	FRU Over Current Sensor Sensor type = CBh OEM (Kontron OEM FRU Over Current) Event Reading type code = 03h Digital Discrete offset 0,1 are used, -see OEM table, Sensor type code CBh (Kontron OEM FRU Overcurrent) for sensor definition
88	FRU Sensor Error	Discrete	FRU Error during external FRU Sensor discovery Sensor type = CCh OEM (Kontron OEM FRU sensor error) Event Reading type code = 03h Digital Discrete offset 0,1 are used, -see OEM table, Sensor type code CCh (Kontron OEM FRU sensor error) for sensor definition
89	FRU Pwr Denied	Discrete	FRU Power Denial Detection Sensor type = CDh OEM (Kontron FRU Power denied) Event Reading type code = 03h Digital Discrete offset 0,1 are used -see OEM table, Sensor type code CDh (Kontron OEM FRU Power Denied) for sensor definition
90	FRU MngtPwr Fail	Discrete	FRU Management Power Fail Sensor type = D2h OEM (Kontron FRU Management Power Fail) Event Reading type code = 03h Digital Discrete offset 0,1 are used - see OEM table, Sensor type code D2h (Kontron OEM FRU Management Power Fail) for sensor definition
91	FRU0 Agent	Discrete	FRU Information Agent - FRU0 Data Error Detection Sensor type = C5h OEM (Kontron FRU Info Agent) Event Reading type code = 0Ah Generic Discrete, offset 6,8 are used -see OEM table, Sensor type code C5h (Kontron OEM FRU Information Agent) for sensor definition
92	FRU1 Agent	Discrete	FRU Information Agent - FRU1 Data Error Detection Sensor type = C5h OEM (Kontron FRU Info Agent), Event Reading type code = 0Ah Generic Discrete, offset 6,8 are used -see OEM table, Sensor type code C5h (Kontron OEM FRU Information Agent) for sensor definition
93	FRU2 Agent	Discrete	FRU Information Agent - FRU2 Data Error Detection Sensor type = C5h OEM (Kontron FRU Info Agent), Event Reading type code = 0Ah Generic Discrete, offset 6,8 are used -see OEM table, Sensor type code C5h (Kontron OEM FRU Information Agent) for sensor definition
94	FRU3 Agent	Discrete	FRU Information Agent - FRU3 Data Error Detection Sensor type = C5h OEM (Kontron FRU Info Agent), Event Reading type code = 0Ah Generic Discrete, offset 6,8 are used -see OEM table, Sensor type code C5h (Kontron OEM FRU Information Agent) for sensor definition
95	EventRcv ComLost	Discrete	Detects communication with the event receiver (ShMc) has been lost Sensor type = 1Bh Cable/Interconnect, Event Reading type code = 03h Digital Discrete - see IPMI v1.5 table 36.2 and table 36.3 for sensor definition
96	IPMC Reboot	Discrete	IPMC reboot detection Sensor type = 24h Platform Alert, Event Reading type code = 03h Digital Discrete offset 0,1 are used -see IPMI v1.5 table 36.3, Sensor type code 24h for sensor definition
97	IPMC FwUp	Discrete	Kontron OEM IPMC firmware upgrade Status Sensor type = C7h OEM (Kontron OEM MC firmware upgrade Status) Event Reading type code = 6Fh Sensor specific, offset 0,1 are used -see OEM table, Sensor type code C7h (Kontron OEM MC firmware upgrade Status) for sensor definition
98	IPMC Storage Err	Discrete	Management sub-system health: non volatile memory error. Sensor type = 28h Management Subsystem Health Event Reading type code = 6Fh Sensor specific, only offset 1 is used, -see IPMI v1.5 table 36.3, Sensor type code 28h for sensor definition
99	IPMC SEL State	Discrete	Specify if the status of the SEL (Cleared/Almost Full/Full) Sensor type = 10h Event Logging Disable Event Reading type code = 6Fh Sensor specific, only offset 2,4,5 are used, -see IPMI v1.5 table 36.3, Sensor type code 10h (Event Log Disable) for sensor definition

ID	Sensor Name	Sensor Class	Description (Sensor Type, Event trigger)
100	ME Availability	Discrete	Provides status on the chipset Management Engine Sensor type = 28h Management Subsystem Health Event Reading type code = 0Ah Generic Discrete, offset 2,6,8 are used see IPMI v1.5 table 36.2, event reading type code 0Ah for sensor definition
101	Jumper Status	Discrete	Reflects on-board jumper presence Sensor type = D3h OEM (Kontron OEM Jumper Status) Event Reading type code = 6Fh Sensor specific, offsets 0 to 14 are used -see OEM table, Sensor type code D3h (Kontron OEM Jumper Status) for sensor definition
102	IPMI Info-1	Discrete	Internal Management Controller firmware diagnostic Sensor type = C0h Kontron OEM Firmware Info Event Reading type code = 70h Kontron OEM Internal Diagnostic -see OEM table, Sensor type code C0h (Kontron OEM Firmware Info) for sensor definition and Event/Reading type code 70h (Kontron OEM Internal Diagnostic)
103	IPMI Info-2	Discrete	Internal Management Controller firmware diagnostic Sensor type = C0h Kontron OEM Firmware Info Event Reading type code = 75h Kontron OEM Internal Diagnostic -see OEM table, Sensor type code C0h (Kontron OEM Firmware Info) for sensor definition and Event/Reading type code 70h (Kontron OEM Internal Diagnostic)

4.3.2.2 IPMC Health Indicator Sensor Aggregation

The following table shows the sensors involved in the health sensor aggregation.

Table 4-18: IPMC Health Indicator Sensor Aggregation Table

IPMI sensor ID	Sensor Name
5	Temp -48V A Feed
6	Temp -48V B Feed
7	Temp Mez 12V Out
8	Temp VDDQ
9	Temp Vcore
10	Temp IPMC
11	Temp IOH
12	Temp ICH
13	Temp Mngt Lan
14	Temp BI Lan
15	Temp FI Lan
16	Temp Bay Inlet
17	Temp CPU
18	Temp DIMM#1
19	Temp DIMM#2
20	Temp DIMM#3
21	Temp DIMM#4
22	Temp DIMM#5
23	Temp DIMM#6
25	Brd Input Power

IPMI sensor ID	Sensor Name
26	AMC Power
27	RTM Power
28	Vcore Power
29	Vddq Power
30	Vcc Mez Hold-UP
31	Vcc +1.0V SUS
32	Vcc +1.2V SUS
33	Vcc +1.8V SUS
34	Vcc +3.3V SUS
35	Vcc +5V SUS
36	Vcc +12V SUS
37	Vcc Vtt
38	Vcc VttDdr
39	Vcc Vcore
40	Vcc +1.1V
41	Vcc +1.2V
42	Vcc +1.5V
43	Vcc +1.8V
44	Vcc +3.3V
45	Vcc +5V
46	Vcc +2.5V REF
47	Vcc +1.8V CPU
48	Vcc Vddq
49	Vcc -48V A Feed
50	Vcc -48V B Feed
51	Feed A/B Status
58	Fuse-Pres A Feed
59	Fuse-Pres B Feed
60	Fuse-RTN A Feed
61	Fuse-RTN B Feed
62	Fuse-Earl A Feed
63	Fuse-Earl B Feed
65	Power Good
66	Power Good Event
67	Board Reset
70	POST Error
71	Critical Int
72	Memory
73	CMOS Mem Size
74	CMOS Passwd

IPMI sensor ID	Sensor Name
75	CPU Status
76	Bios Flash 0
77	Bios Flash 1
79	IPMI Watchdog

4.3.3 FRU Information

Table 4-19:Board Information Area

Board Information Area	
Field Description	Value (hex)
Format Version	0x01
Board Area Length	*Calculated
Language code	0x19
Manufacturing Date / Time	*Based on mfg. date
Board Manufacturer type/length	*Calculated
Board Manufacturer	"KONTRON "
Board Name type/length	*Calculated
Board Name	"AT8050"
Board Serial Number type/length	*Calculated
Board Serial Number	*10 digits serial number
Board Part Number type/length	*Calculated
Board Part Number	T5007AA#_R-ZZZZ (R= Board revision) (Z=config. 00000 = No DDR3, 00001 = 12GB DDR3)
FRU File ID type/length	*Calculated
FRU File ID	"FRU5007-XX" (XX=template version)
No more fields	0xC1
Padding	None
Board Area Checksum	*Calculated

Table 4-20:Product Information Area

Product Information Area	
Field Description	Value (hex)
Format Version	0x01
Product Area Length	*Calculated
Language code	0x19
Product Manufacturer type/length	*Calculated
Product Manufacturer	"KONTRON "
Product Name type/length	*Calculated
Product Name	"AT8050"
Product Part Number type/length	*Calculated
Product Part Number	T5007AA#_R-ZZZZ (R= Board revision) (Z=config. 00000 = No DDR3, 00001 = 12GB DDR3)
Product Version type/length	*Calculated
Product Version	R (R=revision)
Product Serial Number type/length	*Calculated
Product Serial Number	XXXXXXXX
Product Part Number type/length	*Calculated
Asset Tag type/length	0xCF
Asset Tag	" _____ "
FRU File ID type/length	*Calculated
FRU File ID	"FRU5007-XX" (XX=template version)
No more fields	0xC1
Padding	None
Board Area Checksum	*Calculated

* Variable X, may change on revisions.

4.3.3.1 ATCA Board E-Keying Information

The board e-keying information contains PICMG 3.0 R3.0 defined channel and link descriptors required for matchmaking computation by the ShMC.

The following table gives the E-Keying capabilities of the board, as they appear in the FRU data.

Table 4-21: E-Keying capabilities of the board

Field	Value
Record Type ID	C0h
Record Format Version	02h
Record Length	*Calculated
Record Checksum	*Calculated
Header Checksum	*Calculated
Record Type ID	C0h
Record format version	02h
Manufacturer ID	00315Ah (PICMG Record ID)
PICMG Record ID	14h (Board Point-To-Point Connectivity Record)
Record Format Version	00h
OEM GUID Count	01h
OEM GUID [F0]	OEM PCIe x4 + CLK Update Channel
Link Descriptor	00001101h
Link Grouping ID (Bits 31-24)	0h : Single-Channel link
Link Type Extension (Bits 23-20)	0h : None
Link Type (Bits 19-12)	01h : PICMG 3.0 Base Interface 10/100/1000 BASE-T
Link Designator (Bits 11-0)	101h : Base Interface, Channel 1, Port 0
Link Descriptor	00001102h
Link Grouping ID (Bits 31-24)	0h : Single-Channel link
Link Type Extension (Bits 23-20)	0h : None
Link Type (Bits 19-12)	01h : PICMG 3.0 Base Interface 10/100/1000 BASE-T
Link Designator (Bits 11-0)	102h : Base Interface, Channel 2, Port 0
Link Descriptor	00102F41h
Link Grouping ID (Bits 31-24)	0h : Single-Channel link
Link Type Extension (Bits 23-20)	1h : Fixed 10GBASE-BX4 [XAUI]
Link Type (Bits 19-12)	02h : PICMG 3.1 Ethernet Fabric Interface
Link Designator (Bits 11-0)	F41h : Fabric Interface, Channel 1, Port 0, 1, 2, 3
Link Descriptor	00002341h
Link Grouping ID (Bits 31-24)	0h : Single-Channel link
Link Type Extension (Bits 23-20)	0h : Fixed 1000Base-BX
Link Type (Bits 19-12)	02h : PICMG 3.1 Ethernet Fabric Interface
Link Designator (Bits 11-0)	341h : Fabric Interface, Channel 1, Port 0,1
Link Descriptor	00002141h
Link Grouping ID (Bits 31-24)	0h : Single-Channel link
Link Type Extension (Bits 23-20)	0h : Fixed 1000Base-BX
Link Type (Bits 19-12)	02h : PICMG 3.1 Ethernet Fabric Interface
Link Designator (Bits 11-0)	141h : Fabric Interface, Channel 1, Port 0
Link Descriptor	00102F42h
Link Grouping ID (Bits 31-24)	0h : Single-Channel link
Link Type Extension (Bits 23-20)	1h : Fixed 10GBASE-BX4 [XAUI]

Field	Value
Link Type (Bits 19-12)	02h : PICMG 3.1 Ethernet Fabric Interface
Link Designator (Bits 11-0)	F42h : Fabric Interface, Channel 2, Port 0, 1, 2, 3
Link Descriptor	00002342h
Link Grouping ID (Bits 31-24)	0h : Single-Channel link
Link Type Extension (Bits 23-20)	0h : Fixed 1000Base-BX
Link Type (Bits 19-12)	02h : PICMG 3.1 Ethernet Fabric Interface
Link Designator (Bits 11-0)	342h : Fabric Interface, Channel 2, Port 0,1
Link Descriptor	00002142h
Link Grouping ID (Bits 31-24)	0h : Single-Channel link
Link Type Extension (Bits 23-20)	0h : Fixed 1000Base-BX
Link Type (Bits 19-12)	02h : PICMG 3.1 Ethernet Fabric Interface
Link Designator (Bits 11-0)	142h : Fabric Interface, Channel 2, Port 0
Link Descriptor	000F0181h
Link Grouping ID (Bits 31-24)	0h : Single-Channel link
Link Type Extension (Bits 23-20)	0h : None
Link Type (Bits 19-12)	F0h : OEM PCIe x4 + CLK Update Channel
Link Designator (Bits 11-0)	181h : Update Channel Interface 1, Port 0 (all ten pairs)

4.3.3.2 AMC Carrier Activation and Carrier Information Table

The AMC slot power budget is included in the following table.

Table 4-22:AMC Carrier Activation and Carrier Information Table

Field	Value
Record Type ID	C0h
Record format version	02h
Record Length	*Calculated
Record Checksum	*Calculated
Header Checksum	*Calculated
Manufacturer ID	00315Ah
PICMG Record ID	17h (Carrier Activation And Current Management)
Record Format Version	00h
Maximum Internal Current	29h (4.1 A @ 12 V) => 49.2 Watts
Allowance for Module Activation Readiness	002h
Module Activation and Power Descriptor Count	01h
Carrier Activation and Power Descriptors.	7Ah, 22h, FFh
Local IPMB Address	7Ah
Maximum Module Current	29h (4.1 A @ 12 V) => 49.2 Watts
Reserved	FFh

The Carrier Information Table gives the Carrier AMC.0 specification version and the Carrier's AMC sites list.

Table 4-23: Carrier AMC.0

Field	Value
Record Type ID	C0h
Record format version	02h
Record Length	*Calculated
Record Checksum	*Calculated
Header Checksum	*Calculated
Manufacturer ID	00315Ah (PICMG Record ID)
PICMG Record ID	0x1A (Carrier Information Table)
Record Format Version	00h
AMC.0 Extension Version	02h (AMC.0 R2.0)
Carrier Site Number Count	01h
Carrier Site Number	05h

4.3.3.3 AMC Carrier Point-To-Point Connectivity Information

As defined in the AMC.0 specification, On-Carrier Device Ids are arbitrarily assigned to devices that implement E-Key governed links. Remote resources, such as AMCs, use predefined Ids corresponding to their Site Numbers. The following table gives the mapping between the devices and the corresponding Ids.

Table 4-24: Mapping between the devices and the corresponding Ids

Devices	Resource Id
Intel IOH PCI-Express Root Complex Port 3	00h
Intel IOH PCI-Express Root Complex Port 8	01h
Intel ICH10 SATA Controller	02h
Intel 82576EB NC (front/rear)	03h
Onboard Fabric Channel 1 Switch	04h
Onboard Fabric Channel 2 Switch	05h
FPGA Based UART	06h
RTM (On-Carrier Virtual Device for RTM)	07h
AMC B1 (AMC Site Number 5)	85h

The Carrier Point-To-Point Connectivity record gives the list of available point-to-point link paths between On-Carrier Devices and AMC Sites. The record's content is given by the following table.

Table 4-25: Record's content

Field	Value
Record Type ID	C0h
Record format version	02h
Record Length	*Calculated
Record Checksum	*Calculated
Header Checksum	*Calculated

Field	Value
Manufacturer ID	00315Ah (PICMG Record ID)
PICMG Record ID	18h (Carrier Point-To-Point Connectivity Record)
Record Format Version	00h
Point-To-Point AMC Resource Descriptor	
Local Resource ID	85h ->AMC Site 5 (AMC B1)
Point-To-Point Port Count	Dh
Point-to-Point Port Descriptor	000003h
Reserved (Bits 23-18)	0h
Local Port (Bits 13-17)	0h
Remote Port (Bit 12-8)	0h
Remote Resource ID (Bits 7-0)	03h ->Carrier, Device 3 (Intel 82576EB NC (front/rear))
Point-to-Point Port Descriptor	002103h
Reserved (Bits 23-18)	0h
Local Port (Bits 13-17)	1h
Remote Port (Bit 12-8)	1h
Remote Resource ID (Bits 7-0)	03h ->Carrier, Device 3 (Intel 82576EB NC (front/rear))
Point-to-Point Port Descriptor	004002h
Reserved (Bits 23-18)	0h
Local Port (Bits 13-17)	2h
Remote Port (Bit 12-8)	0h
Remote Resource ID (Bits 7-0)	02h -> Intel ICH SATA Controller
Point-to-Point Port Descriptor	004207h
Reserved (Bits 23-18)	0h
Local Port (Bits 13-17)	2h
Remote Port (Bit 12-8)	2h
Remote Resource ID (Bits 7-0)	07h -> Virtual On-Carrier Device 7 (RTM)
Point-to-Point Port Descriptor	006307h
Reserved (Bits 23-18)	0h
Local Port (Bits 13-17)	3h
Remote Port (Bit 12-8)	3h
Remote Resource ID (Bits 7-0)	07h -> Virtual On-Carrier Device 7 (RTM)
Point-to-Point Port Descriptor	008001h
Reserved (Bits 23-18)	0h
Local Port (Bits 13-17)	4h
Remote Port (Bit 12-8)	0h
Remote Resource ID (Bits 7-0)	01h ->Carrier, Device 1 (Intel IOH PCI-Express Root Complex Port 7)
Point-to-Point Port Descriptor	00a101h
Reserved (Bits 23-18)	0h

Field	Value
Local Port (Bits 13-17)	5h
Remote Port (Bit 12-8)	1h
Remote Resource ID (Bits 7-0)	01h ->Carrier, Device 1 (Intel IOH PCI-Express Root Complex Port 7)
Point-to-Point Port Descriptor	00c201h
Reserved (Bits 23-18)	0h
Local Port (Bits 13-17)	6h
Remote Port (Bit 12-8)	2h
Remote Resource ID (Bits 7-0)	01h ->Carrier, Device 1 (Intel IOH PCI-Express Root Complex Port 7)
Point-to-Point Port Descriptor	00e301h
Reserved (Bits 23-18)	0h
Local Port (Bits 13-17)	7h
Remote Port (Bit 12-8)	3h
Remote Resource ID (Bits 7-0)	01h ->Carrier, Device 1 (Intel IOH PCI-Express Root Complex Port 7)
Point-to-Point Port Descriptor	010804h
Reserved (Bits 23-18)	0h
Local Port (Bits 13-17)	8h
Remote Port (Bit 12-8)	8h
Remote Resource ID (Bits 7-0)	04h ->Carrier, Device 4 (Fabric Channel 1 via OnBoard Switch)
Point-to-Point Port Descriptor	012805h
Reserved (Bits 23-18)	0h
Local Port (Bits 13-17)	9h
Remote Port (Bit 12-8)	8h
Remote Resource ID (Bits 7-0)	05h ->Carrier, Device 5 (Fabric Channel 2 via OnBoard Switch)
Point-to-Point Port Descriptor	014704h
Reserved (Bits 23-18)	0h
Local Port (Bits 13-17)	Ah
Remote Port (Bit 12-8)	0h
Remote Resource ID (Bits 7-0)	04h ->Carrier, Device 4 (Fabric Channel 1 via OnBoard Switch)
Point-to-Point Port Descriptor	016705h
Reserved (Bits 23-18)	0h
Local Port (Bits 13-17)	Bh
Remote Port (Bit 12-8)	7h
Remote Resource ID (Bits 7-0)	05h ->Carrier, Device 5 (Fabric Channel 2 via OnBoard Switch)
Point-to-Point Port Descriptor	01ed07h
Reserved (Bits 23-18)	0h
Local Port (Bits 13-17)	Fh
Remote Port (Bit 12-8)	Dh

Field	Value
Remote Resource ID (Bits 7-0)	07h -> Virtual On-Carrier Device 7 (RTM)
Point-To-Point AMC Resource Descriptor	
Local Resource ID	07h -> Virtual On-Carrier Device 7 (RTM)
Point-To-Point Port Count	Bh
Point-to-Point Port Descriptor	000003h
Reserved (Bits 23-18)	0h
Local Port (Bits 13-17)	0h
Remote Port (Bit 12-8)	0h
Remote Resource ID (Bits 7-0)	03h ->Carrier, Device 3 (Intel 82576EB NC (front/rear))
Point-to-Point Port Descriptor	002103h
Reserved (Bits 23-18)	0h
Local Port (Bits 13-17)	1h
Remote Port (Bit 12-8)	1h
Remote Resource ID (Bits 7-0)	03h ->Carrier, Device 3 (Intel 82576EB NC (front/rear))
Point-to-Point Port Descriptor	004285h
Reserved (Bits 23-18)	0h
Local Port (Bits 13-17)	2h
Remote Port (Bit 12-8)	2h
Remote Resource ID (Bits 7-0)	85h ->AMC Site 5 (AMC B1)
Point-to-Point Port Descriptor	006385h
Reserved (Bits 23-18)	0h
Local Port (Bits 13-17)	3h
Remote Port (Bit 12-8)	3h
Remote Resource ID (Bits 7-0)	85h ->AMC Site 5 (AMC B1)
Point-to-Point Port Descriptor	008000h
Reserved (Bits 23-18)	0h
Local Port (Bits 13-17)	4h
Remote Port (Bit 12-8)	0h
Remote Resource ID (Bits 7-0)	00h ->Carrier, Device 0 (Intel IOH PCI-Express Root Complex Port 3)
Point-to-Point Port Descriptor	00a100h
Reserved (Bits 23-18)	0h
Local Port (Bits 13-17)	5h
Remote Port (Bit 12-8)	1h
Remote Resource ID (Bits 7-0)	00h ->Carrier, Device 0 (Intel IOH PCI-Express Root Complex Port 3)
Point-to-Point Port Descriptor	00c200h
Reserved (Bits 23-18)	0h
Local Port (Bits 13-17)	6h

Field	Value
Remote Port (Bit 12-8)	2h
Remote Resource ID (Bits 7-0)	00h ->Carrier, Device 0 (Intel IOH PCI-Express Root Complex Port 3)
Point-to-Point Port Descriptor	00e300h
Reserved (Bits 23-18)	0h
Local Port (Bits 13-17)	7h
Remote Port (Bit 12-8)	3h
Remote Resource ID (Bits 7-0)	00h ->Carrier, Device 0 (Intel IOH PCI-Express Root Complex Port 3)
Point-to-Point Port Descriptor	018102h
Reserved (Bits 23-18)	0h
Local Port (Bits 13-17)	Ch
Remote Port (Bit 12-8)	1h
Remote Resource ID (Bits 7-0)	02h ->Carrier, Device 2 (Intel ICH SATA Controller)
Point-to-Point Port Descriptor	01a006h
Reserved (Bits 23-18)	0h
Local Port (Bits 13-17)	Dh
Remote Port (Bit 12-8)	0h
Remote Resource ID (Bits 7-0)	06h ->Carrier, Device 6 (FPGA Based UART)
Point-to-Point Port Descriptor	01af85h
Reserved (Bits 23-18)	0h
Local Port (Bits 13-17)	Dh
Remote Port (Bit 12-8)	Fh
Remote Resource ID (Bits 7-0)	85h ->AMC Site 5 (AMC B1)

4.3.3.4 AMC Point-To-Point Connectivity Information

The following table gives AMC connectivity details for "Intel IOH PCI-Express Root Complex Port 3" (On-Carrier Device 0).

Table 4-26:AMC connectivity details for "Intel IOH PCI-Express Root Complex Port 3"

Field	Value
Record Type ID	C0h
Record format version	02h
Record Length	*Calculated
Record Checksum	*Calculated
Header Checksum	*Calculated
Manufacturer ID	00315Ah
PICMG Record ID	19h (AMC Point-To-Point Connectivity Record)
Record Format Version	00h

Field	Value
OEM GUID Count	0h
Record Type/Connected-device ID	00h(Carrier,Device 0->Intel IOH PCI-Express Root Complex Port 3)
AMC Channel Descriptor Count	01h
AMC Channel Descriptor	F18820h
Reserved (Bits 23-20)	0Fh
Lane 3 Port Number (Bits 19-15)	03h
Lane 2 Port Number (Bits 14-10)	02h
Lane 1 Port Number (Bits 9-5)	01h
Lane 0 Port Number (Bits 4-0)	00h
AMC Link Descriptor	FE00302f00h
Reserved (Bits 39-34)	3Fh
AMC Asymmetric Match (Bits 33-32)	02h (Provides a Secondary PCI Express Port)
Link Grouping ID (Bits 31-24)	00h (Single-Channel Link)
AMC Link Type Extension (Bits 23-20)	03h (Gen2 SSC)
AMC Link Type (Bits 19-12)	02h (AMC.1 PCI Express)
AMC Link Designator (Bits 11-0)	F00h: AMC Channel 0,Lane0,1,2,3
AMC Link Descriptor	FE00202f00h
Reserved (Bits 39-34)	3Fh
AMC Asymmetric Match (Bits 33-32)	02h (Provides a Secondary PCI Express Port)
Link Grouping ID (Bits 31-24)	00h (Single-Channel Link)
AMC Link Type Extension (Bits 23-20)	02h (Gen2 NO SSC)
AMC Link Type (Bits 19-12)	02h (AMC.1 PCI Express)
AMC Link Designator (Bits 11-0)	F00h: AMC Channel 0,Lane0,1,2,3
AMC Link Descriptor	FE00102f00h
Reserved (Bits 39-34)	3Fh
AMC Asymmetric Match (Bits 33-32)	02h (Provides a Secondary PCI Express Port)
Link Grouping ID (Bits 31-24)	00h (Single-Channel Link)
AMC Link Type Extension (Bits 23-20)	01h (Gen1 SSC)
AMC Link Type (Bits 19-12)	02h (AMC.1 PCI Express)
AMC Link Designator (Bits 11-0)	F00h: AMC Channel 0,Lane0,1,2,3
AMC Link Descriptor	FE00002f00h
Reserved (Bits 39-34)	3Fh
AMC Asymmetric Match (Bits 33-32)	02h (Provides a Secondary PCI Express Port)
Link Grouping ID (Bits 31-24)	00h (Single-Channel Link)
AMC Link Type Extension (Bits 23-20)	00h (Gen1 NO SSC)
AMC Link Type (Bits 19-12)	02h (AMC.1 PCI Express)

The following table gives AMC connectivity details for "Intel IOH PCI-Express Root Complex Port 8" (On-Carrier Device 1).

Table 4-27: AMC connectivity details for "Intel IOH PCI-Express Root Complex Port 8"

Field	Value
Record Type ID	C0h
Record format version	02h
Record Length	*Calculated
Record Checksum	*Calculated
Header Checksum	*Calculated
Manufacturer ID	00315Ah
PICMG Record ID	19h (AMC Point-To-Point Connectivity Record)
Record Format Version	00h
OEM GUID Count	0h
Record Type/Connected-device ID	01h(Carrier, Device 0->Intel IOH PCI-Express Root Complex Port 8)
AMC Channel Descriptor Count	01h
AMC Channel Descriptor	F18820h
Reserved (Bits 23-20)	0Fh
Lane 3 Port Number (Bits 19-15)	03h
Lane 2 Port Number (Bits 14-10)	02h
Lane 1 Port Number (Bits 9-5)	01h
Lane 0 Port Number (Bits 4-0)	00h
AMC Link Descriptor	FE00302f01h
Reserved (Bits 39-34)	3Fh
AMC Asymmetric Match (Bits 33-32)	02h (Provides a Secondary PCI Express Port)
Link Grouping ID (Bits 31-24)	00h (Single-Channel Link)
AMC Link Type Extension (Bits 23-20)	03h (Gen2 SSC)
AMC Link Type (Bits 19-12)	02h (AMC.1 PCI Express)
AMC Link Designator (Bits 11-0)	F01h: AMC Channel 1, Lane0,1,2,3
AMC Link Descriptor	FE00202f01h
Reserved (Bits 39-34)	3Fh
AMC Asymmetric Match (Bits 33-32)	02h (Provides a Secondary PCI Express Port)
Link Grouping ID (Bits 31-24)	00h (Single-Channel Link)
AMC Link Type Extension (Bits 23-20)	02h (Gen2 NO SSC)
AMC Link Type (Bits 19-12)	02h (AMC.1 PCI Express)
AMC Link Designator (Bits 11-0)	F01h: AMC Channel 1, Lane0,1,2,3
AMC Link Descriptor	FE00102f01h
Reserved (Bits 39-34)	3Fh
AMC Asymmetric Match (Bits 33-32)	02h (Provides a Secondary PCI Express Port)
Link Grouping ID (Bits 31-24)	00h (Single-Channel Link)
AMC Link Type Extension (Bits 23-20)	01h (Gen1 SSC)
AMC Link Type (Bits 19-12)	02h (AMC.1 PCI Express)
AMC Link Designator (Bits 11-0)	F01h: AMC Channel 1, Lane0,1,2,3
AMC Link Descriptor	FE00002f01h
Reserved (Bits 39-34)	3Fh

Field	Value
AMC Asymmetric Match (Bits 33-32)	02h (Provides a Secondary PCI Express Port)
Link Grouping ID (Bits 31-24)	00h (Single-Channel Link)
AMC Link Type Extension (Bits 23-20)	00h (Gen1 NO SSC)
AMC Link Type (Bits 19-12)	02h (AMC.1 PCI Express)
AMC Link Designator (Bits 11-0)	F01h: AMC Channel 1, Lane0,1,2,3
AMC Link Descriptor	FE00302101h
Reserved (Bits 39-34)	3Fh
AMC Asymmetric Match (Bits 33-32)	02h (Provides a Secondary PCI Express Port)
Link Grouping ID (Bits 31-24)	00h (Single-Channel Link)
AMC Link Type Extension (Bits 23-20)	03h (Gen2 SSC)
AMC Link Type (Bits 19-12)	02h (AMC.1 PCI Express)
AMC Link Designator (Bits 11-0)	101h: AMC Channel 1, Lane0
AMC Link Descriptor	FE00202101h
Reserved (Bits 39-34)	3Fh
AMC Asymmetric Match (Bits 33-32)	02h (Provides a Secondary PCI Express Port)
Link Grouping ID (Bits 31-24)	00h (Single-Channel Link)
AMC Link Type Extension (Bits 23-20)	02h (Gen2 NO SSC)
AMC Link Type (Bits 19-12)	02h (AMC.1 PCI Express)
AMC Link Designator (Bits 11-0)	101h: AMC Channel 1, Lane0
AMC Link Descriptor	FE00102101h
Reserved (Bits 39-34)	3Fh
AMC Asymmetric Match (Bits 33-32)	02h (Provides a Secondary PCI Express Port)
Link Grouping ID (Bits 31-24)	00h (Single-Channel Link)
AMC Link Type Extension (Bits 23-20)	01h (Gen1 SSC)
AMC Link Type (Bits 19-12)	02h (AMC.1 PCI Express)
AMC Link Designator (Bits 11-0)	101h: AMC Channel 1, Lane0
AMC Link Descriptor	FE00002101h
Reserved (Bits 39-34)	3Fh
AMC Asymmetric Match (Bits 33-32)	02h (Provides a Secondary PCI Express Port)
Link Grouping ID (Bits 31-24)	00h (Single-Channel Link)
AMC Link Type Extension (Bits 23-20)	00h (Gen1 NO SSC)
AMC Link Type (Bits 19-12)	02h (AMC.1 PCI Express)
AMC Link Designator (Bits 11-0)	101h: AMC Channel 1, Lane0

The following table gives AMC connectivity details for "Intel ICH10 SATA Controller" (On-Carrier Device 2).

Table 4-28: AMC connectivity details for "Intel ICH10 SATA Controller"

Field	Value
Record Type ID	C0h
Record format version	02h
Record Length	*Calculated
Record Checksum	*Calculated
Header Checksum	*Calculated
Manufacturer ID	00315Ah
PICMG Record ID	19h (AMC Point-To-Point Connectivity Record)
Record Format Version	00h
OEM GUID Count	0h
Record Type/Connected-device ID	02h(Carrier,Device 2->Intel ICH10 SATA Controller)
AMC Channel Descriptor Count	02h
AMC Channel Descriptor	FFFFE0h
Reserved (Bits 23-20)	0Fh
Lane 3 Port Number (Bits 19-15)	1Fh
Lane 2 Port Number (Bits 14-10)	1Fh
Lane 1 Port Number (Bits 9-5)	1Fh
Lane 0 Port Number (Bits 4-0)	00h
AMC Channel Descriptor	FFFFE1h
Reserved (Bits 23-20)	0Fh
Lane 3 Port Number (Bits 19-15)	1Fh
Lane 2 Port Number (Bits 14-10)	1Fh
Lane 1 Port Number (Bits 9-5)	1Fh
Lane 0 Port Number (Bits 4-0)	01h
AMC Link Descriptor	FE00107102h
Reserved (Bits 39-34)	3Fh
AMC Asymmetric Match (Bits 33-32)	02h (Implements SATA Client interface)
Link Grouping ID (Bits 31-24)	00h (Single-Channel Link)
AMC Link Type Extension (Bits 23-20)	01h (Serial ATA)
AMC Link Type (Bits 19-12)	07h (AMC.3 Storage)
AMC Link Designator (Bits 11-0)	102h: AMC Channel 2, Lane0
AMC Link Descriptor	FE00107103h
Reserved (Bits 39-34)	3Fh
AMC Asymmetric Match (Bits 33-32)	02h (Implements SATA Client interface)
Link Grouping ID (Bits 31-24)	00h (Single-Channel Link)
AMC Link Type Extension (Bits 23-20)	01h (Serial ATA)
AMC Link Type (Bits 19-12)	07h (AMC.3 Storage)
AMC Link Designator (Bits 11-0)	103h: AMC Channel 3, Lane0

The following table gives AMC connectivity details for "Intel 82576EB (front/rear)" (On-Carrier Device 3).

Table 4-29:AMC connectivity details for "Intel 82576EB NC (front/rear)"

Field	Value
Record Type ID	C0h
Record format version	02h
Record Length	*Calculated
Record Checksum	*Calculated
Header Checksum	*Calculated
Manufacturer ID	00315Ah
PICMG Record ID	19h (AMC Point-To-Point Connectivity Record)
Record Format Version	00h
OEM GUID Count	0h
Record Type/Connected-device ID	03h(Carrier,Device 3->Intel 82576EB NC (front/rear))
AMC Channel Descriptor Count	02h
AMC Channel Descriptor	FFFFE0h
Reserved (Bits 23-20)	0Fh
Lane 3 Port Number (Bits 19-15)	1Fh
Lane 2 Port Number (Bits 14-10)	1Fh
Lane 1 Port Number (Bits 9-5)	1Fh
Lane 0 Port Number (Bits 4-0)	00h
AMC Channel Descriptor	FFFFE1h
Reserved (Bits 23-20)	0Fh
Lane 3 Port Number (Bits 19-15)	1Fh
Lane 2 Port Number (Bits 14-10)	1Fh
Lane 1 Port Number (Bits 9-5)	1Fh
Lane 0 Port Number (Bits 4-0)	01h
AMC Link Descriptor	FC00005104h
Reserved (Bits 39-34)	3Fh
AMC Asymmetric Match (Bits 33-32)	00h (Exact match)
Link Grouping ID (Bits 31-24)	00h (Single-Channel Link)
AMC Link Type Extension (Bits 23-20)	00h (1000 BaseBX)
AMC Link Type (Bits 19-12)	05h (AMC.2 Ethernet)
AMC Link Designator (Bits 11-0)	104h: AMC Channel 4,Lane0
AMC Link Descriptor	FC00005105h
Reserved (Bits 39-34)	3Fh
AMC Asymmetric Match (Bits 33-32)	00h (Exact match)
Link Grouping ID (Bits 31-24)	00h (Single-Channel Link)
AMC Link Type Extension (Bits 23-20)	00h (1000 BaseBX)
AMC Link Type (Bits 19-12)	05h (AMC.2 Ethernet)
AMC Link Designator (Bits 11-0)	105h: AMC Channel 5,Lane0

The following table gives AMC connectivity details for "Onboard Fabric Channel 1 Switch" (On-Carrier Device 4).

Table 4-30:AMC connectivity details for "Onboard Fabric Channel 1 Switch"

Field	Value
Record Type ID	C0h
Record format version	02h
Record Length	*Calculated
Record Checksum	*Calculated
Header Checksum	*Calculated
Manufacturer ID	00315Ah
PICMG Record ID	19h (AMC Point-To-Point Connectivity Record)
Record Format Version	00h
OEM GUID Count	0h
Record Type/Connected-device ID	04h(Carrier,Device 4->Onboard Fabric Channel 1 Switch)
AMC Channel Descriptor Count	02h
AMC Channel Descriptor	FFF7E7h
Reserved (Bits 23-20)	0Fh
Lane 3 Port Number (Bits 19-15)	1Fh
Lane 2 Port Number (Bits 14-10)	1Fh
Lane 1 Port Number (Bits 9-5)	1Fh
Lane 0 Port Number (Bits 4-0)	007h
AMC Channel Descriptor	FFF7E8h
Reserved (Bits 23-20)	0Fh
Lane 3 Port Number (Bits 19-15)	1Fh
Lane 2 Port Number (Bits 14-10)	1Fh
Lane 1 Port Number (Bits 9-5)	1Fh
Lane 0 Port Number (Bits 4-0)	08h
AMC Link Descriptor	FC00005106h
Reserved (Bits 39-34)	3Fh
AMC Asymmetric Match (Bits 33-32)	00h (Exact match)
Link Grouping ID (Bits 31-24)	00h (Single-Channel Link)
AMC Link Type Extension (Bits 23-20)	00h (1000 BaseBX)
AMC Link Type (Bits 19-12)	05h (AMC.2 Ethernet)
AMC Link Designator (Bits 11-0)	106h: AMC Channel 6,Lane0
AMC Link Descriptor	FC00005107h
Reserved (Bits 39-34)	3Fh
AMC Asymmetric Match (Bits 33-32)	00h (Exact match)
Link Grouping ID (Bits 31-24)	00h (Single-Channel Link)
AMC Link Type Extension (Bits 23-20)	00h (1000 BaseBX)
AMC Link Type (Bits 19-12)	05h (AMC.2 Ethernet)
AMC Link Designator (Bits 11-0)	107h: AMC Channel 7,Lane0

The following table gives AMC connectivity details for "Onboard Fabric Channel 2 Switch" (On-Carrier Device 5).

Table 4-31:AMC connectivity details for "Onboard Fabric Channel 2 Switch"

Field	Value
Record Type ID	C0h
Record format version	02h
Record Length	*Calculated
Record Checksum	*Calculated
Header Checksum	*Calculated
Manufacturer ID	00315Ah
PICMG Record ID	19h (AMC Point-To-Point Connectivity Record)
Record Format Version	00h
OEM GUID Count	0h
Record Type/Connected-device ID	05h(Carrier,Device 5->Onboard Fabric Channel 2 Switch)
AMC Channel Descriptor Count	02h
AMC Channel Descriptor	FFFFE7h
Reserved (Bits 23-20)	0Fh
Lane 3 Port Number (Bits 19-15)	1Fh
Lane 2 Port Number (Bits 14-10)	1Fh
Lane 1 Port Number (Bits 9-5)	1Fh
Lane 0 Port Number (Bits 4-0)	07h
AMC Channel Descriptor	FFFFE8h
Reserved (Bits 23-20)	0Fh
Lane 3 Port Number (Bits 19-15)	1Fh
Lane 2 Port Number (Bits 14-10)	1Fh
Lane 1 Port Number (Bits 9-5)	1Fh
Lane 0 Port Number (Bits 4-0)	08h
AMC Link Descriptor	FC00005108h
Reserved (Bits 39-34)	3Fh
AMC Asymmetric Match (Bits 33-32)	00h (Exact match)
Link Grouping ID (Bits 31-24)	00h (Single-Channel Link)
AMC Link Type Extension (Bits 23-20)	00h (1000 BaseBX)
AMC Link Type (Bits 19-12)	05h (AMC.2 Ethernet)
AMC Link Designator (Bits 11-0)	108h: AMC Channel 8, Lane0
AMC Link Descriptor	FC00005109h
Reserved (Bits 39-34)	3Fh
AMC Asymmetric Match (Bits 33-32)	00h (Exact match)

Field	Value
Link Grouping ID (Bits 31-24)	00h (Single-Channel Link)
AMC Link Type Extension (Bits 23-20)	00h (1000 BaseBX)
AMC Link Type (Bits 19-12)	05h (AMC.2 Ethernet)
AMC Link Designator (Bits 11-0)	109h: AMC Channel 9, Lane0

The following table gives AMC connectivity details for COM2 (On-Carrier Device 5)

Table 4-32:AMC connectivity details for "FPGA Based UART"

Field	Value
Record Type ID	C0h
Record format version	02h
Record Length	*Calculated
Record Checksum	*Calculated
Header Checksum	*Calculated
Manufacturer ID	00315Ah
PICMG Record ID	19h (AMC Point-To-Point Connectivity Record)
Record Format Version	00h
OEM GUID Count	1h
OEM GUID Id 0	471C5D14-2AE7-42B9-A9B0-0628546B42CC (OEM Module Serial Console Interconnect)
Record Type/Connected-device ID	06h(Carrier,Device 6->FPGA Based UART)
AMC Channel Descriptor Count	01h
AMC Channel Descriptor	FFFEE0h
Reserved (Bits 23-20)	0Fh
Lane 3 Port Number (Bits 19-15)	1Fh
Lane 2 Port Number (Bits 14-10)	1Fh
Lane 1 Port Number (Bits 9-5)	1Fh
Lane 0 Port Number (Bits 4-0)	00h
AMC Link Descriptor	FC000f010ah
Reserved (Bits 39-34)	3Fh
AMC Asymmetric Match (Bits 33-32)	00h (Exact match)
Link Grouping ID (Bits 31-24)	00h (Single-Channel Link)
AMC Link Type Extension (Bits 23-20)	00h (None)
AMC Link Type (Bits 19-12)	F0h (OEM Module Serial Console Interconnect)
AMC Link Designator (Bits 11-0)	10Ah: AMC Channel 10, Lane0

The AMC connectivity details for "On-Carrier Virtual RTM Device" is embedded on the RTM itself.

4.3.4 Clock E-Keying Information

The clock ekeying is used to find and activate matching clock pairs to/from available clock sources and clock receivers.

The board has a clock generator used as the (PCIe) FCLKA of AMC B1. Additionally, clocks from/to the ATCA backplane can be driven to/from the AMC B1 site using an on-carrier clock multiplexer.

The following table gives the clock resources id assignment mapping.

Table 4-33:Clock resources id assignment mapping

OnBoard Clock Device	Clock Resource Id
PCIe Clock Generator	0
Clock Multiplexer	1

4.3.4.1 Clock Point-To-Point Connectivity Information

The following table gives all the clock link paths available on the Front Board Unit, as they appear in the FRU data in the Carrier Clock Point-to-Point Connectivity Record Table record.

Table 4-34:Carrier Clock Point-to-Point Connectivity Record Table

Field	Value	Description
Record Type ID	C0h	
Record format version	02h	
Record Length	*Calculated	
Record Checksum	*Calculated	
Header Checksum	*Calculated	
Manufacturer ID	00315Ah	PICMG Record ID
PICMG Record ID	2Ch	Carrier Clock Point-To-Point Connectivity Record
Record Format Version	00h	
Clock Point-To-Point Resource Descriptor Count (m)	0x02	
Clock Point-To-Point Resource Descriptor		
Clock Resource Id	0x00	7:6 00b = On-Carrier device 5:4 0h (reserved) 3:0 On-Carrier Device 0 (PCIe clock generator)
Clock Point-to-Point Connection Count	0x01	
Point-to-Point Clock Connection descriptor		
Local Clock Id	0x00	On-Carrier Clock Id 0
Remote Clock Id	0x05	AMC.0 R2.0 FCLKA clock
Remote Clock Resource Id	0x45	7:6 01b = AMC 5:4 0h (reserved) 3:0 AMC Site Number (5 = AMC B1)
Clock Point-To-Point Resource Descriptor		

Field	Value	Description
Clock Resource Id	0x01	7:6 00b = On-Carrier device 5:4 0h (reserved) 3:0 On-Carrier Device 1(Clock Mux)
Clock Point-to-Point Connection Count	0x0A	
Point-to-Point Clock Connection descriptor		
Local Clock Id	0x00	On-Carrier Clock Id 0
Remote Clock Id	0x01	CLK1A
Remote Clock Resource Id	0x80	7:6 10b = Backplane clock 5:4 0h (reserved) 3:0 0h
Point-to-Point Clock Connection descriptor		
Local Clock Id	0x01	On-Carrier Clock Id 1
Remote Clock Id	0x02	CLK1B
Remote Clock Resource Id	0x80	7:6 10b = Backplane clock 5:4 0h (reserved) 3:0 0h
Point-to-Point Clock Connection descriptor		
Local Clock Id	0x02	On-Carrier Clock Id 2
Remote Clock Id	0x04	CLK2A
Remote Clock Resource Id	0x80	7:6 10b = Backplane clock 5:4 0h (reserved) 3:0 0h
Point-to-Point Clock Connection descriptor		
Local Clock Id	0x03	On-Carrier Clock Id 3
Remote Clock Id	0x05	CLK2B
Remote Clock Resource Id	0x80	7:6 10b = Backplane clock 5:4 0h (reserved) 3:0 0h
Point-to-Point Clock Connection descriptor		
Local Clock Id	0x04	On-Carrier Clock Id 4
Remote Clock Id	0x07	CLK3A
Remote Clock Resource Id	0x80	7:6 10b = Backplane clock 5:4 0h (reserved) 3:0 0h
Point-to-Point Clock Connection descriptor		
Local Clock Id	0x05	On-Carrier Clock Id 5
Remote Clock Id	0x08	CLK3B
Remote Clock Resource Id	0x80	7:6 10b = Backplane clock 5:4 0h (reserved) 3:0 0h
Point-to-Point Clock Connection descriptor		
Local Clock Id	0x06	On-Carrier Clock Id 6
Remote Clock Id	0x01	TCLKA
Remote Clock Resource Id	0x45	7:6 01b = AMC 5:4 0h (reserved) 3:0 AMC Site Number (5 = AMC B1)
Point-to-Point Clock Connection descriptor		

Field	Value	Description
Local Clock Id	0x07	On-Carrier Clock Id 7
Remote Clock Id	0x03	TCLKC
Remote Clock Resource Id	0x45	7:6 01b = AMC 5:4 0h (reserved) 3:0 AMC Site Number (5 = AMC B1)
Point-to-Point Clock Connection descriptor		
Local Clock Id	0x08	On-Carrier Clock Id 8
Remote Clock Id	0x04	TCLKB
Remote Clock Resource Id	0x45	7:6 01b = AMC 5:4 0h (reserved) 3:0 AMC Site Number (5 = AMC B1)
Point-to-Point Clock Connection descriptor		
Local Clock Id	0x09	On-Carrier Clock Id 9
Remote Clock Id	0x04	TCLKD
Remote Clock Resource Id	0x45	7:6 01b = AMC 5:4 0h (reserved) 3:0 AMC Site Number (5 = AMC B1)

4.3.4.2 Clock Configuration Information

The following table gives AMC clock connectivity details for "PCIe Clock Generator" (On-Carrier Device 0).

Table 4-35:PCIe Clock Generator

Field	Value	Description
Record Type ID	C0h	
Record format version	02h	
Record Length	*Calculated	
Record Checksum	*Calculated	
Header Checksum	*Calculated	
Manufacturer ID	00315Ah	PICMG Record ID
PICMG Record ID	2Dh	Clock Configuration Record
Record Format Version	00h	
Clock Resource Id	0x00	7:6 00b = On-Carrier device 5:4 0h (reserved) 3:0 00h = On-Carrier Device 0 (PCIe clock generator)
Clock Configuration Descriptor Count	0x01	
Clock Configuration Descriptors		
Clock Id	0x00	
Clock Control	0x00	7:1 0h (reserved) [0] 0b = Activated by Carrier IPMC
Indirect Clock Descriptors Count(m)	0x00	
Direct Clock Descriptors Count(n)	0x01	
Indirect clock Descriptor		None
Direct clock Descriptor		
Features	0x01	7:2 0h (reserved) [1] 0b = Not connected through PLL [0] 1b = Clock source

Field	Value	Description
Family	0x02	Reserved for PCI Express
Accuracy Level	0x0E	Gen 2 Capable PCIe Clock
Frequency	0x05F5E100	As defined in AMC.1 R2.0
Min Clock	0x05F5E100	As defined in AMC.1 R2.0
Max Clock	0x05F5E100	As defined in AMC.1 R2.0

The following table gives AMC clock connectivity details for "Onboard Clock Multiplexer" (On-Carrier Device 1).

Table 4-36: Onboard Clock Multiplexer

Field	Value	Description
Record Type ID	C0h	
Record format version	02h	
Record Length	*Calculated	
Record Checksum	*Calculated	
Header Checksum	*Calculated	
Manufacturer ID	00315Ah	PICMG Record ID
PICMG Record ID	2D	Clock Configuration Record
Record Format Version	00h	
Clock Resource Id	0x01	7:6 00b = On-Carrier device 5:4 0h (reserved) 3:0 01h = On-Carrier Device 1 (Clock Multiplexer)
Clock Configuration Descriptor Count	0x0A	
Clock Configuration Descriptors		
Clock Id	0x00	Receiver input from CLK1A
Clock Control	0x01	7:1 0h (reserved) [0] 1b = Activated by Application
Indirect Clock Descriptors Count(m)	0x02	
Direct Clock Descriptors Count(n)	0x00	
Indirect clock Descriptor		
Features	0x02	7:2 0h (reserved) [1] 1b = Connected through PLL [0] 0b = Clock Receiver
Dependent ClockId	6	
Features	0x02	7:2 0h (reserved) [1] 1b = Connected through PLL [0] 0b = Clock Receiver
Dependent ClockId	7	
Direct clock Descriptor		none
Clock Id	0x01	Receiver input from CLK1B
Clock Control	0x01	7:1 0h (reserved) [0] 1b = Activated by Application
Indirect Clock Descriptors Count(m)	0x02	
Direct Clock Descriptors Count(n)	0x00	
Indirect clock Descriptor		
Features	0x02	7:2 0h (reserved) [1] 1b = Connected through PLL [0] 0b = Clock Receiver

Field	Value	Description
Dependent ClockId	6	
Features	0x02	7:2 0h (reserved) [1] 1b = Connected through PLL [0] 0b = Clock Receiver
Dependent ClockId	7	
Direct clock Descriptor		none
Clock Id	0x02	Receiver input from CLK2A
Clock Control	0x01	7:1 0h (reserved) [0] 1b = Activated by Application
Indirect Clock Descriptors Count(m)	0x02	
Direct Clock Descriptors Count(n)	0x00	
Indirect clock Descriptor		
Features	0x02	7:2 0h (reserved) [1] 1b = Connected through PLL [0] 0b = Clock Receiver
Dependent ClockId	6	
Features	0x02	7:2 0h (reserved) [1] 1b = Connected through PLL [0] 0b = Clock Receiver
Dependent ClockId	7	
Direct clock Descriptor		none
Clock Id	0x03	Receiver input from CLK2B
Clock Control	0x01	7:1 0h (reserved) [0] 1b = Activated by Application
Indirect Clock Descriptors Count(m)	0x02	
Direct Clock Descriptors Count(n)	0x00	
Indirect clock Descriptor		
Features	0x02	7:2 0h (reserved) [1] 1b = Connected through PLL [0] 0b = Clock Receiver
Dependent ClockId	6	
Features		7:2 0h (reserved) [1] 1b = Connected through PLL [0] 0b = Clock Receiver
Dependent ClockId	7	
Direct clock Descriptor		none
Clock Id	0x04	Source output to CLK3A
Clock Control	0x01	7:1 0h (reserved) [0] 1b = Activated by Application
Indirect Clock Descriptors Count(m)	0x02	
Direct Clock Descriptors Count(n)	0x00	
Indirect clock Descriptor		
Features	0x01	7:2 0h (reserved) [1] 0b = Not Connected through PLL [0] 1b = Clock Source
Dependent ClockId	8	
Features	0x01	7:2 0h (reserved) [1] 0b = Not Connected through PLL [0] 1b = Clock Source
Dependent ClockId	9	
Direct clock Descriptor		none
Clock Id	0x05	Source output to CLK3B
Clock Control	0x01	7:1 0h (reserved) [0] 1b = Activated by Application
Indirect Clock Descriptors Count(m)	0x02	

Field	Value	Description
Direct Clock Descriptors Count(n)	0x00	
Indirect clock Descriptor		
Features	0x01	7:2 0h (reserved) [1] 0b = Not Connected through PLL [0] 1b = Clock Source
Dependent ClockId	8	
Features	0x01	7:2 0h (reserved) [1] 0b = Not Connected through PLL [0] 1b = Clock Source
Dependent ClockId	9	
Direct clock Descriptor		none
Clock Id	0x06	Source output to TCLKA
Clock Control	0x01	7:1 0h (reserved) [0] 1b = Activated by Application
Indirect Clock Descriptors Count(m)	0x04	
Direct Clock Descriptors Count(n)	0x00	
Indirect clock Descriptor		
Features	0x03	7:2 0h (reserved) [1] 1b = Connected through PLL [0] 1b = Clock Source
Dependent ClockId	0	
Features	0x03	7:2 0h (reserved) [1] 1b = Connected through PLL [0] 1b = Clock Source
Dependent ClockId	1	
Features	0x03	7:2 0h (reserved) [1] 1b = Connected through PLL [0] 1b = Clock Source
Dependent ClockId	2	
Features	0x03	7:2 0h (reserved) [1] 1b = Connected through PLL [0] 1b = Clock Source
Dependent ClockId	3	
Direct clock Descriptor		none
Clock Id	0x07	Source output to TCLKC
Clock Control	0x01	7:1 0h (reserved) [0] 1b = Activated by Application
Indirect Clock Descriptors Count(m)	0x04	
Direct Clock Descriptors Count(n)	0x00	
Indirect clock Descriptor		
Features	0x03	7:2 0h (reserved) [1] 1b = Connected through PLL [0] 1b = Clock Source
Dependent ClockId	0	
Features	0x03	7:2 0h (reserved) [1] 1b = Connected through PLL [0] 1b = Clock Source
Dependent ClockId	1	
Features	0x03	7:2 0h (reserved) [1] 1b = Connected through PLL [0] 1b = Clock Source
Dependent ClockId	2	
Features	0x03	7:2 0h (reserved) [1] 1b = Connected through PLL [0] 1b = Clock Source
Dependent ClockId	3	
Direct clock Descriptor		none

Field	Value	Description
Clock Id	0x08	Receiver input from TCLKB
Clock Control	0x01	7:1 0h (reserved) [0] 1b = Activated by Application
Indirect Clock Descriptors Count(m)	0x02	
Direct Clock Descriptors Count(n)	0x00	
Indirect clock Descriptor		
Features	0x02	7:2 0h (reserved) [1] 1b = Connected through PLL [0] 0b = Clock Receiver
Dependent ClockId	4	4
Features	0x02	7:2 0h (reserved) [1] 1b = Connected through PLL [0] 0b = Clock Receiver
Dependent ClockId	5	
Direct clock Descriptor		none
Clock Id	0x09	Receiver input from TCLKD
Clock Control	0x01	7:1 0h (reserved) [0] 1b = Activated by Application
Indirect Clock Descriptors Count(m)	0x02	
Direct Clock Descriptors Count(n)	0x00	
Indirect clock Descriptor		
Features	0x02	7:2 0h (reserved) [1] 1b = Connected through PLL [0] 0b = Clock Receiver
Dependent ClockId	4	
Features	0x02	7:2 0h (reserved) [1] 1b = Connected through PLL [0] 0b = Clock Receiver
Dependent ClockId	5	
Direct clock Descriptor		none

4.3.5 Component Upgrade Support

Many components can be updated through the IPMC. Most of them (IPMC itself, FPGA and BIOS) are updated using the HPM.1 Hardware Platform Management IPM Controller Firmware Upgrade Specification revision 1.0. Kontron's IPMC firmware already complies to PICMG HPM.1 R1.0. HPM commands are available from any of the MC messaging interfaces. The images of the different components can be packaged in the same HPM image (They can also be separated). Packaging the images together allows to upgrade all the components using only one upgrade instruction. Moreover, it ensure all components upgraded are compatible.

The following table gives the HPM component IDs implemented on the AT8050.

Table 4-37:HPM component IDs

Component ID	Description
0	MC Bootblock
1	IPMC Firmware
2	FPGA
3	BIOS

Furthermore, non-HPM components can also be updated via the MC.

Table 4-38:non-HPM components

Non HPM Component	Description
CMOS	CMOS information, programmed through Master Write/Read API
FRU Data	The FRU inventory information is updated via "Write FRU Data" commands
ME	Management Engine, updated through Intel's OEM update commands

Chapter 5

Software Setup

5.1	AMI BIOS Setup Program.....	84
5.2	Boot Utilities.....	113
5.3	Console Redirection (VT100 Mode).....	114

5. Software Setup

5.1 AMI BIOS Setup Program

All relevant information for operating the board and connected peripherals is stored in the CMOS memory backed-up by a supercap or in the main BIOS flash and EEPROM. The latest is the default configuration.

5.1.1 Accessing the BIOS Setup Utility

The system BIOS (Basic Input Output System) provides an interface between the operating system and the hardware of the AT8050. It uses the AMI Setup program, a setup utility in flash memory that is accessed by pressing the (or <F4> from a console redirection terminal) key at the appropriate time during system boot. This utility is used to set configuration data in CMOS RAM.

To run the AMI Setup program incorporated in the ROM BIOS:

- Turn on or reboot the system.
- When you get the following messages, hit key to enter SETUP.

```
AMIBIOS(C)2010 American Megatrends, Inc.
KONTRON AT8050 BIOS Version 3.00
```

```
(C) American Megatrends, Inc.
64-3047-009999-00101111-031710-TYLSBURG-5007_300-Y2KC
```

```
Physical Processors Package: 1
Active Processors Cores: 4
Logical Processors: 8
Intel HT Technology: Enabled
QPI Speed: 5.866GT
CPU : Intel(R) Xeon(R) CPU L5518 @ 2.13GHz
Speed : 2.13 GHz
```

```
Reset Type: Cold Reset
Currently Running On Primary BIOS.
```

```
Press DEL to run Setup (F4 on Remote Keyboard)
Press F12 if you want to boot from the network
Press F11 for BBS POPUP (F3 on Remote Keyboard)
Initializing USB Controllers .. Done.
```

```
Memory Channel 0 DIMM 0 Size 2048MB
Memory Channel 0 DIMM 1 Size Not Installed
Memory Channel 1 DIMM 0 Size 2048MB
Memory Channel 1 DIMM 1 Size Not Installed
Memory Channel 2 DIMM 0 Size 2048MB
Memory Channel 2 DIMM 1 Size Not Installed
DDR3: 6144MB OK, Speed: 1066MHz
```

```
Auto-detecting USB Mass Storage Devices ..
00 USB mass storage devices found and configured.
```

The main menu of the AMI BIOS CMOS Setup Utility appears on the screen.

```

Main      Advanced      Security      Boot      System Management      Exit
*****
* System Overview                                     * Sub-menu to display *
* *****                                           * memory configuration *
* AMIBIOS                                           * of each DIMM       *
* BIOS Version          08.00.15                    *                   *
* Build Date:          03/24/10                       *                   *
* BIOS ID              5007_300                       *                   *
* FPGA Version:       2.04                            *                   *
*                   *                               *                   *
* System Memory       1016MB                          *                   *
* System Memory Speed 1333MHz                         *                   *
* * Memory Size Configuration                       *                   *
*                   *                               *                   *
*                   * *      Select Screen          *                   *
*                   * **      Select Item           *                   *
*                   * Enter  Go to Sub Screen      *                   *
*                   * F1       General Help         *                   *
* System Time         [23:33:11]                     * F10      Save and Exit *
* System Time         [23:33:14]                     * F10      Save and Exit *
*                   *                               *                   *
*                   *                               *                   *
*****
v02.61 (C)Copyright 1985-2010, American Megatrends, Inc.

```

Setup Default values provide optimum performance settings for all devices and system features.



Note:

The CMOS setup option described in this section is based on BIOS Version 3.00. The options and default settings may change in a new BIOS release.



CAUTION

These parameters have been provided to give control over the system. However, the values for these options should be changed only if the user has a full understanding of the timing relationships involved.



Note:

All options in Bold are the default settings.



WARNING

BIOS V3.00 and higher is required to operate the board with a 5600 series processor.



5.1.2 Menu Bar

The Menu Bar at the top of the window lists these selections:

Menu Selection	Description
Main	Use this menu for basic system configuration.
Advanced	Use this menu to set the Advanced Features available on your system.
Security	Use this menu to configure Security features.
Boot	Use this menu to determine the booting device order.
System Management	Use this menu to set and view the System Management on your system.
Exit	Use this menu to choose Exits option.

Use the left and right arrows keys to make a selection.

5.1.2.1 Legend Bar

Use the keys listed in the legend bar on the bottom to make your selections or exit the current menu. The chart on the following page describes the legend keys and their alternates.

Key	Function
<F1>	General Help windows.
<Esc>	Exit this menu.
--> arrow keys	Select a different menu.
<Home> or <End>	Move cursor to top or bottom of window.
<PgUp> or <PgDn>	Move cursor to top or bottom of window.
<->	Select the Previous Value for the field.
<+>	Select the Next Value for the field.
<F2> and <F3>	Change colors used in Setup.
<F7>	Disacard the changes for all menus.
<F9>	Load the Optimal Default Configuration values for all menus.
<F10>	Save and exit.
<Enter>	Execute Command, display possible value for this field or Select the sub-menu.

To select an item, use the arrow keys to move the cursor to the field you want. Then use the plus-and-minus value keys to select a value for that field. To save value commands in the Exit Menu, save the values displayed in all menus.

To display a submenu, use the arrow keys to move the cursor to the submenu you want. Then press <Enter>.

5.1.2.2 Field Help Window

The help window on the right side of each menu displays the help text for the selected field.

It updates as you move the cursor to each field.

5.1.2.3 General Help Windows

Pressing <F1> on any menu brings up the General Help window that describes the legend keys and their alternates:

General Help	
←→	Select Screen
+ -	Change Option/Field
PGDN	Next Page
HOME	Go to Top of Screen
F2/F3	Change Colors
F9	Load Defaults
F10	Save and Exit
↑↓	Select Item
Enter	Go to Sub Screen
PGUP	Previous Page
END	Go to Bottom of Screen
F7	Discard Changes
ESC	Exit
[OK]	

5.1.3 Main Menu

Feature	Option	Description	Help text
BIOS Version	8.00.15	Displays the AMI BIOS version.	N/A, display only.
Build Date	MM/DD/YY	Display the BIOS build Date.	N/A, display only.
BIOS ID	5007_XYY	Display the BIOS ID, this include the BIOS Version.	N/A, display only.
FPGA Version	X.YY	Display the FPGA Version.	N/A, display only.
System Memory	X KB	Displays amount system memory.	N/A, display only.
System Memory Speed	X KB	Displays speed of the system memory.	N/A, display only.
Memory Size Configuration	N/A	Select sub-menu.	Sub-menu to display memory configuration of each DIMM.
System Time	HH:MM:SS	Set the system time.	Use [+] or [-] to configure system time.
System Date	MM/DD/YYYY	Set the system date.	Use [+] or [-] to configure system date.

5.1.3.1 Memory Size Configuration menu

Feature	Option	Description	Help text
Channel 0, DIMM 0 Memory Size	X GB	Displays Channel 0, DIMM 0 memory size. AT8050: DIMM electrically farthest to CPU (filled first). DIMMs within a channel must be populated starting with the DIMMs farthest from the processor in a "fill-farthest" approach.	N/A, display only.
Channel 0, DIMM 1 Memory Size	X GB	Displays Channel 0, DIMM 1 memory size. AT8050: DIMM electrically closest to CPU (filled last).	N/A, display only.
Channel 1, DIMM 0 Memory Size	X GB	Displays Channel 1, DIMM 0 memory size. AT8050: DIMM electrically farthest to CPU (filled first). DIMMs within a channel must be populated starting with the DIMMs farthest from the processor in a "fill-farthest" approach.	N/A, display only.
Channel 1, DIMM 1 Memory Size	X GB	Displays Channel 1, DIMM 1 memory size. AT8050: DIMM electrically closest to CPU (filled last).	N/A, display only.
Channel 2, DIMM 0 Memory Size	X GB	Displays Channel 2, DIMM 0 memory size. AT8050: DIMM electrically farthest to CPU (filled first). DIMMs within a channel must be populated starting with the DIMMs farthest from the processor in a "fill-farthest" approach.	N/A, display only.
Channel 2, DIMM 1 Memory Size	X GB	Displays Channel 2, DIMM 1 memory size. AT8050: DIMM electrically closest to CPU (filled last).	N/A, display only.
System Memory Speed	X MHz	Displays system Memory speed	N/A, display only.

5.1.4 Advanced Menu

Feature	Option	Description	Help text
Advanced Processor Configuration	N/A	Selects sub-menu.	N/A
ACPI Configuration	N/A	Selects sub-menu.	N/A
Drive Configuration	N/A	Selects sub-menu.	N/A
Event Log Configuration	N/A	Selects sub-menu.	N/A
Expansion ROM Configuration	N/A	Selects sub-menu.	N/A
PCI Express Configuration	N/A	Selects sub-menu.	N/A
USB Configuration	N/A	Selects sub-menu.	N/A
Advanced Chipset Control	N/A	Selects sub-menu.	N/A
Intel VT-d Configuration	N/A	Selects sub-menu.	N/A
I/O Virtualization	N/A	Selects sub-menu.	N/A

5.1.4.1 Advanced Processor Configuration sub-menu

Feature	Option	Description	Help text
Manufacturer	Display	Show information about the CPU	N/A
Frequency	Display	Show frequency of the CPU	N/A
Cache L1	Display	Show amount of L1 cache	N/A
Cache L2	Display	Show amount of L2 cache	N/A
Cache L3	Display	Show amount of L3 cache	N/A
Logical Processor	Display	Show total of processor including HT.	N/A
Physical Processor	Display	Show physical processor present in CPU	N/A
MPS and ACPI MADT ordering	Modern ordering Legacy ordering		MPS and ACPI MADT ordering. Modern ordering for Windows XP or later OSes. Legacy ordering for Windows 2000 or earlier OSes.
Max CPUID Value Limit	Disabled Enabled		Enable for legacy operating systems does not support CPUID function > 3.
Processor Virtualization	Enabled Disabled	Allow virtualization to be enable, need supported OS	Enabled: Processor virtualization in use. Disabled: Processor virtualization not in use.
CPU TM function	Enabled Disabled	The Core i7 support only all enabled or all disabled.	CPU Thermal Monitor mechanism supported TM1 and TM2. They are all enabled together.
Intel® HT Technology	Enabled Disabled	This allows multiprocessor to be enabled.	When 'Disabled' only one thread per enabled core is enabled.
Intel® SpeedStep™ tech	Enabled Disabled	This allows Geyserville 3 to be enabled.	Disable: Disable GV3 Enable: Enable GV3
Intel® TurboMode™ tech	Enabled Disabled	This allows processor to increase speed when CPU are not used.	Turbo Mode allows processor cores to run faster than marked frequency in specific condition.

5.1.4.2 ACPI Configuration sub-menu

Feature	Option	Description	Help text
ACPI Version Features	V3.0 V2.0 V1.0	Support for 64-bit addressing for ACPI System Description Tables in ACPI 3.0, Only 32 bit for others description tables.	Enable RSDP pointers to 64-bit Fixed System Description Tables. Different ACPI version has some addition.
ACPI APIC Support	Enabled Disabled	Support for ACPI APIC table pointer to Root System Description Table, RSDT pointer list can be enabled/disabled.	Enabled: ACPI APIC table support. Disabled: ACPI APIC table not supported.
Headless Mode	Enabled Disabled	Headless operation mode through ACPI can be enabled/disabled.	Enabled: Headless operation mode through ACPI supported. Disabled: Headless operation mode through ACPI not supported.

5.1.4.3 Drive Configuration sub-menu

Feature	Option	Description	Help text
SATA#1 Configuration	Disabled Compatible Enhanced	Select whether the controller is using only legacy resources i.e. IRQ 14-15(compatible) or with memory resources only (Enhanced). Only shows when SATA#1 is configure in IDE mode.	AHCI: allows advanced SATA features such as Native Command Queuing and hot plug. IDE is legacy disk usage.
Configure SATA#1 as	AHCI IDE	Advanced Host Controller Interface (AHCI) is an	AHCI: allows advanced SATA features such as Native Command Queuing and hot plug. IDE is legacy disk usage.
SATA Port 0 (PM)	N/A	Selects sub-menu. Only shows if "Configure SATA#1 as" is set to "IDE"	While entering setup, BIOS auto detects the presence of IDE devices. This displays the status of auto detection of IDE devices.
SATA Port 1 (SM)	N/A	Selects sub-menu. Only shows if "Configure SATA#1 as" is set to "IDE"	While entering setup, BIOS auto detects the presence of IDE devices. This displays the status of auto detection of IDE devices.
SATA Port 2 (PS)	N/A	Selects sub-menu. Only shows if "Configure SATA#1 as" is set to "IDE"	While entering setup, BIOS auto detects the presence of IDE devices. This displays the status of auto detection of IDE devices.
AHCI Configuration	N/A	Selects sub-menu.	Section for AHCI Configuration.

5.1.4.3.1 SATA Port 0 (PM) Configuration sub-menu

Feature	Option	Description	Help text
Device	N/A	Display the device type (Hard disk).	Display only
Vendor	N/A	Display the vendor string of the disk.	Display only
Size	N/A	Display the size of the disk.	Display only
Ultra DMA	N/A	Display the current speed of the drive.	Display only
S.M.A.R.T.	N/A	Display the status of the Self-Monitoring, Analysis, and Reporting Technology.	Display only
Type	Auto Not Installed	Auto will detect the device. Not installed will not detect the device.	Select the type of device connected to the system.

5.1.4.3.2 SATA Port 1 (SM) Configuration sub-menu

Feature	Option	Description	Help text
Device	N/A	Display the device type (Hard disk).	Display only
Vendor	N/A	Display the vendor string of the disk.	Display only
Size	N/A	Display the size of the disk.	Display only
Ultra DMA	N/A	Display the current speed of the drive.	Display only
S.M.A.R.T.	N/A	Display the status of the Self-Monitoring, Analysis, and Reporting Technology.	Display only
Type	Auto Not Installed	Auto will detect the device. Not installed will not detect the device.	Select the type of device connected to the system.

5.1.4.3.3 SATA Port 2 (PS) configuration sub-menu fields.

Feature	Option	Description	Help text
Device	N/A	Display the device type (Hard disk).	Display only
Vendor	N/A	Display the vendor string of the disk.	Display only
Size	N/A	Display the size of the disk.	Display only
Ultra DMA	N/A	Display the current speed of the drive.	Display only
S.M.A.R.T.	N/A	Display the status of the Self-Monitoring, Analysis, and Reporting Technology.	Display only
Type	Auto Not Installed	Auto will detect the device. Not installed will not detect the device.	Select the type of device connected to the system.

5.1.4.3.4 AHCI Configuration sub-menu

Feature	Option	Description	Help text
AHCI Port0	N/A	Selects sub-menu.	While entering setup, BIOS auto detects the presence of IDE devices. This displays the status of auto detection of IDE devices.
AHCI Port1	N/A	Selects sub-menu.	While entering setup, BIOS auto detects the presence of IDE devices. This displays the status of auto detection of IDE devices.
AHCI Port2	N/A	Selects sub-menu.	While entering setup, BIOS auto detects the presence of IDE devices. This displays the status of auto detection of IDE devices.

5.1.4.3.4.1AHCI Port0 Configuration sub-menu

Feature	Option	Description	Help text
Device:	N/A	Show device type	N/A
Vendor:	N/A	Show HDD name and brand	N/A
Size	N/A	Show HDD size	N/A
SATA Port0	Auto Not Installed	When using "Not Installed" the controller will disable the device.	Select the type of device connected to the system.

5.1.4.3.4.2AHCI Port1 Configuration sub-menu

Feature	Option	Description	Help text
Device:	N/A	Show device type	N/A
Vendor:	N/A	Show HDD name and brand	N/A
Size	N/A	Show HDD size	N/A
SATA Port1	Auto Not Installed	When using "Not Installed" the controller will disable the device.	Select the type of device connected to the system.

5.1.4.3.4.3AHCI Port2 Configuration sub-menu

Feature	Option	Description	Help text
Device:	N/A	Show device type	N/A
Vendor:	N/A	Show HDD name and brand	N/A
Size	N/A	Show HDD size	N/A
SATA Port2	Auto Not Installed	When using "Not Installed" the controller will disable the device.	Select the type of device connected to the system.

5.1.4.4 Event Log Configuration sub-menu

Feature	Option	Description	Help text
View Event Log	Enter	View all unread events in the Event Log.	View all unread events in the Event Log.
Mark Events as read	Enter	Mark all unread events as read in the Event Log.	Mark all unread events as read in the Event Log.
Clear all Event Logs	Enter	Discard all events in the Event Log.	Discard all events in the Event Log.
PCIe Error Log	Yes No		Options No Yes
DRAM Data Integrity Mode	ECC Non-ECC		ECC: ECC Checking enables. Non-ECC: Use only for testing purposes.
ECC Error Reporting	Disabled Correctable Uncorrectable both		Correctable: ECC for testing purposes. Uncorrectable: ECC errors reported. Both: ECC errors for testing purposes. Disabled: ECC errors not reported.

5.1.4.5 Expansion ROM Configuration sub-menu

Feature	Option	Description	Help text
Ethernet BI Expansion ROM	Disabled iSCSI PXE	The base interface PXE Expansion ROM can be enabled/disabled. If disabled, remote LAN boot via base interface is not available to boot the system.	Disabled: Base interface PXE expansion ROM not used. If disabled, remote LAN boot via BI is not available to boot the system! iSCSI: Initializes iSCSI expansion ROM. PXE: Initializes base interface PXE expansion ROM.
Ethernet FI Expansion ROM	Disabled iSCSI PXE	The fabric interface PXE Expansion ROM can be enabled/disabled. If disabled, remote LAN boot via fabric interface is not available to boot the system.	Disabled: Fabric interface PXE expansion ROM not used. If disabled, remote LAN boot via FI is not available to boot the system! iSCSI: Initializes iSCSI expansion ROM. PXE: Initializes fabric interface PXE expansion ROM.
Management Ports Expansion ROM	Disabled PXE	The Management Ports PXE Expansion ROM on the face plate can be enabled/disabled. If disabled, remote LAN boot via the management ports on the face plate is not available to boot the system.	Enabled: Initializes Management Ports PXE expansion ROM. Disabled: Management Ports PXE expansion ROM not used. If disabled, remote LAN boot via Management Ports is not available to boot the system!
RTM Expansion ROM	Enabled Disabled	The RTM Expansion ROM can be enabled/disabled. If disabled, any SAS devices attached to the RTM are not available to boot the system.	Enabled: Initializes RTM expansion ROM. Disabled: RTM expansion ROM not used. If disabled, any SAS devices attached to the RTM are not available to boot the system!
AMC Slot Expansion ROM	Enabled Disabled	Enables or disables AMC Slot Expansion ROM(s), if any detected. If disabled, AMC Expansion ROM(s) code will not be executed during POST.	Enabled: Initializes AMC slot expansion ROM. Disabled: AMC slot expansion ROM not used.
Update Channel Expansion ROM	Enabled Disabled	Enables or disables Update Channel Expansion ROM(s), if any detected. If disabled, Update Channel Expansion ROM(s) code will not be executed during POST	Enabled: Initializes Update Channel expansion ROM. Disabled: Update

5.1.4.6 PCI Express Configuration sub-menu

Feature	Option	Description	Help text
RTM Hot Plug Support	Enabled Disabled	RTM hot plug support can be enabled/ disabled.	Enabled: Hot Plug for RTM available. Disabled: Hot Plug for RTM not available. Note: Need Power Cycle with any changes.
AMC Slot Hot Plug Support	Enabled Disabled	AMC slot hot plug support can be enabled/ disabled.	Enabled: Hot Plug for AMC slot available. Disabled: Hot Plug for AMC slot not available. Note: Need Power Cycle with any changes.
Force Gen1 on AMC	Enabled Disabled	Setting this to Enabled will force AMC in Gen1 Mode. Gen 2 will not be used.	Setting this to Enabled will force AMC in Gen1 Mode.
Relaxed Ordering	Auto Disabled Enabled	The Relaxed Ordering attribute is applicable and permitted to be Set with AtomicOp Requests, where it affects the ordering of both the Requests and their associated Completions.	Enables/Disables PCI Express Device Relaxed Ordering.
Maximum Payload Size	Auto 128 Bytes 256 Bytes 512 Bytes 1024 Bytes 2048 Bytes 4096 Bytes	This field sets maximum TLP payload size for the Function. As a Receiver, the Function must handle TLPs as large as the set value. As a Transmitter, the Function must not generate TLPs exceeding the set value.	Set Maximum Payload of PCI Express Device or allow System BIOS select the value.
Extended Tag Field	Auto Disabled Enabled	Enables a Function to use an 8-bit Tag field as a Requester. If the bit is Clear, the Function is restricted to a 5-bit Tag field.	If ENABLED, allows Devoce to use 8-bit TAG field as a requester.
No Snoop	Auto Disabled Enabled	The No Snoop attribute is applicable and permitted to be Set with AtomicOp Requests, but atomicity must be guaranteed regardless of the No Snoop attribute value	Enables/Disables PCI Express Device No Snoop option.
Maximum Read Request Size	Auto 128 Bytes 256 Bytes 512 Bytes 1024 Bytes 2048 Bytes 4096 Bytes	This field sets the maximum Read Request size for the Function as a Requester. The Function must not generate Read Requests with size exceeding the set value.	Set Maximum Read Request Size of PCI Express Device or allow System BIOS select the value.
Extended Synch	Auto Disabled Enabled	When Enabled, this bit forces the transmission of additional Ordered Sets when exiting the L0s state and when in the Recovery state. This mode provides external devices (e.g., logic analyzers) monitoring the Link time to achieve bit and Symbol lock before the Link enters the L0 state and resumes communication.	If ENABLED, allows generation of Extended Synchronization patterns.

5.1.4.7 USB Configuration sub-menu

Feature	Option	Description	Help text
USB 2.0 Controller Mode	FullSpeed HiSpeed	Configures the USB 2.0 Controller in HiSpeed (480Mbps) or FullSpeed (12Mbps).	FullSpeed: 12 Mbps HiSpeed: 480 Mbps
BIOS EHCI Hand-Off	Enabled Disabled	A workaround for OSes without EHCI hand-off support can be enabled/disabled. The EHCI ownership change should be claimed by an EHCI driver.	Enabled: EHCI hand-off support enabled. Disabled: EHCI hand-off support disabled.
USB Mass Storage Device Configuration (only present if USB Mass Storage detected)	N/A	Selects sub-menu.	Configure the USB Mass Storage Class Devices.

5.1.4.8 USB Mass Storage Device Configuration sub-menu

Feature	Option	Description	Help text
Device #1-6		Mass Storage Device identification	
Emulation Type (for each devices)	Auto Floppy Forced FDD Hard Disk CDROM	If Auto, USB devices less than 530MB will be emulated as Floppy and remaining as hard drive. Forced FDD option can be used to force a HDD formatted drive to boot as FDD (Ex. ZIP drive).	If Auto, USB devices less than 530MB will be emulated as Floppy and remaining as hard drive. Forced FDD option can be used to force a HDD formatted drive to boot as FDD.

5.1.4.9 Advanced Chipset Control sub-menu

Feature	Option	Description	Help text
CPU Bridge Configuration	N/A	Select sub-menu	N/A
Northbridge Configuration	N/A	Select sub-menu	N/A
Spread Spectrum Clocking Mode	Enabled Disabled	Allows BIOS to set Clock Spread Spectrum for EMI (electromagnetic interference) control.	Enabled: Allows setting of Clock Spread Spectrum for EMI control. Disabled: Denies setting of Clock Spread Spectrum for EMI control.

5.1.4.9.1 CPU Bridge Configuration sub-menu

Feature	Option	Description	Help text
CPU Revision	N/A	Display CPU revision ID.	Show only
Current QPI Frequency	N/A	Display Current QPI frequency speed in GT/s	Show only
Current Memory Frequency	N/A	Display current memory speed (DDR-3) in MHz	Show only
DDR3 2x Refresh Rate	Disabled Enabled		Allows override selection of the DDR3 refresh rate for normal operation. Enabled use the 2x refresh rate for high temperature. Disabled use normal 1x refresh rate.

5.1.4.9.2 Northbridge Configuration sub-menu

Feature	Option	Description	Help text
NB Revision	N/A	Display Current NB revision ID.	Show only
Current QPI Frequency	N/A	Display Current QPI frequency speed in GT/s	Show only
Intel QuickData Technology / DMA	Enabled Disabled	Enable special setting to made available the Direct Memory Access.	Intel QuickData Technology / Direct Memory Access configuration.
Intel QuickData Technology / DCA	Enabled Disabled	Enable special setting to made available the Direct Cache Access.	Intel QuickData Technology / Direct Cache Access configuration.

5.1.4.10 Intel VT-d Configuration Sub-Menu

Feature	Option	Description	Help text
Intel VT-d	Enabled Disabled	Enable VT-d feature from INTEL. This will add DMAR table in ACPI to allows supporting OS to take advantage of the Virtualization Technology for Directed I/O.	Enabled: allow DMAR table to be present in ACPI table for virtualization. Disabled: DMAR table is not present.

5.1.4.11 I/O Virtualization Sub-Menu

Feature	Option	Description	Help text
SR-IOV Supported	Disabled Enabled		Options Disabled Enabled

5.1.5 Security Menu

Feature	Option	Description	Help text
Supervisor Password	Installed Not Installed	Indicates the status of the Supervisor Password.	Indicates the status of the supervisor password.
User Password	Installed Not Installed	Indicates the status of the User Password.	Indicates the status of the user password.
Set Supervisor Password	Enter	The supervisor password can be installed or changed.	Install or change the supervisor password.
Set User Password	Enter	The user password can be installed or changed.	Install or change the user password.
Clear User Password	Enter	Immediately clears the User password.	Clears user password.
User Access Level	No Access View Only Limited Full Access	Controls the user access level to the BIOS Setup utility. Supervisor has full access to the BIOS Setup utility. No Access: Prevents user access to the setup utility. View Only: Allows read only user access to the setup utility i.e. none of the fields can be changed. Limited: Allows limited fields such as date and time to be changed in user access to the setup utility. Full Access: Allows unlimited user access to the setup utility.	Controls access to the setup utility. No Access: Prevents user access. View Only: Allows read only user access. Limited: Allows limited fields to be changed. Full Access: Allows unlimited user access.
Execute Disable Bit	Enabled Disabled	Execute Disable Bit allows the processor to classify areas in memory by where application code can execute and where it cannot preventing certain classes of malicious buffer overflow attacks when combined with a supporting operating system.	Enabled: Allows processor to prevent application code access to certain memory areas. Needs supporting OS. Disabled: No restrictions to application code memory area access by processor.

5.1.6 Boot Menu

Feature	Option	Description	Help text
Boot Settings Configuration	N/A	Selects sub-menu.	Selects boot settings configuration.
Boot Device Priority	N/A	Selects sub-menu.	Selects boot device priority.
Hard Disk Drives	N/A	Selects sub-menu.	Lists available hard disk drives in priority order.
Removable Drives	N/A	Selects sub-menu.	Lists available removable disk drives in priority
CD/DVD Drives	N/A	Selects sub-menu.	Lists available CD/DVD drives in priority order.
USB Drives	N/A	Selects sub-menu.	Lists available USB drives in priority order.
Network Drives	N/A	Selects sub-menu.	Lists available network drives in priority order.
Other Drives	N/A	Selects sub-menu.	Lists available other drives in priority order.

5.1.6.1 *Boot Settings Configuration sub-menu*

Feature	Option	Description	Help text
Quick Boot Mode	Enabled Disabled	Allows/denies skipping the memory tests during a cold boot. Quick Boot enabled has no impact on a warm reset boot since then memory is not initialized during a warm reset.	Enabled: Allows skipping the memory tests during a cold boot. Disabled: Allows the extended memory test to be executed during a cold boot.
Progressive Boot	Enabled Disabled	If disabled, the normal boot path is used. If enabled, IPMI need to be enabled. The OS Load Timeout watchdog will be enabled at time selected by user. If OS load WD is disabled, it will be re-enabled by progressive boot.	Enabled: Allows BIOS to bypass a failing device upon WD bite. Note: If OS Load is set to disable this option will enable WD at 600 seconds.
Progressive Boot Action	Reset sequence Keep booting	If value is set to Reset sequence, the boot order is reset upon good start from a device without any WD bite. If value is set to Keep booting, the boot sequence keep the failing device and boot from the next.	Reset sequence: Boot sequence is reset after a good start from a device. Keep booting: Boot sequence start from last successful bootable device.
Warm Reset Initial count	Never Always 5 10 15	Never does Cold reset. Always always do a warm reset after the first Cold boot. The rest of the option are count for warm reset.	Select the value of the warm reset count. Always: Always do a warm reset. Never: Always do a cold reset.
Default Reset Type	Hard Reset Warm Reset		Sets the reset type issued whenever front panel reset button is pushed or IPMI Watchdog expires with reset action configured.

5.1.6.2 *Boot Device Priority sub-menu*

Feature	Option	Description	Help text
1st Boot Device	Type: Boot device	Specifies the priority of the available boot sources. The list includes USB CD ROM, USB Hard Drive, SAS Hard Drive and PXE. Other supported devices might be dynamically added	Specifies the priority of the available boot sources.
		...	
Nth Boot Device	Type: Boot device	Specifies the boot priority of the available boot sources. The list includes USB CD ROM, USB Hard Drive, SAS Hard Drive and PXE. Other supported devices might be dynamically added	Specifies the priority of the available boot sources.

5.1.6.3 *Hard Disk Drives sub-menu*

Feature	Option	Description	Help text
1st Drive	Varies	Specifies the boot priority of the available Hard Disk devices.	Specifies the boot priority of the available devices. Select the boot device with UpArrow or DownArrow key. Press Enter to set the selection as the intended boot device.
...			
Nth Drive	Varies	Specifies the boot priority of the available Hard Disk devices.	Specifies the boot priority of the available devices. Select the boot device with UpArrow or DownArrow key. Press Enter to set the selection as the intended boot device.

5.1.6.4 *Removable Drives sub-menu*

Feature	Option	Description	Help text
1st Drive	Varies	Specifies the boot priority of the available Removable devices.	Specifies the boot priority of the available devices. Select the boot device with UpArrow or DownArrow key. Press Enter to set the selection as the intended boot device.
...			
Nth Drive	Varies	Specifies the boot priority of the available Removable devices.	Specifies the boot priority of the available devices. Select the boot device with UpArrow or DownArrow key. Press Enter to set the selection as the intended boot device.

5.1.6.5 *CD/DVD Drives sub-menu*

Feature	Option	Description	Help text
1st Drive	Varies	Specifies the boot priority of the available CD or DVD devices.	Specifies the boot priority of the available devices. Select the boot device with UpArrow or DownArrow key. Press Enter to set the selection as the intended boot device.
...			
Nth Drive	Varies	Specifies the boot priority of the available CD or DVD devices.	Specifies the boot priority of the available devices. Select the boot device with UpArrow or DownArrow key. Press Enter to set the selection as the intended boot device.

5.1.6.6 *USB Disk Drives sub-menu*

Feature	Option	Description	Help text
1st Drive	Varies	Specifies the boot priority of the available USB Disk devices.	Specifies the boot priority of the available devices. Select the boot device with UpArrow or DownArrow key. Press Enter to set the selection as the intended boot device.
...			
Nth Drive	Varies	Specifies the boot priority of the available USB Disk devices.	Specifies the boot priority of the available devices. Select the boot device with UpArrow or DownArrow key. Press Enter to set the selection as the intended boot device.

5.1.6.7 *Network Disk Drives sub-menu*

Feature	Option	Description	Help text
1st Drive	Varies	Specifies the boot priority of the available Network Disk devices.	Specifies the boot priority of the available devices. Select the boot device with UpArrow or DownArrow key. Press Enter to set the selection as the intended boot device.
...			
Nth Drive	Varies	Specifies the boot priority of the available Network Disk devices.	Specifies the boot priority of the available devices. Select the boot device with UpArrow or DownArrow key. Press Enter to set the selection as the intended boot device.

5.1.6.8 *All Other Disk Drives sub-menu*

Feature	Option	Description	Help text
1st Drive	Varies	Specifies the boot priority of any other available devices (other than Hard Disk, Removable, CD/DVD, USB disk or Network).	Specifies the boot priority of the available devices. Select the boot device with UpArrow or DownArrow key. Press Enter to set the selection as the intended boot device.
...			
Nth Drive	Varies	Specifies the boot priority of any other available devices (other than Hard Disk, Removable, CD/DVD, USB disk or Network).	Specifies the boot priority of the available devices. Select the boot device with UpArrow or DownArrow key. Press Enter to set the selection as the intended boot device.

5.1.7 System Management Menu

Feature	Option	Description	Help text
Remote Access Configuration	N/A	Selects sub-menu.	N/A
Set LAN Configuration	N/A	Selects sub-menu.	IPMI over LAN (and Serial Over LAN).
Watchdog Timers	N/A	Selects sub-menu.	N/A
System Information	N/A	Selects sub-menu.	N/A
Managed FRU Deactivation Policies	N/A	Selects sub-menu.	N/A
OEM e-keying Configuration	N/A	Selects sub-menu.	N/A

5.1.7.1 Remote Access Configuration sub-menu

Feature	Option	Description	Help text
Serial Port Number	COM1 COM2	Configures serial port for console redirection. Also used for Headless operation mode through ACPI.	Select serial port for console redirection.
Serial Port 1 I/O address	3F8/IRQ4	Displays the hardware address of the COM 1 port.	N/A, display only.
Serial Port 2 I/O address	2F8/IRQ3	Displays the hardware address of the COM 2 port i.e. RTM serial port.	N/A, display only.
Baud Rate	115200 8,n,1 57600 8,n,1 38400 8,n,1 19200 8,n,1 9600 8,n,1	Configures serial port Baud rate for both serial ports.	Select serial port Baud rate.
Flow Control	Hardware Software None	Configures flow control for console redirection for both serial ports.	Select flow control for console redirection.
Terminal Type	ANSI VT100 VTUTF8	Configures the type of console emulation used for both serial ports.	Select the type of console emulation used.
Terminal Size	80x24	Displays terminal size.	N/A, display only.

5.1.7.2 Set LAN Configuration sub-menu

Feature	Option	Description	Help text
Channel Number	01 or 02	Each interface has a channel number that is used when configuring the channel and for routing messages between channels. Channels 01 and 02 on Base interface are available. The channel number assignments are described in IPMI Specification 2.0, table 6-1.	Enter Channel Number for SET LAN Config Command. Proper value 01 or 02.
Channel Status	Valid or Invalid	Display Valid if IPMC support LAN Channel.	N/A, display only.
IP Address	N/A	Selects sub-menu.	Enter for IP Address Configuration.
MAC Address	N/A	Selects sub-menu.	Enter for MAC Address Configuration.
Subnet Mask	N/A	Selects sub-menu.	Enter for Subnet Mask Configuration.
Gateway Address	N/A	Selects sub-menu.	Enter for Gateway IP Address Configuration.
VLAN ID	N/A	Selects sub-menu.	Enter for VLAN ID Configuration.
VLAN Priority	N/A	Selects sub-menu.	Enter for VLAN Priority Configuration.
Active LAN Channel Number	None 01 02 Both	Each interface has a channel number that is used when configuring the channel and for routing messages between channels. The channel number assignments are described in IPMI Specification 2.0, table 6-1.	Enter Active LAN Channel Number for Set LAN Configuration Command.

5.1.7.3 IP Configuration sub-menu

Feature	Option	Description	Help text
LAN Parameter Selector	03	The parameter selector assignments are described in IPMI Specification 2.0, table 23-4. Selector #03: IP Address.	N/A, display only.
Channel Number	01 or 02	Each interface has a channel number that is used when configuring the channel and for routing messages between channels. Channels 01 and 02 on Base interface are available. The channel number assignments are described in IPMI Specification 2.0, table 6-1.	Enter Channel Number for SET LAN Config Command. Proper value 01 or 02.
Channel Status	Valid or Invalid	Display Valid if IPMC support LAN Channel.	N/A, display only.
IP Address Source	Static or DHCP	Select whether IP Address is set Static or retrieve using DHCP.	Select IP Address Source: Static or DHCP
Current IP Address	xxx.xxx.xxx.xxx	Display the current LAN configuration stored in IPMI NVRAM for IPMI LAN.	N/A, display only.
IP Address	xxx.xxx.xxx.xxx	This allows setting an IP Address for LAN configuration when IP Address Source is set to static. This option is hidden when DHCP source is selected.	Enter IP Address in decimal in the form of XXX.XXX.XXX.XXX (XXX less than 256 and in decimal only).

5.1.7.4 *MAC Address Configuration sub-menu*

Feature	Option	Description	Help text
LAN Parameter Selector	05	The parameter selector assignments are described in IPMI Specification 2.0, table 23-4. Selector #05: MAC Address.	N/A, display only.
Channel Number	01 or 02	Each interface has a channel number that is used when configuring the channel and for routing messages between channels. Channels 01 and 02 on Base interface are available. The channel number assignments are described in IPMI Specification 2.0, table 6-1.	Enter Channel Number for SET LAN Config Command. Proper value 01 or 02.
Channel Status	Valid or Invalid	Display Valid if IPMC support LAN Channel.	N/A, display only.
Current MAC Address	xx.xx.xx.xx.xx.x x	Display the current MAC Address stored in IPMI NVRAM for IPMI LAN.	N/A, display only.

5.1.7.5 *Subnet Mask Configuration sub-menu*

Feature	Option	Description	Help text
LAN Parameter Selector	06	The parameter selector assignments are described in IPMI Specification 2.0, table 23-4. Selector #06: Subnet Mask.	N/A, display only.
Channel Number	01 or 02	Each interface has a channel number that is used when configuring the channel and for routing messages between channels. Channels 01 and 02 on Base interface are available. The channel number assignments are described in IPMI Specification 2.0, table 6-1.	Enter Channel Number for SET LAN Config Command. Proper value 01 or 02.
Channel Status	Valid or Invalid	Display Valid if IPMC support LAN Channel.	N/A, display only.
IP Address Source	Static or DHCP	Select whether IP Address is set static or retrieve using DHCP.	Select IP Address Source: Static or DHCP
Current Subnet Mask	xxx.xxx.xxx.xxx	Display the current Subnet Mask configuration stored in IPMI NVRAM for IPMI LAN.	N/A, display only.
Subnet Mask	xxx.xxx.xxx.xxx	This allows setting of a Subnet Mask for LAN configuration when IP Address Source is set to static. This option is hidden when DHCP source is selected.	Enter Subnet Mask in decimal in the form of XXX.XXX.XXX.XXX (XXX less than 256 and in decimal only).

5.1.7.6 Gateway Address Configuration sub-menu

Feature	Option	Description	Help text
LAN Parameter Selector	12	The parameter selector assignments are described in IPMI Specification 2.0, table 23-3. Selector #12: Default Gateway Address.	N/A, display only.
Channel Number	01 or 02	Each interface has a channel number that is used when configuring the channel and for routing messages between channels. Channels 01 and 02 on Base interface are available. The channel number assignments are described in IPMI Specification 2.0, table 6-1.	Enter Channel Number for SET LAN Config Command. Proper value 01 or 02.
Channel Status:	Valid or Invalid	Display Valid if IPMC support LAN Channel.	N/A, display only.
IP Address Source	Static or DHCP	Select whether IP Address is set static or retrieve using DHCP.	Select IP Address Source: Static or DHCP
Current Gateway Address:	xxx.xxx.xxx.xxx	Display the current Gateway configuration stored in IPMI NVRAM for IPMI LAN.	N/A, display only.
Gateway Address	xxx.xxx.xxx.xxx	This allows setting an Gateway IP Address for LAN configuration when IP Address Source is set to static. This option is hidden when DHCP source is selected.	Enter Gateway IP Address in decimal in the form of XXX.XXX.XXX.XXX (XXX less than 256 and in decimal only).

5.1.7.7 VLAN ID Configuration

Feature	Option	Description	Help text
LAN Parameter Selector	20	The parameter selector assignments are described in IPMI Specification 2.0, table 23-4. Selector #20: 802.1q VLAN ID (12-bit).	N/A, display only.
Channel Number	01 or 02	Each interface has a channel number that is used when configuring the channel and for routing messages between channels. Channels 01 and 02 on Base interface are available. The channel number assignments are described in IPMI Specification 2.0, table 6-1.	Enter Channel Number for SET LAN Config Command. Proper value 01 or 02.
Channel Status:	Valid or Invalid	Display Valid if IPMC support LAN Channel.	N/A, display only.
802.1q VLAN ID Value	xxx	This allows setting an 802.1q VLAN ID for LAN configuration.	Enter VLAN ID value in decimal. VLAN ID must be between 1 and 4094.
Current 802.1q VLAN ID Value:	xxxx	Display the current 801.1q VLAN ID configuration stored in IPMI NVRAM for IPMI LAN.	N/A, display only.
Support VLAN Tagged Packets	Enabled Disabled	Select if 802.1q VLAN tagged packets are added.	Select if VLAN Tagged Packets are to be added or not.
VLAN Tagged Packets Status:	Enabled or Disabled	Display the current status of the 801.1q VLAN tagged packets configuration stored in IPMI NVRAM for IPMI LAN.	N/A, display only.

5.1.7.8 VLAN Priority Configuration

Feature	Option	Description	Help text
LAN Parameter Selector	21	The parameter selector assignments are described in IPMI Specification 2.0, table 23-4. Selector #21: 802.1q VLAN Priority.	N/A, display only.
Channel Number	01 or 02	Each interface has a channel number that is used when configuring the channel and for routing messages between channels. Channels 01 and 02 on Base interface are available. The channel number assignments are described in IPMI Specification 2.0, table 6-1.	Enter Channel Number for SET LAN Config Command. Proper value 01 or 02.
Channel Status:	Valid or Invalid	Display Valid if IPMC support LAN Channel.	N/A, display only.
802.1q VLAN Priority Value	x	This allows setting an 802.1q VLAN priority for LAN configuration.	Enter VLAN Priority value in decimal. Proper value below 8.
Current VLAN Priority Value:	x	Display the current 801.1q VLAN Priority configuration stored in IPMI NVRAM for IPMI LAN.	N/A, display only.

5.1.7.9 Watchdog Timer sub-menu

Feature	Option	Description	Help text
BIOS POST Timeout	Disabled 60 120 150 300 600	Configures the BIOS POST IPMI HW watchdog timeout value in seconds. The BIOS POST watchdog will be disabled if the timeout value is set 0.	Select the BIOS POST IPMI HW watchdog timeout value.
BIOS POST Action	No Action Hard Reset Power Down Power Cycle	Configures which action to take when the BIOS POST IPMI HW watchdog expires.	Select which action to take when the BIOS POST IPMI HW watchdog expires.
OS Load Timeout	Disabled 15 30 45 60 90 120 150 300 600	Configures the OS Load IPMI HW watchdog timeout value in seconds. The OS Load watchdog will be disabled if the timeout value is set 0.	Select the OS Load IPMI HW watchdog timeout value.
OS Load Action	No Action Hard Reset Power Down Power Cycle	Configures which action to take when the OS Load IPMI HW watchdog expires.	Select which action to take when the OS Load IPMI HW watchdog expires.

5.1.7.10 *System Information sub-menu*

Feature	Option	Description	Help text
Board Product Name	AT8050	Displays the CPU blade product name.	N/A, display only.
Board Vendor	Kontron	Displays CPU blade vendor.	N/A, display only.
Board Serial Number	Varies	Displays the CPU blade serial number.	N/A, display only.
Board Part Number	Varies	Displays the CPU blade part number.	N/A, display only.
Chassis Slot	1..16	Displays the current chassis slot number for the CPU blade.	N/A, display only.
BIOS In Use	Primary Secondary	Displays the current BIOS device in use (primary or secondary).	The current BIOS device in use (primary or secondary).
IPMI Device and FW Info	N/A	Selects sub-menu.	N/A, display only.

5.1.7.11 IPMI Device and FW Info sub-menu

Feature	Option	Description	Help text
IPMI Version	2.0	Displays IPMI Specification version.	N/A, display only.
IPMI Device ID	Varies	Displays IPMI device ID. OEM defined, IPMI Device ID has been assigned like this: Renesas H8S2148 = 1 Kontron PMM = 2 Renesas H8S2145 = 3 Renesas H8S2166 = 4 Renesas H8S2138 = 5 Renesas H8S2168 = 6 Renesas H8S2472 = 7	N/A, display only.
IPMI Device Revision	Varies	Displays IPMI device revision. OEM defined, specify the version of the IPMI Device controller.	N/A, display only.
IPMI Firmware Version	Varies	Displays IPMI firmware version.	N/A, display only.
SDR Revision	Varies	Displays SDR (Sensor Data Record) revision. This field correspond to the implementation specific auxiliary information from IPMI "Get Device ID Command", byte 13. The SDR revision is displayed in decimal notation.	N/A, display only.
Maintenance Revision	Varies	Displays Maintenance revision. This field correspond to the implementation specific auxiliary information from IPMI "Get Device ID Command", byte 15. The byte is displayed as a 2-digit hexadecimal number.	N/A, display only.
Aux Revision Info byte 0	Varies	Displays implementation specific auxiliary information from IPMI "Get Device ID Command", byte 13. The byte is displayed as a 2-digit hexadecimal number.	N/A, display only.
Aux Revision Info byte 1	Varies	Displays implementation specific auxiliary information from IPMI "Get Device ID Command", byte 14. The byte is displayed as a 2-digit hexadecimal number.	N/A, display only.
Aux Revision Info byte 2	Varies	Displays implementation specific auxiliary information from IPMI "Get Device ID Command", byte 15. The byte is displayed as a 2-digit hexadecimal number.	N/A, display only.
Aux Revision Info byte 3	Varies	Displays implementation specific auxiliary information from IPMI "Get Device ID Command", byte 16. The byte is displayed as a 2-digit hexadecimal number.	N/A, display only.

5.1.7.12 OEM e-keying Configuration sub-menu

Feature	Option	Description	Help text
PCI Express SSC Setting	Enabled Disabled	PCI Express Spread Spectrum Clock Mode support can be SSC/Non-SSC.	Select the PCI Express Spread Spectrum Clock "SSC" Mode. Warning! Re-insert the blade after changing the PCI Express Clock Mode. This is used for AMC.1 module e-keying.
PCI Express SSC State	Enabled Disabled	Display actual AMC PCI Express Spread Spectrum Clock Mode.	N/A
Upd. Channel Override Setting	Disabled Auto Enabled	Route Update Channel PCI Express.	Disabled: disable PCIe port and PCIe clock. Enabled: enable PCIe port and PCIe clock Auto: enable PCIe based on e-keying. Warning! Reinsert the blade after changing settings.
Upd. Channel Override State	Disabled Auto Enabled	Display actual Update Channel PCI Express Routing.	N/A
Management LAN Setting	Disabled Front Panel AMC.2 Module RTM Fabric Interface	Route Management LAN to the selected destination.	Selects where the Management LAN ports are routed. Warning! Reinsert the blade after changing settings.
Management LAN State	Disabled Front Panel AMC.2 Module RTM Fabric Interface	Display actual Management LAN Routing.	N/A
AMC P8-11 Setting	Disabled Fabric Interface	Route AMC port 8-11 to Fabric or disable.	Disabled: AMC.2 module is not connected to Fabric Interface. FI: allow AMC.2 module connection to FI. When this option is enabled, the i82599EB cannot be used on the FI.Warning! Re-insert the blade after changing settings.
AMC P8-11 State	Disabled Fabric Interface	Display actual AMC Port 8-11 Routing.	N/A
RTM Serial Port Setting	CPU COM2 AMC P15	Route AMC port 15 to RTM or disable.	Select which Serial Port is routed to the RTM Serial Port connector. An e-keying match is required between the AMC and the RTM for the serial link to work. Warning! Re-insert the blade after changing settings.

Feature	Option	Description	Help text
RTM Serial Port State	CPU COM2 AMC P15	Display actual RTM Serial Port Routing.	N/A
ICH SATA P0 Setting	Disabled AMC	Route ICH SATA P0 to AMC or disable	Select AMC to connect a SATA disk in the AMC to the ICH controller. Select Disabled to route AMC to the RTM SAS controller. Warning! Re-insert the blade after changing settings.
ICH SATA P0 State	Disabled AMC	Display actual ICH SATA P0 Routing.	N/A
AMC PCI Express Setting	Disabled Auto	Route AMC PCIe based on e-keying or disabled	Disabled: Disable AMC PCI Express. Auto: Enable AMC PCI Express based on e-keying. Warning! Re-insert the blade after changing settings.
AMC PCI Express State	Disabled Auto	Display actual AMC PCI Express	N/A

5.1.7.13 *Managed FRU Deactivation Policies sub-menu*

Feature	Option	Description	Help text
On AMC Deactivation (FRU1)	Deactivate FRU0 Deactivate FRU1	AMC Deactivation Policy. Deactivate AMC only or Gracefull Shutdown Front Board	Select FRU0 to shutdown the board or FRU1 for AMC.
On RTM Deactivation (FRU2)	Deactivate FRU0 Deactivate FRU2	RTM Deactivation Policy. Deactivate RTM only or Gracefull Shutdown Front Board	Select FRU0 to shutdown the board or FRU2 for RTM.
On RTM Disk Deactivation (FRU3)	Deactivate FRU0 Deactivate FRU3	RTM Disk Deactivation Policy. Deactivate RTM Disk only or Gracefull Shutdown Front Board.	Select FRU0 to shutdown the board or FRU3 for RTM disk.

5.1.8 Exit Menu

Feature	Option	Description	Help text
Exit Saving Changes	N/A	Saves modified settings into non-volatile memory and reboots the system.	Exit system setup saving changes to non-volatile memory.
Exit Discarding Changes	N/A	Discards modifications to settings and reverts to the state when Setup was entered, then complete remaining POST.	Exit system setup without saving changes.
Load Setup Defaults	N/A	Loads the factory default settings.	Load default settings.
Discard Changes	N/A	Discards modifications to settings and reverts to the state when Setup was entered.	Discard changes without exiting setup.
Exit & Execute BIOSRollback	N/A	Exits the Setup utility without saving any changes and then performs a Rollback of the on-board BIOS chips. If the currently executing BIOS was the primary BIOS, the system would change to the backup BIOS (and vice versa).	Rollback BIOS without saving any changes.

5.2 Boot Utilities

AMI Boot Utilities are: Boot Menu POP-UP

Boot Menu POP-UP is a boot screen that displays a selection of boot devices from which you can boot your operating system.

5.2.1 Entering BIOS Setup Menu

Pressing (or <F4> from a console redirection) during POST enters BIOS Setup.

5.2.2 Boot Menu POP-UP

Pressing <F11> (or <F3> from a Console Redirection terminal) displays the Boot Menu POP-UP with these options:

- 1 Load the operating system from a boot device of your choice.
- 2 Exit the Boot Menu POP-UP (with <ESC>) and load the operating system from the boot devices in the order specified in Setup.

5.2.3 SAS Option ROM

To access the SAS Option ROM, follow the procedure listed below.

- 1 Option ROM for SAS needs to be enabled and the RTM must be present.
- 2 Press "F3" to select the boot device.
- 3 Press "CTRL-C" during the execution of the option ROM.

4 BIOS mention: "Please wait, invoking SAS Configuration Utility..."

LSI Corp Configuration Utility will load after initialization"

5 Select "SCSI:LSI MPI Boot Support" in Popup menu

The menu is now available.

5.2.4 BOOT Menu POP-UP

The BOOT Menu POP-UP expands your boot options by letting you choose your boot device, which could be a hard disk, floppy disk, CDRom, Flash Disk, SCSI or LAN. You can select your boot device in Setup, or you can choose a different device each time you boot during POST by selecting your boot device in the Boot device <F11> (or <F3> from a Console Redirection terminal).

5.3 Console Redirection (VT100 Mode)

The VT100 operating mode allows remote setup of the board. This configuration requires a remote terminal that must be connected to the board through a serial communication link.

5.3.1 Requirements

The terminal should emulate a VT100 or an ANSI terminal. Terminal emulation programs such as Telix®, HyperTerminal(Windows), minicom(Linux) or ProComm®(Windows) can also be used.

5.3.2 ANSI and VT100 Keystroke Mapping

Up	<ESC>[A
Down	<ESC>[B
Right	<ESC>[C
Left	<ESC>[D
Home	<ESC>[H
End	<ESC>[K
F1	<ESC>OP
F2	<ESC>OQ
F3	<ESC>OR
F4	<ESC>OT

5.3.3 VT-UTF8 Keystroke Mapping

The following "escape sequences" are defined in the "Conventions for Keys Not in VT100 Terminal Definition and ASCII Character Set" section of "Standardizing Out-of-Band Management Console Output and Terminal Emulation (VT-UTF8 and VT100+)", available for download at microsoft.com.

F1 Key	<ESC>1
F2 Key	<ESC>2
F3 Key	<ESC>3
F4 Key	<ESC>4
F5 Key	<ESC>5
F6 Key	<ESC>6
F7 Key	<ESC>7
F8 Key	<ESC>8
F9 Key	<ESC>9
F10 Key	<ESC>0
F11 Key	<ESC>!
F12 Key	<ESC>@
Alt Modifier	<ESC>^A
Control Modifier	<ESC>^C
Home Key	<ESC>h
End Key	<ESC>k
Insert Key	<ESC>+
Delete Key	<ESC>-
Page Up Key	<ESC>?
Page Down Key	<ESC>/

These "escape sequences" are supported by VT-UTF8 compliant terminal connections, such as Windows Server 2003 Emergency Management Services (EMS).

AMIBIOS8 Serial Redirection supports these key sequences under two configurations:

- "Terminal Type" setup question is set to "VT-UTF8"
- "Terminal Type" setup question is set to "VT100" or "ANSI" and "VTUTF8 Combo Key Support" setup question is set to "Enabled"

Chapter 6

Thermal Considerations

6.1 Thermal Monitoring	117
------------------------------	-----

6. Thermal Considerations

The following chapter provide system integrators with the necessary information to satisfy thermal and airflow requirements when using the AT8050.

6.1 Thermal Monitoring

To ensure optimal operation and long-term reliability of the AT8050, all on-board components must remain within the maximum temperature specifications. The most critical components on the AT8050 are the processor, the memory modules and the chipset. Operating the AT8050 above the maximum operating limits will result in application performance degradation (e.g. the processor might throttles if it overheats) or may even damage the board. To ensure functionality at the maximum temperature, the blade supports several temperature monitoring and control features.

6.1.1 Heat Sinks

Multiple key components of the AT8050 are equipped with a specifically designed heat sink to ensure the best possible product for operational stability and long-term reliability. The physical size, shape, and construction of the heat sinks ensure the lowest possible thermal resistance. Moreover, the heat sinks were specifically designed to use forced airflow as found in ATCA systems.

6.1.2 Temperature Sensors

The AT8050 is equipped with 21 temperature sensors that are accessible via IPMI. Sensors are precisely positioned near critical components to accurately measure the on-board parts temperature. Temperature monitoring must be exercised to ensure highest possible level of system thermal management. An external system manager constitutes one of the best solution for thermal management, being able to report sensor status to end-user or manage events filters for example.

All sensors available on the AT8050, its RTM and the AMC can carry are listed into the Sensor Data Repository with their thresholds as defined by the PICMG 3.0 specification. The following extract (from the PICMG 3.0 Base Specification) details naming convention for thresholds as well as the meaning of each threshold level.

IPMI non-critical / PICMG 3.0 minor / telco minor:

Temperature is getting closer to operating limit; it is not really a "problem" yet. It's only a warning.

IPMI critical / PICMG 3.0 major / telco major:

Temperature is at or over normal operating limit, but not in destructive zone. Unit still operating but MTBF might be affected.

IPMI non-recoverable / PICMG 3.0 critical/ telco critical:

Temperature has reached a destructive level. Device might be damaged.

Most ATCA chassis react to temperature events in the following manner: When a minor threshold is reached, the shelf manager will incrementally increase airflow (fan speed) to bring the temperature below the crossed threshold. When a major threshold is reached, the shelf manager will increase the fans to maximum speed. When a critical threshold is reached, the shelf manager will shutdown the blade to prevent damage. The shelf alarm panel, when available, can inform the operator with LEDs when an alarm (minor, major, critical) is raised. Refer to your chassis documentation to adapt and optimize your temperature monitoring application to chassis capabilities. See also System Airflow section for more information.

Below is the list of temperature sensors with their respective thresholds.

Table 6-1:Temperature Sensors Thresholds

Sensor ID	Lower Thresholds			Upper Thresholds		
	Minor	Major	Critical	Minor	Major	Critical
Temp -48V A Feed	N/A	0°C	-10°C	+75°C	+85°C	+110°C
Temp -48V B Feed	N/A	0°C	-10°C	+75°C	+85°C	+110°C
Temp Mez 12V Out	N/A	0°C	-10°C	+75°C	+85°C	+110°C
Temp CPU	+5°C	0°C	-10°C	+77°C	TCC-5°C	+125°C
Temp Vcore	-35°C	-40°C	-50°C	+75°C	+85°C	+95°C
Temp VDDQ	-35°C	-40°C	-50°C	+75°C	+85°C	+95°C
Temp IOH	+10°C	+5	-5°C	+75°C	+85°C	+95°C
Temp ICH	+5°C	0°C	-10°C	+85°C	+95°C	+105°C
Temp Mngt Lan	+5°C	0°C	-10°C	+90°C	+100°C	+110°C
Temp BI Lan	+5°C	0°C	-10°C	+90°C	+100°C	+110°C
Temp FI Lan	+5°C	0°C	-10°C	+90°C	+100°C	+110°C
Temp IPMC	+5°C	0°C	-10°C	+90°C	+100°C	+110°C
Temp Bay Inlet	+5°C	0°C	-10°C	+75°C	+85°C	+95°C
Temp DIMM#1 (Channel 0, Dimm0)	+5°C	0°C	-10°C	+75°C	+85°C	+95°C
Temp DIMM#2 (Channel 0, Dimm1)	+5°C	0°C	-10°C	+75°C	+85°C	+95°C
Temp DIMM#3 (Channel1, Dimm0)	+5°C	0°C	-10°C	+75°C	+85°C	+95°C
Temp DIMM#4 (Channel 1, Dimm1)	+5°C	0°C	-10°C	+75°C	+85°C	+95°C
Temp DIMM#5 (Channel 2, Dimm0)	+5°C	0°C	-10°C	+75°C	+85°C	+95°C
Temp DIMM#6 (Channel 2, Dimm1)	+5°C	0°C	-10°C	+75°C	+85°C	+95°C

6.1.3 Airflow blockers

It is highly recommended to use airflow blockers (ATCA slot) and AMC airflow blocker in the AT8050 (or any empty AMC slot) to block any slot open to exterior air. Failure to do so would go against forced air principles applied on ATCA components, reducing system's cooling efficiency. Moreover, airflow blockers offer a higher impedance to forced air than typical board, who tend to let more air into slots filled with AT8050 or other ATCA boards.

6.1.4 System Airflow

The airflow impedance (pressure) curve gives multiple information and tips about thermal operational range of the system carrying the AT8050. Once volumetric airflow capability of your chassis is known, the PQ curve can help determine the ambient (room) temperature setpoint that should be used for optimal operation. If you are using various models of ATCA blades into the same chassis, it is possible to find the best thermal fit. Having the volumetric airflow value for each chassis slot, is it then possible to decide the layout using the pressure curves.

Table 6-2: Pressure curve AT8050 with AMC Filler

Test Poin	Airflow (CFM)	Pressure drop (in H2O)	Airflow (m ³ /h)	Pressure Drop (Pa)
1	12,04	0,038	20,46	9,57
2	15,03	0,048	25,54	12,02
3	21,02	0,069	34,00	17,28
4	25,00	0,100	42,48	24,91
5	30,01	0,142	50,99	35,26
6	35,02	0,195	59,50	48,61
7	40,02	0,257	68,00	64,07
8	45,06	0,321	76,55	79,95
9	50,01	0,381	84,97	95,00

Figure 6-1: Pressure Curve in Imperial

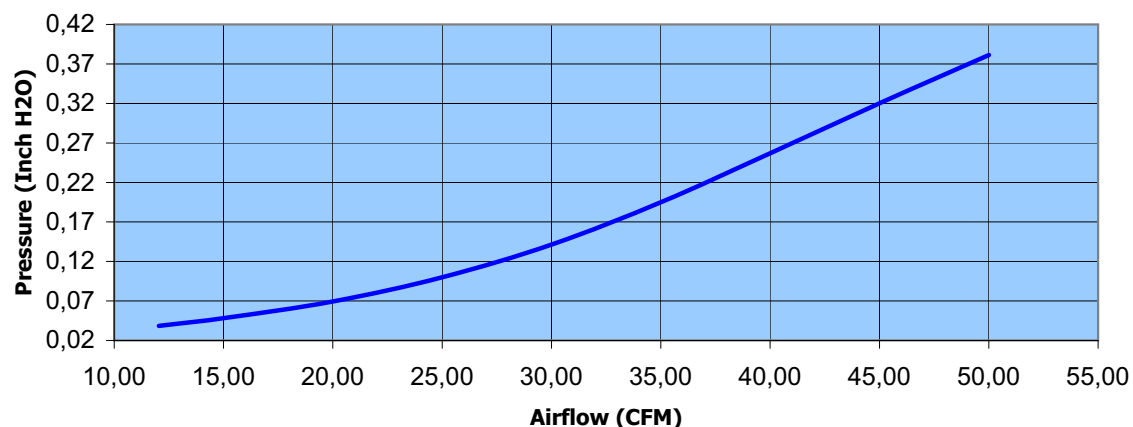
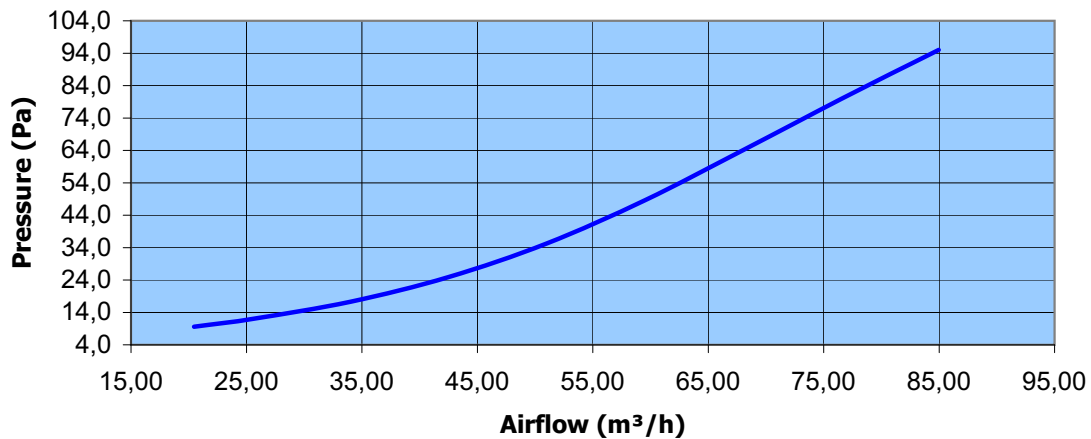

Figure 6-2: Pressure Curve in Metric



6.1.5 Thermal Profile

It is important to follow the thermal profile to make sure the MTBF values are respected. The CPU usage will influence the temperature that the case can handle. Refer to the figure below for more details.

Figure 6-3: CPU Thermal Profile

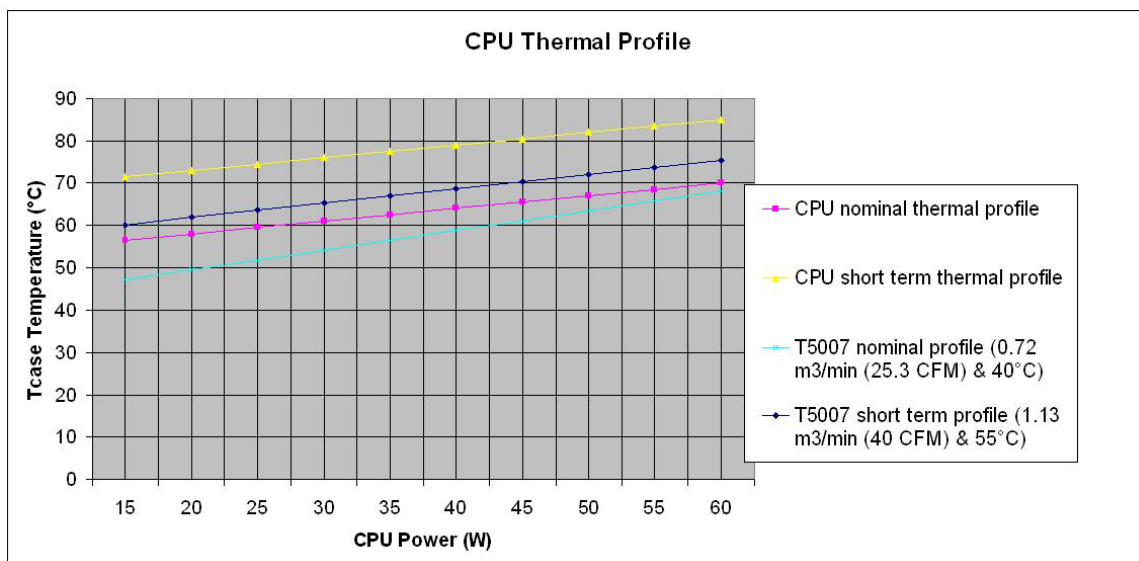

A. Memory & I/O Maps

A.1 Memory Mapping

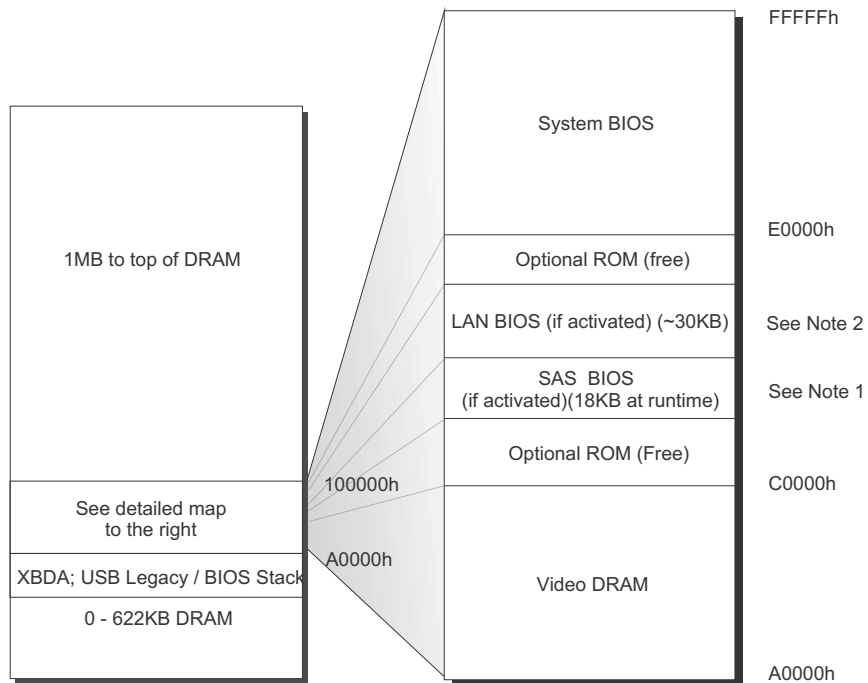

Note 1 : LAN BIOS address may vary

Note2: SAS BIOS address may vary.
Size is only 2KB if no device.

Address	Function
00000-9B7FF	0-622 KB DRAM
9B800-9FFFF	622KB - 640 KB XBDA; USB Legacy / BIOS Stack
A0000-BFFFF	Video DRAM
C0000-DBFFF	Optional ROM (Free) LAN BIOS around 30KB if activated, address may vary External Fiber Channel BIOS 18KB-64KB , address may vary
E0000-FFFFF	System BIOS
100000-PCI Memory	DRAM available

A.2 Kontron I/O Mapping

Address	Optional Address	Function
000-01F		DMA Controller 1
020-03F		Interrupt Controller 1
040-05F		Timer
060-06F		Keyboard
070-07F		Real-time clock
080-09F		DMA Page Register
0A0-0BF		Interrupt Controller 2
0C0-0DF		DMA Controller 2
0F0-0F1, 0F8-0FF		Math Coprocessor
1F0-1F7, 3F6		Primary IDE
170-177, 376		Secondary IDE
378-37F		Parallel Port (Used as PLD POD)
3F8-3FF (COM1)		Serial Port 1 (COM1 by default)
2F8-2FF (COM2)		Serial Port 2 (COM2 by default)
400-7FF		Chipset Reserved
800-9FF		Chipset Reserved
A00-A1F		Kontron Registers (on-board)

A.3 PCI IDSEL and Device Numbers

BUS#	DEV#	V. ID	D. ID	Funct. #	Description	PCI Description
00	00	8086	3406	0	Intel Corporation QuickPath Architecture I/O Hub to ESI Port (rev 10)	IOH
00	01	8086		0	Intel Corporation QuickPath Architecture I/O Hub PCI Express Root Port 1 (rev 10)	IOH
00	03	8086	340a	0	Intel Corporation QuickPath Architecture I/O Hub PCI Express Root Port 3 (rev 10)	IOH
00	04	8086	340b	0	Intel Corporation QuickPath Architecture I/O Hub PCI Express Root Port 4 (rev 10)	IOH
00	05	8086	340c	0	Intel Corporation QuickPath Architecture I/O Hub PCI Express Root Port 5 (rev 10)	IOH
00	07	8086	340e	0	Intel Corporation QuickPath Architecture I/O Hub PCI Express Root Port 7 (rev 10)	IOH
00	08	8086	340f	0	Intel Corporation QuickPath Architecture I/O Hub PCI Express Root Port 8 (rev 10)	IOH
00	09	8086	3410	0	Intel Corporation QuickPath Architecture I/O Hub PCI Express Root Port 9 (rev 10)	IOH
00	0a	8086	3411	0	Intel Corporation QuickPath Architecture I/O Hub PCI Express Root Port 10 (rev 10)	IOH
00	10	8086	3425	0	Intel Corporation QuickPath Interconnect Physical and Link Layer Registers Port 0 (rev 10)	IOH
00	10	8086	3426	1	Intel Corporation QuickPath Interconnect Routing and Protocol Layer Registers Port 0 (rev 10)	IOH
00	11	8086	3427	0	Intel Corporation QuickPath Interconnect Physical and Link Layer Registers Port 1 (rev 10)	IOH
00	11	8086	3428	1	Intel Corporation QuickPath Interconnect Routing and Protocol Layer Registers Port 1 (rev 10)	IOH
00	14	8086	342e	0	Intel Corporation QuickPath Architecture I/O Hub System Management Registers (rev 10)	IOH
00	14	8086	3422	1	Intel Corporation QuickPath Architecture I/O Hub GPIO and Scratch Pad Registers (rev 10)	IOH
00	14	8086	3423	2	Intel Corporation QuickPath Architecture I/O Hub Control Status and RAS Registers (rev 10)	IOH
00	14	8086	3438	3	Intel Corporation QuickPath Architecture I/O Hub Throttle Registers (rev 10)	IOH
00	16	8086	3430	0	Intel Corporation DMA Engine (rev 10)	IOH
00	16	8086	3431	1	Intel Corporation DMA Engine (rev 10)	IOH
00	16	8086	3432	2	Intel Corporation DMA Engine (rev 10)	IOH
00	16	8086	3433	3	Intel Corporation DMA Engine (rev 10)	IOH
00	16	8086	3429	4	Intel Corporation DMA Engine (rev 10)	IOH
00	16	8086	342a	5	Intel Corporation DMA Engine (rev 10)	IOH
00	16	8086	342b	6	Intel Corporation DMA Engine (rev 10)	IOH
00	16	8086	342c	7	Intel Corporation DMA Engine (rev 10)	IOH
00	1d	8086	3a34	0	Intel Corporation ICH10 USB UHCI Controller #1	ICH
00	1d	8086	3a35	1	Intel Corporation ICH10 USB UHCI Controller #2	ICH
00	1d	8086	3a36	2	Intel Corporation ICH10 USB UHCI Controller #3	ICH

BUS#	DEV#	V. ID	D. ID	Funct. #	Description	PCI Description
00	1d	8086	3a3a	7	Intel Corporation ICH10 USB2 EHCI Controller #1	ICH
00	1e	8086	244e	0	Intel Corporation 82801 PCI Bridge (rev 90)	ICH
00	1f	8086	3a16	0	Intel Corporation ICH10 LPC Interface Controller	ICH
00	1f	8086	3a22	2	Intel Corporation ICH10 6 port SATA AHCI Controller	ICH
00	1f	8086	3a30	3	Intel Corporation ICH10 SMBus Controller	ICH
02	00	8086	10c9	0	Intel Corporation 82576 Gigabit Network Connection	I82576 on Base Interface
02	00	8086	10c9	0	Intel Corporation 82576 Gigabit Network Connection	I82576 on Base Interface
03	00	8086	10d8	0	Intel Corporation 82599 Gigabit Network Connection	I82599 on Fabric Interface
03	00	8086	10d8	1	Intel Corporation 82599 Gigabit Network Connection	I82599 on Fabric Interface
04	00	8086	10c9	0	Intel Corporation 82576 Gigabit Network Connection	I82576 on Management LAN
04	00	8086	10c9	1	Intel Corporation 82576 Gigabit Network Connection	I82576 on Management LAN
06	00			0		RTM
0f	00			0		AMC
18	00			0		Update Channel

A.4 Telco Clock

Clock Circuit Overview

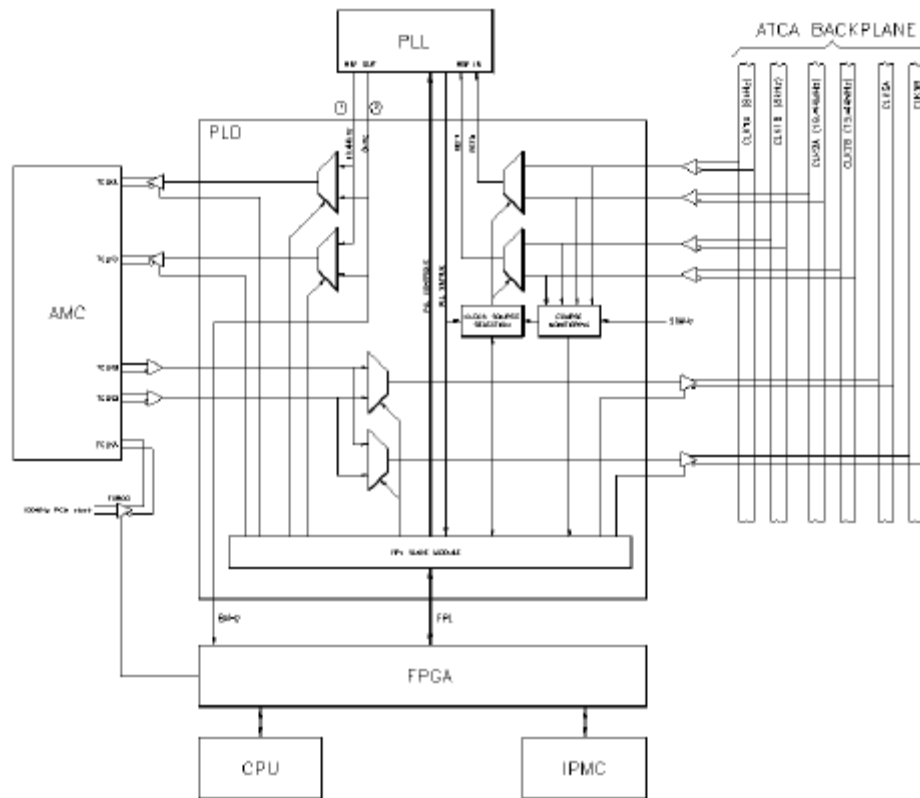

A.4.1 Register Description

A.4.1.1 *Base + 00h TelClock0: Backplane Clock Status, PLL Reference & Interface Selection*

Offset	Action	D7	D6	D6	D4	D3	D2	D1	D0
00h	Read	IFSEL	MAN	SEL_REFA	BP_REF	CLK2B	CLK2A	CLK1B	CLK1A
	Write	IFSEL*	MAN	SEL_REFM	BP_REF	NU	NU	NU	NU
	Reset	0	0	0	0	NA	NA	NA	NA

Name	Description
IFSEL	Interface selection. This bit is always writable from the IPMC side but on the LPC side, the CPU can only read it. 1: IPMC has write control of the interface 0: Main CPU (LPC) has write control of the interface
MAN	0: The PLD chooses automatically the reference used by the DPLL (CLKA or B). 1: Selection of the DPLL reference is manual. Write the selection in bit SEL_REF.
SEL_REFA SEL_REFM	On a read, return the reference automatically selected by the CPLD: 0: REF0 is the reference used by the PLL (i.e. CLKA) 1: REF1 is the reference used by the PLL (i.e. CLKB) When bit MAN=1, the application software can select the reference by writing the desired value in this bit. This bit is not writable when MAN=0. Note that on a read, this bit returns the automatic selection event if MAN=1.
BP_REF	Backplane selection of clock to connect to the PLL. 0: Use backplane CLK1A and CLK1B (8kHz) 1: Use backplane CLK2A and CLK2B (19.44MHz)
CLK1A/B CLK2A/B	Coarse monitoring status. A1 indicate that the corresponding backplane clock is present. A0, that it is absent. Those statuses are valid only if CLK1A/B is 8kHz and CLK2A/B is 19.44MHz. If other frequencies are used, those bits should be ignored.

A.4.1.2

Base + 01h TelClock1: PLL Control & Status

Offset	Action	D7	D6	D6	D4	D3	D2	D1	D0
01h	Read	LOCK	FAIL1	FAIL0	0	TIE_CLR#	MODE	RESET	OOR
	Write	NU	NU	NU	NU	TIE_CLR#	MODE	RESET	OOR
	Reset	NA	NA	NA	NA	1	1	0	0

Name	Description
LOCK	PLL lock status. 1: PLL locked 0: PLL not locked (PLL in holdover or free running)
FAIL1	REF1 (CLK1B or CLK2B according to BP_REF) failed with current OOR setting. Same as FAIL0 but for REF1.
FAIL0	REF0 (CLK1A or CLK2A according to BP_REF) failed with current OOR setting. 1: failed clock. 0: passed clock.
TIE_CLR#	Timing-Interval-Error adjustment. 1: normal mode. 0: adjust phase to match reference.
MODE	PLL operating mode. 1: freerun mode(may be used for tests). 0: normal mode.
RESET	Hardware reset of the PLL. This bit is forced to '1' when the payload power (i.e. PLL power) is turned off. 1: reset 0: normal operation
OOR	OUT-OF-Range selection. Determine what is considered a precision fault by the PLL. 1: 64 - 83ppm. 0: 40 - 52ppm.



Note:

This register needs to be reprogrammed every time the blade is resetted. Those are direct pin control and status. See the ZL30108 datasheet for a detailed explanation of the functionality.

A.4.1.3 Base + 02h TelClock2: AMCs Clock Enables & Frequency Selection

Offset	Action	D7	D6	D6	D4	D3	D2	D1	D0
02h	Read	B2TCF	B2TAF	B2TCEN	B2TAEN	B1TCF	B1TAF	B1TCEN	B1TAEN
	Write	B2TCF	B2TAF	B2TCEN	B2TAEN	B1TCF	B1TAF	B1TCEN	B1TAEN
	Reset	0	0	0*	0*	0	0	0*	0*

Name	Description
B2*	Reserved for AMC-B2 (for board that have two AMCs).
B1TCF	AMC-B1 TCLK Frequency 1: use 8kHz frame pulse from PLL 0: use 19.44MHz from PLL
B1TAF	AMC-B1 TCLKA Frequency 1: use 8kHz frame pulse from PLL 0: use 19.44MHz from PLL
B1TCEN	AMC-B1 TCLKC Enable. This bit is forced to 0 when the AMC is in fault or removed. 1: drive AMC-B1 clock TCLKC 0: don't drive AMC-B1 TCLKC
B1TAEN	AMC-B1 TCLKA Enable. this bit is forced to 0 when the AMC is in fault or removed. 1: drive AMC-B1 clock TCLKA 0: don't drive AMC-B1 TCLKA



Note:

If the clock source of the PLL is 19.44MHz, the phase of this clock is unrelated to any other 8kHz clock in the system.

The AMC has to be present and fully powered for the enable bits to be settable. On a unexpected extraction (user doesn't wait for the blue LED), the hardware automatically clears bits B1TCEN and B1TAEN in case a user would extract and re-insert immediatly the AMC.

A.4.1.4 Base + 03h TelClock3: PLD Configuration & Version

Offset	Action	D7	D6	D6	D4	D3	D2	D1	D0
03h	Read	PLD_CONFIG				PLD_VERSION			
	Write					NA			
	Reset					NA			

Name	Description
CONFIG	Circuit configuration that the PLD expect. For the interface and circuit described in this document, this field is away 0000. If the PLD is abscent or not programmed, this field will return 0000.
VERSION	Code version of the PLD for the above configuration. If the PLD is absent or not programmed, this field will return 0000.

A.4.1.5 Base + 04h TelClock4: Backplane CLK3A/B configuration (optional)

Offset	Action	D7	D6	D6	D4	D3	D2	D1	D0
04h	Read	0	0	0	0	CLK3AMC	CLK3FRQ	CLK3BE	CLK3AE
	Write	NU	NU	NU	NU	CLK3AMC	CLK3FRQ	CLK3BE	CLK3AE
	Reset	NA	NA	NA	NA	0	0	0	0

Name	Description
CLK3AMC	Reserved for selection of the AMC that provides the clock for backplane CLK3A/B. Applicable tot boards with two AMCs. 0: use AMC-B1 1: use AMC-B2
CLK3FRQ	Backplane CLK3A frequency. 0: copy AMC TCKLB to backplane CLK3A/B 1: copy AMC TCLKD to backplane CLK3A/B
CLK3BE	Same as CLK3AE but to CLK3B
CLK3AE	Backplane CLK3A Enable. 0: don't drive this clock 1: drive this clock



Note:

The FPGA will automatically clear bits CLK3BE and CLK3AE when the AMC is removed since the clock source is not valid anymore.

A.4.1.6

Base + 05h TelClock5: Clock Events & Alarm (IPMC only)

Offset	Action	D7	D6	D6	D4	D3	D2	D1	D0
05h	Read	LOCKE	FAIL1E	FAILOE	SELREFE	0	0	0	0
	Write	Clear	Clear	Clear	Clear	NU	NU	NU	NU
	Reset	X*	X*	X*	X*	NA	NA	NA	NA

Name	Description
LACKE	Same as FAIL0 but for the lock status of the PLL. This bit captures the “unlock” state. This would typically be used to generate an alarm.
FAIL1E	Same as FAIL0 but for reference 1.
FAILOE	This bit captures the assertion of a failure on reference 0 on the PLL. This is basically a short failure detection that the IPMC would otherwise miss. Use Telco+1 to read the current state. To Clear this bit, write a 1 in it. The bit will be cleared even if there is still a fault on this clock.
SELREFE	Same as FAIL0 but for the selected reference. This bit goes to one everytime the selected reference changes. This is just to inform the software that a reference change occurred.



Note:

* unpredictable: need to be cleared by IPMC on power up.
 Events and alarms are implemented in the FPGA. The FPGA build them using the raw signals from the first three registers.
 Note that this register is only available on the IPMC side of the interface.

B. Connector Pinouts

B.1 Connectors and Headers Summary

Connector	Description
J2	PostCodes
J5	AMC
J8	Ethernet Port 0
J9	Ethernet Port 1
J10	USB (2x Stacked)
J12	Serial Port, COM1
J20	Synchronisation Clocks, Update Channel
J22	USB Flash Drive
J23	Base Interface & Fabric Interface
J30	RTM
P10	Power & IPMB

B.2 Post Codes (J2)

Signal	Pin
VCC3	1
POST:DATA	2
POST:CLOCK	3
GND	4

B.3 AMC B1 (J5)

Pin	Signal	Pin	Signal	Pin	Signal	Pin	Signal
B1	GND	B43	GND	B86	GND	B129	TxD15-
B2	12V	B44	RxD4+	B87	TxD8-	B130	TxD15+
B3	PS1#	B45	RxD4-	B88	TxD8+	B131	GND
B4	MP_3V3	B46	GND	B89	GND	B132	RxD15-
B5	GA0	B47	TxD4+	B90	RxD8-	B133	RxD15+
B6	RSV	B48	TxD4-	B91	RxD8+	B134	GND
B7	GND	B49	GND	B92	GND	B135	TxD16-
B8	RSV	B50	RxD5+	B93	TxD9-	B136	TxD16+
B9	12V	B51	RxD5-	B94	TxD9+	B137	GND
B10	GND	B52	GND	B95	GND	B138	RxD16-
B11	RxD0+	B53	TxD5+	B96	RxD9-	B139	RxD16+
B12	RxD0-	B54	TxD5-	B97	RxD9+	B140	GND
B13	GND	B55	GND	B98	GND	B141	TxD17-
B14	TxD0+	B56	IPMB-L-SCL	B99	TxD10-	B142	TxD17+
B15	TxD0-	B57	12V	B100	TxD10+	B143	GND
B16	GND	B58	GND	B101	GND	B144	RxD17-
B17	GA1	B59	RxD6+	B102	RxD10-	B145	RxD17+
B18	12V	B60	RxD6-	B103	RxD10+	B146	GND
B19	GND	B61	GND	B104	GND	B147	TxD18-
B20	RxD1+	B62	TxD6+	B105	TxD11-	B148	TxD18+
B21	RxD1-	B63	TxD6-	B106	TxD11+	B149	GND
B22	GND	B64	GND	B107	GND	B150	RxD18-
B23	TxD1+	B65	RxD7+	B108	RxD11-	B151	RxD18+
B24	TxD1-	B66	RxD7-	B109	RxD11+	B152	GND
B25	GND	B67	GND	B110	GND	B153	TxD19-
B26	GA2	B68	TxD7+	B111	TxD12-	B154	TxD19+
B27	12V	B69	TxD7-	B112	TxD12+	B155	GND
B28	GND	B70	GND	B113	GND	B156	RxD19-
B29	RxD2+	B71	IPMB-L_SDA	B114	RxD12-	B157	RxD19+
B30	RxD2-	B72	12V	B115	RxD12+	B158	GND
B31	GND	B73	GND	B116	GND	B159	TxD20-
B32	TxD2+	B74	CLK1+	B117	TxD13-	B160	TxD20+
B33	TxD2-	B75	CLK1-	B118	TxD13+	B161	GND
B34	GND	B76	GND	B119	GND	B162	RxD20-
B35	RxD3+	B77	CLK2+	B120	RxD13-	B163	RxD20+
B36	RxD3-	B78	CLK2-	B121	RxD13+	B164	GND
B37	GND	B79	GND	B122	GND	B165	TCLK (N.C.)
B38	TxD3+	B80	CLK3+	B123	TxD14-	B166	TMS (N.C.)
B39	TxD3-	B81	CLK3-	B124	TxD14+	B167	TRST# (N.C.)

Pin	Signal	Pin	Signal	Pin	Signal	Pin	Signal
B40	GND	B82	GND	B125	GND	B168	TDO (N.C.)
B41	ENABLE#	B83	PS0#(GND)	B126	RxD14-	B169	TDI (N.C.)
B42	12V	B84	12V	B127	RxD14+	B170	GND
		B85	GND	B128	GND		

B.4 Ethernet(J8 & J9)

Signal	Pin	Pin	Signal
BI_DA+	1	5	BI_DC-
BI_DA-	2	6	BI_DB-
BI_DB+	3	7	BI_DD+
BI_DC+	4	8	BI_DD-

B.5 USB Port (J10)

Signal	Pin
VCC	1
DATA-	2
DATA+	3
GND	4

B.6 Serial Port, COM1 (J12)

Signal	Pin	Pin	Signal
RTS	1	5	GND
DTR	2	6	RX#
TX#	3	7	DSR
GND	4	8	CTS

B.7 Synchronisation Clocks, Update Channel (J20)

Pin	ROW A	ROW B	ROW C	ROW D	ROW E	ROW F
1	CLK1A+	CLK1A-	CLK1B+	CLK1B-	CLK2A+	CLK2A-
2	Tx4(UP)+	Tx4(UP)-	Rx4(UP)+	Rx4(UP)-	CLK3A+	CLK3A-
3	Tx2(UP)+	Tx2(UP)-	Rx2(UP)+	Rx2(UP)-	Tx3(UP)+	Tx3(UP)-
4	Tx0(UP)+	Tx0(UP)-	Rx0(UP)+	Rx0(UP)-	Tx1(UP)+	Tx1(UP)-
5	Tx2[15]+(N.C.)	Tx2[15]-(N.C.)	Rx2[15]+(N.C.)	Rx2[15]-(N.C.)	Tx3[15]+(N.C.)	Tx3[15]-(N.C.)
6	Tx0[15]+(N.C.)	Tx0[15]-(N.C.)	Rx0[15]+(N.C.)	Rx0[15]-(N.C.)	Tx1[15]+(N.C.)	Tx1[15]-(N.C.)
7	Tx2[14]+(N.C.)	Tx2[14]-(N.C.)	Rx2[14]+(N.C.)	Rx2[14]-(N.C.)	Tx3[14]+(N.C.)	Tx3[14]-(N.C.)
8	Tx0[14]+(N.C.)	Tx0[14]-(N.C.)	Rx0[14]+(N.C.)	Rx0[14]-(N.C.)	Tx1[14]+(N.C.)	Tx1[14]-(N.C.)
9	Tx2[13]+(N.C.)	Tx2[13]-(N.C.)	Rx2[13]+(N.C.)	Rx2[13]-(N.C.)	Tx3[13]+(N.C.)	Tx3[13]-(N.C.)
10	Tx0[13]+(N.C.)	Tx0[13]-(N.C.)	Rx0[13]+(N.C.)	Rx0[13]-(N.C.)	Tx1[13]+(N.C.)	Tx1[13]-(N.C.)

Pin	ROW G	ROW H	ROW AB	ROW CD	ROW EF	ROW GH
1	CLK2B+	CLK2B-	GND	GND	GND	GND
2	CLK3B+	CLK3B-	GND	GND	GND	GND
3	Rx3(UP)+	Rx3(UP)-	GND	GND	GND	GND
4	Rx1(UP)+	Rx1(UP)-	GND	GND	GND	GND
5	Rx3[15]+(N.C.)	Rx3[15]-(N.C.)	GND	GND	GND	GND
6	Rx1[15]+(N.C.)	Rx1[15]-(N.C.)	GND	GND	GND	GND
7	Rx3[14]+(N.C.)	Rx3[14]-(N.C.)	GND	GND	GND	GND
8	Rx1[14]+(N.C.)	Rx1[14]-(N.C.)	GND	GND	GND	GND
9	Rx3[13]+(N.C.)	Rx3[13]-(N.C.)	GND	GND	GND	GND
10	Rx1[13]+(N.C.)	Rx1[13]-(N.C.)	GND	GND	GND	GND

B.8 USB Flash Drive (J22)

Signal	Pin	Pin	Signal
VCC	1	6	N.C.
N.C.	2	7	GND
USB_DATA-	3	8	N.C.
N.C.	4	9	
USB_DATA+	5	10	RSV

B.9 Base Interface & Fabric Interface (J23)

Pin	ROW A	ROW B	ROW C	ROW D	ROW E	ROW F
1	Tx2[2]+	Tx2[2]-	Rx2[2]+	Rx2[2]-	Tx3[2]+	Tx3[2]-
2	Tx0[2]+	Tx0[2]-	Rx0[2]+	Rx0[2]-	Tx1[2]+	Tx1[2]-
3	Tx2[1]+	Tx2[1]-	Rx2[1]+	Rx2[1]-	Tx3[1]+	Tx3[1]-
4	Tx0[1]+	Tx0[1]-	Rx0[1]+	Rx0[1]-	Tx1[1]+	Tx1[1]-
5	BI_DA1+	BI_DA1-	BI_DB1+	BI_DB1-	BI_DC1+	BI_DC1-
6	BI_DA2+	DI_DA2-	BI_DB2+	BI_DB2-	DI_DC2+	BI_DC2-
7	N.C.	N.C.	N.C.	N.C.	N.C.	N.C.
8	N.C.	N.C.	N.C.	N.C.	N.C.	N.C.
9	N.C.	N.C.	N.C.	N.C.	N.C.	N.C.
10	N.C.	N.C.	N.C.	N.C.	N.C.	N.C.

Pin	ROW G	ROW H	ROW AB	ROW CD	ROW EF	ROW GH
1	Rx3[2]+	Rx3[2]-	GND	GND	GND	GND
2	Rx1[2]+	Rx1[2]-	GND	GND	GND	GND
3	Rx3[1]+	Rx3[1]-	GND	GND	GND	GND
4	Rx1[1]+	Rx1[1]-	GND	GND	GND	GND
5	BI_DD1+	BI_DD1-	GND	GND	GND	GND
6	BI_DD2+	DI_DD2-	GND	GND	GND	GND
7	N.C.	N.C.	GND	GND	GND	GND
8	N.C.	N.C.	GND	GND	GND	GND
9	N.C.	N.C.	GND	GND	GND	GND
10	N.C.	N.C.	GND	GND	GND	GND

B.10 RTM Connector (J30)

Pin	ROW A	ROW B	ROW C	ROW D	ROW E	ROW F
1	V_12V_1	V_12V_5	V_12V_2	V_3V2_SUS	FPGA_IO_3	RTM_PRSNT#
2	V_12V_3	V_12V_6	V_12V_4	NC_D2	IPMC_SCL	IPMC_SDA
3	SP_TX	SP_RX	JTAG_TD1	JTAG_TD0	JTAG_TMS	JTAG_TCK
4	USB1_D+	USB1_D-	INT_0	INT_1	RTML_TX	RTML_RX
5	SP_RTS#	SP_CTS#	MD2#	RSVD_D5	CLK_PE+	CLK_PE-
6	SATA_TX+	SATA_TX-	SATA_RX+	SATA_RX-	SFP1_SCL	SFP1_SDA
7	SAS_0_TX+	SAS_0_TX-	SAS_0_RX+	SAS_0_RX-	SAS_1_TX-	SAS_1_TX+
8	GBE_TX1+	GBE_TX1-	GBE_RX1+	GBE_RX1-	GBE_TX2+	GBE_TX2-
9	PE6_TX-	PE6_TX+	PE7_RX-	PE7_RX+	PE5_TX+	PE5_TX-
10	PE4_TX-	PE4_TX+	PE5_RX+	PE5_RX-	PE7_TX+	PE7_TX-

Pin	ROW G	ROW H	ROW AB	ROW CD	ROW EF	ROW GH
1	FPGA_IO_1	RTM_EN#	GND	GND	GND	GND
2	USB0_D+	USB0_D-	GND	GND	GND	GND
3	JTAG_TRST	FPGA_IO_2	GND	GND	GND	GND
4	RTML_CLK	PROG	GND	GND	GND	GND
5	RSVD_G5	JTAG_SEL	GND	GND	GND	GND
6	SFP0_SCL	SFP0_SDA	GND	GND	GND	GND
7	SAS_1_RX+	SAS_1_RX-	GND	GND	GND	GND
8	GBE_RX2+	GBE_RX2-	GND	GND	GND	GND
9	PE6_RX+	PE6_RX-	GND	GND	GND	GND
10	PE4_RX-	PE4_RX+	GND	GND	GND	GND

B.11 Power (P10)

Signal	Pin	Pin	Signal
N.P.	1	2	N.P.
N.P.	3	4	N.P.
HA0	5	6	HA1
HA2	7	8	HA3
HA4	9	10	HA5
HA6	11	12	HA7/P
SCL_A	13	14	SDA_A
SCL_B	15	16	SDA_B
MT1_TIP(N.C.)	17	18	MT2_TIP(N.C.)
RING_A(N.C.)	19	20	RING_B(N.C.)
MT1_RING(N.C.)	21	22	MT2_RING(N.C.)
RRTN_A(N.C.)	23	24	RRTN_B(N.C.)
SHELF_GND	25	26	LOGIC_GND
ENABLE_B	27	28	VRTN_A
VRTN_B	29	30	EARLY_A
EARLY_B	31	32	ENABLE_A
-48V_A	33	34	-48V_B

C. BIOS Setup Error Codes

C.1 Bootblock Initialization Code Checkpoints

The Bootblock initialization code sets up the chipset, memory and other components before system memory is available. The following table describes the type of checkpoints that may occur during the bootblock initialization portion of the BIOS:

Checkpoint	Description
Before D1	Early chipset initialization is done. Early super I/O initialization is done including RTC and keyboard controller. NMI is disabled.
D1	Perform keyboard controller BAT test. Check if waking up from power management suspend state. Save power-on CPUID value in scratch CMOS.
D0	Go to flat mode with 4GB limit and GA20 enabled. Verify the bootblock checksum.
D2	Disable CACHE before memory detection. Execute full memory sizing module. Verify that flat mode is enabled.
D3	If memory sizing module not executed, start memory refresh and do memory sizing in Bootblock code. Do additional chipset initialization. Re-enable CACHE. Verify that flat mode is enabled.
D4	Test base 512KB memory. Adjust policies and cache first 8MB. Set stack.
D5	Bootblock code is copied from ROM to lower system memory and control is given to it. BIOS now executes out of RAM.
D6	Both key sequence and OEM specific method is checked to determine if BIOS recovery is forced. Main BIOS checksum is tested. If BIOS recovery is necessary, control flows to checkpoint E0. See Bootblock Recovery Code Checkpoints section of document for more information.
D7	Restore CPUID value back into register. The Bootblock-Runtime interface module is moved to system memory and control is given to it. Determine whether to execute serial flash.
D8	The Runtime module is uncompressed into memory. CPUID information is stored in memory.
D9	Store the Uncompressed pointer for future use in PMM. Copying Main BIOS into memory. Leaves all RAM below 1MB Read-Write including E000 and F000 shadow areas but closing SMRAM.
DA	Restore CPUID value back into register. Give control to BIOS POST (ExecutePOSTKernel). See POST Code Checkpoints section of document for more information.
E1-E8	
EC-EE	OEM memory detection/configuration error. This range is reserved for chipset vendors & system manufacturers. The error associated with this value may be different from one platform to the next. Refer to memory initialization ERROR CODE D.5

C.2 POST Code Checkpoints

The POST code checkpoints are the largest set of checkpoints during the BIOS pre-boot process. The following table describes the type of checkpoints that may occur during the POST portion of the BIOS:

Checkpoint	Description
03	Disable NMI, Parity, video for EGA, and DMA controllers. Initialize BIOS, POST, Runtime data area. Also initialize BIOS modules on POST entry and GPNV area. Initialize CMOS as mentioned in the Kernel Variable "wCMOSFlags."
04	Check CMOS diagnostic byte to determine if battery power is OK and CMOS checksum is OK. Verify CMOS checksum manually by reading storage area. If the CMOS checksum is bad, update CMOS with power-on default values and clear passwords. Initialize status register A. Initializes data variables that are based on CMOS setup questions. Initializes both the 8259 compatible PICs in the system
05	Initializes the interrupt controlling hardware (generally PIC) and interrupt vector table.
06	Do R/W test to CH-2 count reg. Initialize CH-0 as system timer. Install the POSTINT1Ch handler. Enable IRQ-0 in PIC for system timer interrupt. Traps INT1Ch vector to "POSTINT1ChHandlerBlock."
08	Initializes the CPU. The BAT test is being done on KBC. Program the keyboard controller command byte is being done after Auto detection of KB/MS using AMI KB-5.
C0	Early CPU Init Start -- Disable Cache - Init Local APIC
C1	Set up boot strap processor Information
C2	Set up boot strap processor for POST
C5	Enumerate and set up application processors
C6	Re-enable cache for boot strap processor
C7	Early CPU Init Exit
0A	Initializes the 8042 compatible Key Board Controller.
0B	Detects the presence of PS/2 mouse.
0C	Detects the presence of Keyboard in KBC port.
0E	Testing and initialization of different Input Devices. Also, update the Kernel Variables. Traps the INT09h vector, so that the POST INT09h handler gets control for IRQ1. Uncompress all available language, BIOS logo, and Silent logo modules.
13	Early POST initialization of chipset registers.
24	Uncompress and initialize any platform specific BIOS modules.
30	Initialize System Management Interrupt.
2A	Initializes different devices through DIM. See DIM Code Checkpoints section of document for more information.
2C	Initializes different devices. Detects and initializes the video adapter installed in the system that have optional ROMs.
2E	Initializes all the output devices.
31	Allocate memory for ADM module and uncompress it. Give control to ADM module for initialization. Initialize language and font modules for ADM. Activate ADM module.
33	Initializes the silent boot module. Set the window for displaying text information.
37	Displaying sign-on message, CPU information, setup key message, and any OEM specific information.
38	Initializes different devices through DIM. See DIM Code Checkpoints section of document for more information.
39	Initializes DMAC-1 & DMAC-2.

Checkpoint	Description
3A	Initialize RTC date/time.
3B	Test for total memory installed in the system. Also, Check for DEL or ESC keys to limit memory test. Display total memory in the system.
3C	Mid POST initialization of chipset registers.
40	Detect different devices (Parallel ports, serial ports, and coprocessor in CPU, ... etc.) successfully installed in the system and update the BDA, EBDA...etc.
50	Programming the memory hole or any kind of implementation that needs an adjustment in system RAM size if needed.
52	Updates CMOS memory size from memory found in memory test. Allocates memory for Extended BIOS Data Area from base memory.
60	Initializes NUM-LOCK status and programs the KBD typematic rate.
75	Initialize Int-13 and prepare for IPL detection.
78	Initializes IPL devices controlled by BIOS and option ROMs.
7A	Initializes remaining option ROMs.
7C	Generate and write contents of ESCD in NVRam.
84	Log errors encountered during POST.
85	Display errors to the user and gets the user response for error.
87	Execute BIOS setup if needed / requested.
8C	Late POST initialization of chipset registers.
8D	Build ACPI tables (if ACPI is supported)
8E	Program the peripheral parameters. Enable/Disable NMI as selected
90	Late POST initialization of system management interrupt.
A0	Check boot password if installed.
A1	Clean-up work needed before booting to OS.
A2	Takes care of runtime image preparation for different BIOS modules. Fill the free area in F000h segment with 0FFh. Initializes the Microsoft IRQ Routing Table. Prepares the runtime language module. Disables the system configuration display if needed.
A4	Initialize runtime language module.
A7	Displays the system configuration screen if enabled. Initialize the CPU's before boot, which includes the programming of the MTRR's.
A8	Prepare CPU for OS boot including final MTRR values.
A9	Wait for user input at config display if needed.
AA	Uninstall POST INT1Ch vector and INT09h vector. Deinitializes the ADM module.
AB	Prepare BBS for Int 19 boot.
AC	End of POST initialization of chipset registers.
B1	Save system context for ACPI.
00	Passes control to OS Loader (typically INT19h).
61-70	OEM POST Error. This range is reserved for chipset vendors & system manufacturers. The error associated with this value may be different from one platform to the next.
DD-DE	OEM PCI init debug POST code during DIMM init, See DIM Code Checkpoints section of document for more information.

C.3 DIM Code Checkpoints

The Device Initialization Manager (DIM) gets control at various times during BIOS POST to initialize different system busses. The following table describes the main checkpoints where the DIM module is accessed:

Checkpoint	Description
2A	Initialize different buses and perform the following functions: Reset, Detect, and Disable (function 0); Static Device Initialization (function 1); Boot Output Device Initialization (function 2). Function 0 disables all device nodes, PCI devices, and PnP ISA cards. It also assigns PCI bus numbers. Function 1 initializes all static devices that include manual configured onboard peripherals, memory and I/O decode windows in PCI-PCI bridges, and noncompliant PCI devices. Static resources are also reserved. Function 2 searches for and initializes any PnP, PCI, or AGP video devices.
38	Initialize different buses and perform the following functions: Boot Input Device Initialization (function 3); IPL Device Initialization (function 4); General Device Initialization (function 5). Function 3 searches for and configures PCI input devices and detects if system has standard keyboard controller. Function 4 searches for and configures all PnP and PCI boot devices. Function 5 CONFIGURES all onboard peripherals that are set to an automatic configuration and configures all remaining PnP and PCI devices.
DD-DE	OEM PCI init debug POST code during DIMM init. DEh during BUS number assignment and DDh during ressource allocation, Hight byte is the BUS number.

While control is in the different functions, additional checkpoints are output to port 80h as a word value to identify the routines under execution. The low byte value indicates the main POST Code Checkpoint. The high byte is divided into two nibbles and contains two fields. The details of the high byte of these checkpoints are as follows:

HIGH BYTE XY

The upper nibble 'X' indicates the function number that is being executed. 'X' can be from 0 to 7.

0 = func#0, disable all devices on the BUS concerned.

1 = func#1, static devices initialization on the BUS concerned.

2 = func#2, output device initialization on the BUS concerned.

3 = func#3, input device initialization on the BUS concerned.

4 = func#4, IPL device initialization on the BUS concerned.

5 = func#5, general device initialization on the BUS concerned.

6 = func#6, error reporting for the BUS concerned.

7 = func#7, add-on ROM initialization for all BUSes.

8 = func#8, BBS ROM initialization for all BUSes.

The lower nibble 'Y' indicates the BUS on which the different routines are being executed. 'Y' can be from 0 to 5.

0 = Generic DIM (Device Initialization Manager).

1 = On-board System devices.

2 = ISA devices.

3 = EISA devices.

4 = ISA PnP devices.

5 = PCI devices.

C.4 Memory Initialization ERROR Code

Checkpoint	Description
E8	Memory Error - No memory installed.
EA	Memory Error - DDR3 Initialisation
EB	Memory Error - Memory test
ED	Memory Error - RDIMMs and UDIMMs are mixed
EE	Memory Error - Invalid Memory Population
EF	Memory Error - Memory structure problem

D. Software Update

To update the board software, it is recommended to use the Kontron update CD. A version of this CD can be found on the CD/DVD provided with your board or on the Kontron's [FTP](#) site. Updating your board with this Update CD will have a payload impact on your board. To update your board from the update CD, boot from the CD and follow the instructions provided in the AT8050 - Update CD User guide provided with the CD image file.

A remote update procedure is also available using the HPM files. This procedure has no payload impact. The instructions on how to use it are provided with the HPM package.

The latest versions of the Update CD and HPM files are available from the Kontron's [FTP](#) site(cbu.kontron.ca).

E. Getting Help

If, at any time, you encounter difficulties with your application or with any of our products, or if you simply need guidance on system setups and capabilities, contact our Technical Support at:

North America	EMEA
Tel.: +1 888 294 4558	Tel.: +800-KONTRONAG
Fax: +1 858 677 0898	Fax: +49 821 4086 888

If you have any questions about Kontron, our products, or services, visit our Web site at: www.kontron.com

You also can contact us by E-mail at:

North America: support@us.kontron.com

EMEA: support@kontron.com

Or at the following address:

North America	EMEA
Kontron America, Inc.	Kontron Europe GmbH
14118 Stowe Drive	Lise-Meitner-Str. 3-5
Poway, CA 92064-7147	86156 Augsburg
USA	Germany

E.1 Returning Defective Merchandise

Before returning any merchandise please do one of the following:

- Call

1 Call our Technical Support department in North America at +1 888 294 4558 and in EMEA at +800-KONTRONAG. Make sure you have the following on hand: our Invoice #, your Purchase Order #, and the Serial Number of the defective unit.

2 Provide the serial number found on the back of the unit and explain the nature of your problem to a service technician.

3The technician will instruct you on the return procedure if the problem cannot be solved over the telephone.

4Make sure you receive an RMA # from our Technical Support before returning any merchandise.

- E-mail

1Send us an e-mail at: support@us.kontron.com in North America and at: support@kontron.com in EMEA. In the e-mail, you must include your name, your company name, your address, your city, your postal/zip code, your phone number, and your e-mail. You must also include the serial number of the defective product and a description of the problem.

E.2 When Returning a Unit

- In the box, you must include the name and telephone number of a contact person, in case further explanations are required. Where applicable, always include all duty papers and invoice(s) associated with the item(s) in question.
- Ensure that the unit is properly packed. Pack it in a rigid cardboard box.
- Clearly write or mark the RMA number on the outside of the package you are returning.
- Ship prepaid. We take care of insuring incoming units.

North America	EMEA
Kontron America, Inc.	Kontron Europe GmbH
14118 Stowe Drive	Lise-Meitner-Str. 3-5
Poway, CA 92064-7147	86156 Augsburg
USA	Germany

F. Glossary

Acronyms	Descriptions
ACPI	Advanced Configuration & Power Interface
AdvancedMC	(Same as AMC). Advanced Mezzanine Card.
AMC	(Same as AdvancedMC). Advanced Mezzanine Card.
AMC.0	Advanced Mezzanine Card Base Specification.
AMC.1	PCI Express and Advanced Switching on AdvancedMC. A subsidiary specification to the Advanced Mezzanine Card Base Specification (AMC.0).
AMC.2	Ethernet Advanced Mezzanine Card Specification. A subsidiary specification to the Advanced Mezzanine Card Base Specification (AMC.0).
AMC.3	Advanced Mezzanine Card Specification for Storage. A subsidiary specification to the Advanced Mezzanine Card Base Specification (AMC.0).
ANSI	American National Standards Institute
API	Application Programming Interface
APIC	Advanced Programmable Interrupt Controller
ASCII	American Standard Code for Information Interchange. ASCII codes represent text in computers, communications equipment, and other devices that work with text.
ATA	Advanced Technology Attachment
ATAPI	Advanced Technology Attachment Packet Interface
ATCA	Advanced Telecommunications Computing Architecture
BBS	BIOS Boot Specification
BI	Base Interface. Backplane connectivity defined by the ATCA.
BIOS	Basic Input/Output System
BMC	Base Management Controller
CD	Compact Disk
CDROM	(Same as CD-ROM). Compact Disk Read-Only Memory.
CD-ROM	(Same as CDROM). Compact Disk Read-Only Memory.
CFM	Cubic Foot per Minute
CLI	Command-Line Interface
CLK1	AdvancedTCA based resource Synch clock group 1
CLK1A	AdvancedTCA based resource Synch clock group 1, bus A
CLK1B	AdvancedTCA based resource Synch clock group 1, bus A
CLK2	AdvancedTCA based resource Synch clock group 2
CLK2A	AdvancedTCA based resource Synch clock group 2, bus A
CLK2B	AdvancedTCA based resource Synch clock group 2, bus B
CLK3	AdvancedTCA based resource Synch clock group 3
CLK3A	AdvancedTCA based resource Synch clock group 3, bus A
CLK3B	AdvancedTCA based resource Synch clock group 3, bus B
CMOS	Complementary Metal Oxide Semiconductor. Also refers to the small amount of battery (or capacitor) powered CMOS memory to hold the date, time, and system setup parameters.
CPLD	Complex Programmable Logic Device
CP-TA	Communications Platforms Trade Association
CPU	Central Processing Unit. This sometimes refers to a whole blade, not just a processor component.

Acronyms	Descriptions
CTS	Clear To Send
DDR3	DDR3 SDRAM or Double-Data-Rate three (3) Synchronous Dynamic Random Access Memory.
DHCP	Dynamic Host Configuration Protocol
DIMM	Dual In-line Memory Module
DMA	Direct Memory Access
DMI	Desktop Management Interface
DTC	Data Transfer Controller
DTR	Data Terminal Ready
DTS	Digital Thermal Sensor in IA32 processors.
DVD	Digital Video Disk
ECC	Error Checking and Correction
EMI	ElectroMagnetic Interference
ETH	Same as Ethernet.
FC	Fibre Channel
FCC	Federal Communications Commission
FI	Fabric Interface. Backplane connectivity defined by the ATCA.
FIFO	First In First Out
FPGA	Field-Programmable Gate Array
FRU	Field Replaceable Unit. Any entity that can be replaced by a user in the field. Not all FRUs are hot swappable.
FWH	FirmWare Hub. Boot flash connected to the LPC bus containing BIOS FW.
Gb	Gigabit
GB	(Same as GByte) GigaByte.
GByte	(Same as GB) GigaByte.
GbE	Gigabit Ethernet
GHz	GigaHertz
GND	GrouND
HDD	Hard Disc Drive
HPM	PICMG Hardware Platform Management specification family
HPM.1	Hardware Platform Management IPM Controller Firmware Upgrade Specification
HW	HardWare
I2C	Inter Integrated Circuit bus
ICH	I/O Controller Hub
ICT	In-Circuit Test
ID	IDentification
IEEE	Institute of Electrical and Electronics Engineers
IMVP-6	Intel Mobile Voltage Positioning. The Intel Mobile Voltage Positioning specification for the Intel® Core™ Duo Processor. It is a DC-DC converter module that supplies the required voltage and current to a single processor.
IO	(Same as I/O). Input Output
IOH	I/O Hub
IOL	IPMI-Over-LAN
IP	Internet Protocol

Acronyms	Descriptions
IPM	Intelligent Platform Management
IPMB	Intelligent Platform Management Bus
IPMB-0	Intelligent Platform Management Bus Channel 0, the logical aggregation of IPMB-A and IPMB-B.
IPMB-A	Intelligent Platform Management Bus A
IPMB-B	Intelligent Platform Management Bus B
IPMB-L	Intelligent Platform Management Bus Local
IPMC	Intelligent Platform Management Controller
IPMI	Intelligent Platform Management Interface
IPMIFWU	Intelligent Platform Management Interface FirmWare Update
IPv6	Internet Protocol version 6
IRQ	Interrupt ReQuest
JTAG	Joint Test Action Group
KHz	KiloHertz
LAN	Local Area Network
LED	Light-Emitting Diode
LFM	Low Frequency Mode. The lowest operating speed for the processor.
LPC	Low Pin Count port
MAC	Media Access Controller address of a computer networking device.
MB	MegaByte
MCH	Memory Controller Hub
MHz	MegaHertz
MMC	Module Management Controller. MMCs are linked to the IPMC.
NC	Not Connected
OOS	Out Of Service
OS	Operating System
PHY	PHYSical layer. Generic electronics term referring to a special electronic integrated circuit or functional block of a circuit that takes care of encoding and decoding between a pure digital domain (on-off) and a modulation in the analog domain.
PICMG	PCI Industrial Computer Manufacturers Group
PICMG®	PCI Industrial Computer Manufacturers Group
POST	Power-On Self-Test
prAMC	Processor AMC
RAID	Redundant Array of Independent Disks / Redundant Array of Inexpensive Disks.
RAM	Random Access Memory
RHEL	Red Hat Enterprise Linux
RoHS	Restriction of the Use of Certain Hazardous Substances
RS-232	(Same as RS232). Recommended Standard 232.
RS232	(Same as RS-232). Recommended Standard 232.
RTC	Real Time Clock
RTM	Rear Transition Module
RTM-Link	Rear Transition Module Link. Kontron 3-wire protocol.
RTS	Request To Send

Acronyms	Descriptions
SAS	Serial Attached SCSI
SATA	Serial ATA
SEL	System Event Log
SFP	Small Form-factor Pluggable
ShMC	Shelf Management Controller
SMB	(Same as SMBus/SMBUS). System Management Bus.
SMBIOS	System Management BIOS
SMBUS	(Same as SMB/SMBus). System Management Bus.
SMBus	(Same as SMB/SMBUS). System Management Bus.
SOL	Serial Over LAN
SPI	Serial Peripheral Interface
SpeedStep	(Same as EIST). Enhanced Intel SpeedStep Technology.
SSE2	Streaming SIMD Extension 2. SIMD is "Single Instruction, Multiple Data".
SSE3	Streaming SIMD Extension 3. SIMD is "Single Instruction, Multiple Data".
SSH	Secure SHell. A network protocol that allows data to be exchanged over a secure channel between two computers.
TCLKA	Telecom CLoCk A. AMC Clock Interface.
TCLKB	Telecom CLoCk B. AMC Clock Interface.
TCLKC	Telecom CLoCk C. AMC Clock Interface.
TCLKD	Telecom CLoCk D. AMC Clock Interface.
TX	Transmit
TXD	Transmit
UART	Universal Asynchronous Receiver Transmitter
USB	Universal Serial Bus
VCC	Power supply
VLAN	Virtual Local Area Network
XAUI	X (meaning ten) Attachment Unit Interface. A standard for connecting 10 Gigabit Ethernet (10GbE) ports.