

# » Kontron User's Guide «

**Advanced TCA®**

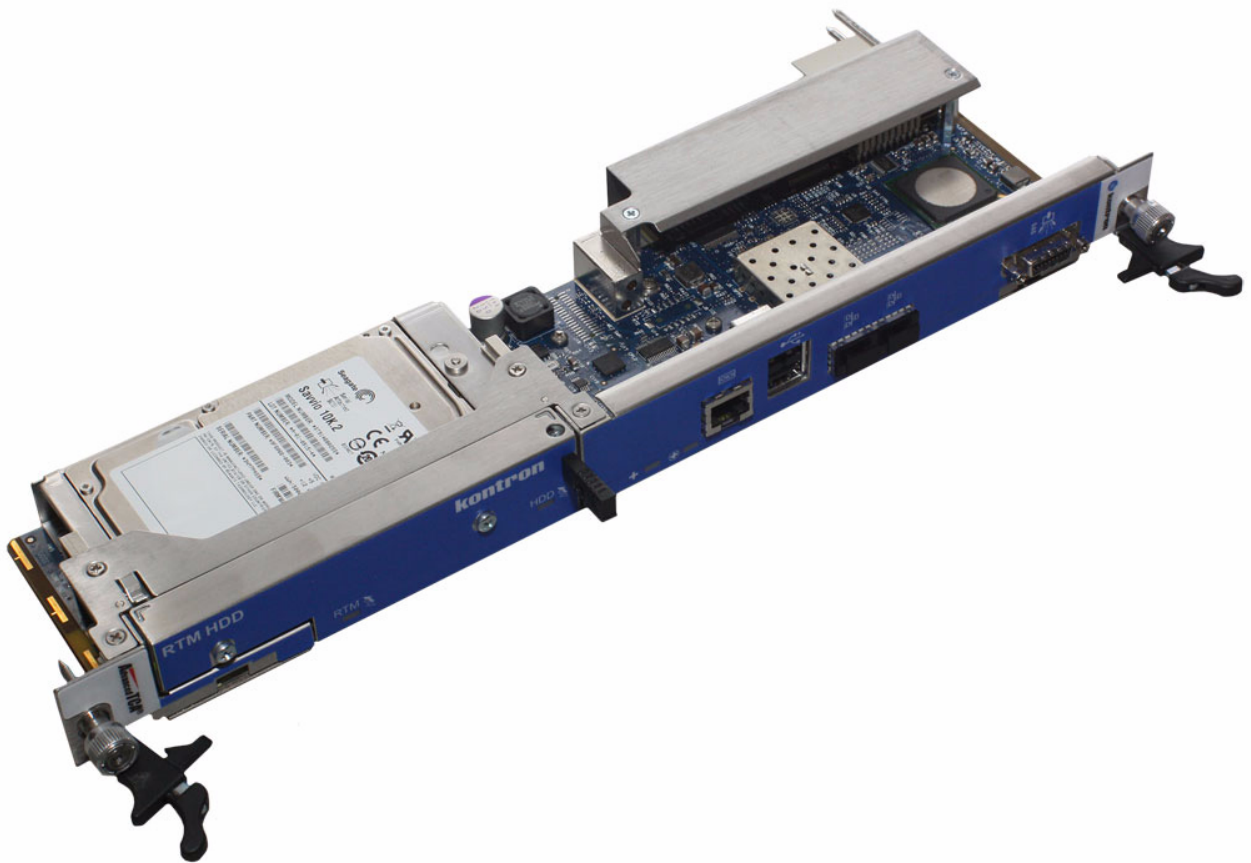

## RTM8050

Document Revision 1.2  
November 2009

# Revision History

Rev. Index	Brief Description of Changes	Date of Issue
1.0	First Release	April 2009
1.0.1	Added IPMB-L Address 0xA6	August 2009
1.1	Second Release	September 2009
1.2	Third Release	November 2009

## Customer Service

### Contact Information:

#### **Kontron Canada, Inc.**

4555 Ambroise-Lafortune  
Boisbriand, Québec, Canada  
J7H 0A4  
Tel: (450) 437-5682  
(800) 354-4223  
Fax: (450) 437-8053  
E-mail: [support@ca.kontron.com](mailto:support@ca.kontron.com)

#### **Kontron Modular Computer GMBH**

Sudetenstrasse 7  
87600 Kaufbeuren  
Germany  
+49 (0) 8341 803 333  
  
+49 (0) 8341 803 339  
[support-kom@kontron.com](mailto:support-kom@kontron.com)

Visit our site at: [www.kontron.com](http://www.kontron.com)

© 2009 Kontron, an International Corporation. All rights reserved.

The information in this user's guide is provided for reference only. Kontron does not assume any liability arising out of the application or use of the information or products described herein. This user's guide may contain or reference information and products protected by copyrights or patents and does not convey any license under the patent rights of Kontron, nor the rights of others.

Kontron is a registered trademark of Kontron. All trademarks, registered trademarks, and trade names used in this user's guide are the property of their respective owners. All rights reserved. Printed in Canada. This user's guide contains information proprietary to Kontron. Customers may reprint and use this user's guide in other publications. Customers may alter this user's guide and publish it only after they remove the Kontron name, cover, and logo.

Kontron reserves the right to make changes without notice in product or component design as warranted by evolution in user needs or progress in engineering or manufacturing technology. Changes that affect the operation of the unit will be documented in the next revision of this user's guide.

# Table of Contents

<i>Safety Instructions</i> .....	<i>vi</i>
Before You Begin .....	vi
Preventing Electrostatic Discharge .....	vii
<i>Preface</i> .....	<i>viii</i>
How to Use This Guide .....	viii
Customer Comments .....	ix
Advisory Conventions .....	ix
Unpacking .....	x
Powering Up the System .....	x
Adapter Cables .....	x
Storing Boards .....	x
Regulatory Compliance Statements .....	xi
Limited Warranty .....	xii
<b>1. Product Description</b> .....	<b>1</b>
1.1 Product Overview .....	1
1.2 What's Included .....	1
1.3 Board Specifications .....	1
1.4 Compliance .....	2
1.5 Hot-Swap Capability .....	3
1.6 Interfacing with the Environment .....	3
1.6.1 RTM (rear transition module) .....	3
<b>2. Board Features</b> .....	<b>5</b>
2.1 Block Diagram .....	5
2.2 USB 2.0 Interface .....	6
2.3 SAS Onboard Controller .....	6
2.4 HD Mezzanine Hot-Swap Option .....	7
2.5 Serial Port .....	7
2.6 SFP .....	7
2.7 MMC Boot Block .....	7

<b>2.8</b>	<b>Hardware Management Overview</b> .....	<b>8</b>
2.8.1	Sensor Data Record (SDR).....	8
2.8.2	Hardware Sensors .....	9
2.8.3	Field Replaceable Unit (FRU) Information .....	10
2.8.4	MMC Firmware Code .....	11
2.8.5	MMC Firmware Upgrade Procedure .....	12
2.8.6	Boot Block Upgrade Procedure .....	12
<b>2.9</b>	<b>Face Plate Indicators</b> .....	<b>13</b>
2.9.1	Hot Swap LED (LED0) .....	13
2.9.2	Out Of Service (LED1) .....	13
2.9.3	Healthy LED (LED2).....	13
2.9.4	RTMDISK Hot Swap LED.....	13
<b>3.</b>	<b>Hot Swap and Installation</b> .....	<b>14</b>
<b>3.1</b>	<b>RTM Hot Swap and Installation</b> .....	<b>14</b>
3.1.1	Installing the RTM in the chassis.....	14
3.1.2	Removing the RTM from the chassis .....	14
<b>3.2</b>	<b>RTMHDD Hot Swap and Installation</b> .....	<b>15</b>
3.2.1	Installing the Hot Swap RTMHDD .....	15
3.2.2	Removing the Hot Swap RTMHDD .....	15
<b>A.</b>	<b>Connector Pinouts</b> .....	<b>A-1</b>
<b>A.1</b>	<b>Connectors and Headers Summary</b> .....	<b>A-1</b>
<b>A.2</b>	<b>AdvancedTCA I/O RTM Connector (P30)</b> .....	<b>A-2</b>
<b>A.3</b>	<b>SAS Faceplate Connector (J1)</b> .....	<b>A-3</b>
<b>A.4</b>	<b>SFP Channel (J4 &amp; J5)</b> .....	<b>A-3</b>
<b>A.5</b>	<b>Dual USB Port (J7)</b> .....	<b>A-4</b>
<b>A.6</b>	<b>Serial Port(J9)</b> .....	<b>A-4</b>
<b>A.7</b>	<b>Hot Swap Hard Disk Module(J13)</b> .....	<b>A-4</b>
<b>B.</b>	<b>Software Update</b> .....	<b>B-1</b>
<b>B.1</b>	<b>MMC Firmware Update Procedure</b> .....	<b>B-1</b>
<b>C.</b>	<b>Getting Help</b> .....	<b>C-1</b>
<b>C.1</b>	<b>Returning Defective Merchandise</b> .....	<b>C-1</b>
<b>C.2</b>	<b>When Returning a Unit</b> .....	<b>C-2</b>
<b>D.</b>	<b>Glossary</b> .....	<b>D-1</b>

# List of Figures

Figure 2-1: Block Diagram .....5

---

# List of Tables

Table 1-1 Board Specifications . . . . .	1
Table 2-1 USB Connector Pinout . . . . .	6
Table 2-2 Serial Port Connector Pinout . . . . .	7
Table 2-3 IPMI Hardware Sensors . . . . .	9
Table 2-4 Board Information Area . . . . .	10
Table 2-5 Product Information Area . . . . .	10
Table 2-6 Type 16 Module Current Requirements Records . . . . .	11
Table 2-7 Hot-Swap LED Description . . . . .	12

# Safety Instructions

## Before You Begin

Before handling the board, read the instructions and safety guidelines on the following pages to prevent damage to the product and to ensure your own personal safety. Refer to the "Advisories" section in the Preface for advisory conventions used in this user's guide, including the distinction between Warnings, Cautions, Important Notes, and Notes.

- Always use caution when handling/operating the computer. Only qualified, experienced, authorized electronics service personnel should access the interior of the computer. The power supplies produce high voltages and energy hazards, which can cause bodily harm.
- Use extreme caution when installing or removing components. Refer to the installation instructions in this user's guide for precautions and procedures. If you have any questions, please contact Kontron Technical Support



---

**WARNING**

High voltages are present inside the chassis when the unit's power cord is plugged into an electrical outlet. Turn off system power, turn off the power supply, and then disconnect the power cord from its source before removing the chassis cover. Turning off the system power switch does not remove power to components.

---



# Preventing Electrostatic Discharge

Static electricity can harm system boards. Perform service at an ESD workstation and follow proper ESD procedure to reduce the risk of damage to components. Kontron strongly encourages you to follow proper ESD procedure, which can include wrist straps and smocks, when servicing equipment.

Take the following steps to prevent damage from electrostatic discharge (ESD):

- When unpacking a static-sensitive component from its shipping carton, do not remove the component's antistatic packing material until you are ready to install the component in a computer. Just before unwrapping the antistatic packaging, be sure you are at an ESD workstation or grounded. This will discharge any static electricity that may have built up in your body.
- When transporting a sensitive component, first place it in an antistatic container or packaging.
- Handle all sensitive components at an ESD workstation. If possible, use antistatic floor pads and workbench pads.
- Handle components and boards with care. Don't touch the components or contacts on a board. Hold a board by its edges or by its metal mounting bracket.
- Do not handle or store system boards near strong electrostatic, electromagnetic, magnetic, or radioactive fields.
- When you want to remove the protective foil (if present), make sure you are properly grounded and that you touch a metallic part of the board.



## CAUTION

Removing the protective foil from the top and bottom cover might create static. When you remove those protections, make sure you follow the proper ESD procedure.





# Preface

## How to Use This Guide

This user's guide is designed to be used as step-by-step instructions for installation, and as a reference for operation, troubleshooting, and upgrades.

For the circuits, descriptions and tables indicated, Kontron assumes no responsibility as far as patents or other rights of third parties are concerned.

The following is a summary of chapter contents:











- Chapter 1, Product Description
- Chapter 2, Board Features
- Chapter 3, Installing the board
- Appendix A, Connector Pinout
- Appendix B, Software Update
- Appendix C, Getting Help
- Appendix D, Glossary

## Customer Comments

If you have any difficulties using this user's guide, discover an error, or just want to provide some feedback, please send a message to: [Tech.Writer@ca.kontron.com](mailto:Tech.Writer@ca.kontron.com). Detail any errors you find. We will correct the errors or problems as soon as possible and post the revised user's guide on our Web site. Thank you.

## Advisory Conventions

Seven types of advisories are used throughout the user guides to provide helpful information or to alert you to the potential for hardware damage or personal injury. They are Note, Signal Paths, Jumpers Settings, BIOS Settings, Software Usage, Cautions, and Warnings. The following is an example of each type of advisory. Use caution when servicing electrical components.

	<b>Note:</b> Indicate information that is important for you to know.	
	<b>Signal Path:</b> Indicate the places where you can find the signal on the board.	
	<b>Jumper Settings:</b> Indicate the jumpers that are related to this sections.	
	<b>BIOS Settings:</b> Indicate where you can set this option in the BIOS.	
	<b>Software Usage:</b> Indicates how you can access this feature through software.	
	<b>CAUTION</b>	
	<b>WARNING</b>	
	<b>ESD Sensitive Device:</b> This symbol and title inform that electronic boards and their components are sensitive to static electricity. Therefore, care must be taken during all handling operations and inspections of this product, in order to ensure product integrity at all times. Please read also the section "Special Handling and Unpacking Instructions".	
	<b>CE Conformity:</b> This symbol indicates that the product described in this manual is in compliance with all applied CE standards. Please refer also to the section "Regulatory Compliance Statements" in this manual.	

Disclaimer: We have tried to identify all situations that may pose a warning or a caution condition in this user's guide. However, Kontron does not claim to have covered all situations that might require the use of a Caution or a Warning.

## Unpacking

Follow these recommendations while unpacking:

- Remove all items from the box. If any items listed on the purchase order are missing, notify Kontron customer service immediately.
- Inspect the product for damage. If there is damage, notify Kontron customer service immediately.
- Save the box and packing material for possible future shipment.

## Powering Up the System

Before any installation or setup, ensure that the board is unplugged from power sources or subsystems.

If you encounter a problem, verify the following items:

- Make sure that all connectors are properly connected.
- Verify your boot devices.
- If the system does not start properly, try booting without any other I/O peripherals attached, including AMC adapters.

Make sure your system provides the minimum DC voltages required at the board's slot, especially if DC power is carried by cables.

If you are still not able to get your board running, contact our Technical Support for assistance.

## Adapter Cables

Because adapter cables come from various manufacturers, pinouts can differ. The direct crimp design offered by Kontron allows the simplest cable assembly. All cables are available from Kontron Sales Department.

## Storing Boards

Electronic boards are sensitive devices. Do not handle or store device near strong electrostatic, electromagnetic, magnetic or radioactive fields.

# Regulatory Compliance Statements

## *FCC Compliance Statement for Class A Devices*

This equipment has been tested and found to comply with the limits for a Class A digital device, pursuant to Part 15 of the FCC Rules. These limits are designed to provide reasonable protection against harmful interference in a residential installation. This equipment generated, uses and can radiate radio frequency energy and, if not installed and used in accordance with the instructions may cause harmful interference to radio communications. However, there is no guarantee that interference will not occur in a particular installation. If this equipment does cause harmful interference to radio or television reception, which can be determined by turning the equipment off and on, the user is encouraged to try to correct the interference by one or more of the following measures:

- Reorient or relocate the receiving antenna.
- Increase the separation between the equipment and receiver.
- Connect the equipment into an outlet on a circuit different from that to which the receiver is connected.
- Consult the dealer or an experience radio/TV technician for help.



### **WARNING**

This is a Class A product. If not installed in a properly shielded enclosure and used in accordance with this User's Guide, this product may cause radio interference in which case users may need to take additional measures at their own expense.



## *Safety Certification*

All Kontron equipment meets or exceeds safety requirements based on the IEC/EN/UL/CSA 60950-1 family of standards entitled, "Safety of information technology equipment." All components are chosen to reduce fire hazards and provide insulation and protection where necessary. Testing and reports when required are performed under the international IEC/EN/UL/CSA 60950-1 scheme. Please consult the "Kontron Safety Conformity Policy Guide" for more information. For Canada and USA input voltage must not exceed -60Vdc for safety compliance.

## *CE Certification*

The product(s) described in this user's guide complies with all applicable European Union (CE) directives if it has a CE marking. For computer systems to remain CE compliant, only CE-compliant parts may be used. Maintaining CE compliance also requires proper cable and cabling techniques. Although Kontron offers accessories, the customer must ensure that these products are installed with proper shielding to maintain CE compliance. Kontron does not offer engineering services for designing cabling systems. In addition, Kontron will not retest or recertify systems or components that have been reconfigured by customers.

## Limited Warranty

Kontron grants the original purchaser of Kontron's products a TWO YEAR LIMITED HARDWARE WARRANTY as described in the following. However, no other warranties that may be granted or implied by anyone on behalf of Kontron are valid unless the consumer has the express written consent of Kontron.

Kontron warrants their own products, excluding software, to be free from manufacturing and material defects for a period of 24 consecutive months from the date of purchase. This warranty is not transferable nor extendible to cover any other users or long-term storage of the product. It does not cover products which have been modified, altered or repaired by any other party than Kontron or their authorized agents. Furthermore, any product which has been, or is suspected of being damaged as a result of negligence, improper use, incorrect handling, servicing or maintenance, or which has been damaged as a result of excessive current/voltage or temperature, or which has had its serial number(s), any other markings or parts thereof altered, defaced or removed will also be excluded from this warranty.

If the customer's eligibility for warranty has not been voided, in the event of any claim, he may return the product at the earliest possible convenience to the original place of purchase, together with a copy of the original document of purchase, a full description of the application the product is used on and a description of the defect. Pack the product in such a way as to ensure safe transportation (see our safety instructions).

Kontron provides for repair or replacement of any part, assembly or sub-assembly at their own discretion, or to refund the original cost of purchase, if appropriate. In the event of repair, refunding or replacement of any part, the ownership of the removed or replaced parts reverts to Kontron, and the remaining part of the original guarantee, or any new guarantee to cover the repaired or replaced items, will be transferred to cover the new or repaired items. Any extensions to the original guarantee are considered gestures of goodwill, and will be defined in the "Repair Report" issued by Kontron with the repaired or replaced item.

Kontron will not accept liability for any further claims resulting directly or indirectly from any warranty claim, other than the above specified repair, replacement or refunding. In particular, all claims for damage to any system or process in which the product was employed, or any loss incurred as a result of the product not functioning at any given time, are excluded. The extent of Kontron liability to the customer shall not exceed the original purchase price of the item for which the claim exists.

Kontron issues no warranty or representation, either explicit or implicit, with respect to its products reliability, fitness, quality, marketability or ability to fulfil any particular application or purpose. As a result, the products are sold "as is," and the responsibility to ensure their suitability for any given task remains that of the purchaser. In no event will Kontron be liable for direct, indirect or consequential damages resulting from the use of our hardware or software products, or documentation, even if Kontron were advised of the possibility of such claims prior to the purchase of the product or during any period since the date of its purchase.

Please remember that no Kontron employee, dealer or agent is authorized to make any modification or addition to the above specified terms, either verbally or in any other form, written or electronically transmitted, without the company's consent.

# 1. Product Description

## 1.1 Product Overview

The RTM8050 is a single slot (6HP) AdvancedTCA Rear Transition Module. This RTM provides additional connectivity to the AT8050 CPU front board.

## 1.2 What's Included

This board is shipped with the following items:

- One RTM8050 board
- One RTMHDD board with SAS hard disk
- One CD-ROM containing documentations and drivers.
- Cables that have been ordered

If any item is missing or damaged, contact the supplier.

## 1.3 Board Specifications

Table 1-1: Board Specifications

Features	Description
Compatible Products	<ul style="list-style-type: none"> <li>• AT8050</li> </ul>
Compliance	<ul style="list-style-type: none"> <li>• PICMG3.0 R3.0 (see note in section 1.4)</li> <li>• SAS1R10</li> <li>• SFF-8470</li> <li>• IEEE 802.3z (fiber interface)</li> <li>• IEEE 802.3 (copper interface)</li> <li>• PICMG HPM.1</li> <li>• USB 2.0</li> </ul>
IPMI Features	<ul style="list-style-type: none"> <li>• Management Controller compliant to PICMG 3.0 and IPMI v2.0 .</li> <li>• Management Controller is run time field reprogrammable without payload impact.</li> <li>• Robust fail safe reprogramming implementation (which includes two firmware images) that could perform automatic or manual rollback if a problem occurs during critical reprogramming phase.</li> <li>• Remote upgrade capability (via IPMB).</li> <li>• Management Controller self test which can detect failure under its code integrity and trig an automatic rollback.</li> </ul>
Supervisory	<ul style="list-style-type: none"> <li>• Hardware system monitor through IPMI (voltages, currents, temperature), temperature monitor / alarm; board temperature sensor, power failure.</li> </ul>

Features	Description
Mechanical	<ul style="list-style-type: none"> <li>322.25 x 93.74 x 29 mm</li> </ul>
Power Requirements	<ul style="list-style-type: none"> <li>10W Typical without hard drive.</li> <li>20 W Typical with hard drive.</li> </ul>
Environmental Temperature*	Operating: 0-55°C/32-131°F with 30CFM airflow Storage and Transit: -40 to +70°C/-40 to 158°F
Environmental Humidity*	Operating: 15% to 90% @55°C/131°F non-condensing Storage and Transit: 5% to 95% @ 40°C/104°F non-condensing
Environmental Altitude*	Operating: 4,000 m / 13,123 ft Storage and Transit: 15,000 m / 49,212 ft
Environmental Shock*	Operating: 3G, half-sine 11ms, each axis Storage and Transit: 18G, half-sine 11ms, each axis
Environmental Vibration*	Operating: 5-200Hz. 0.2G, each axis Storage and Transit: 5 Hz to 20 Hz @ 1 m2/s3 (0.01 g2 /Hz) (flat) 20 Hz to 200 Hz @ -3 dB/oct (slop down)
Reliability	<ul style="list-style-type: none"> <li>Whole board protected by active breaker</li> <li>USB voltage protected by an active breakers</li> </ul>
Safety / EMC	<ul style="list-style-type: none"> <li>Safety: CE Mark to EN 60950-1:2001. Meets or exceeds UL 60950-1/CSA C22.2 No 60950-1-07.</li> <li>Designed to meet GR-1089-CORE</li> <li>EMI/EMC: FCC 47 CFR Part 15, Class A; CE Mark to EN55022/EN55024/EN300386</li> </ul>
Warranty	Two years limited warranty

\* Designed to meet or exceed

## 1.4 Compliance

This product conforms to the following specifications:

- PICMG3.0 R3.0 - Advanced Telecommunication Computing Architecture (see note below)
- PICMG HPM.1
- SAS1R10 - Serial Attached SCSI - 1.1 Revision 10. (SAS-1.1)
- SFF-8470 (T10 Technical Committee and SCSI Trade Association)
- IEEE 802.3z (fiber interface)
- IEEE 802.3 (copper interface)



### Note:

Board might not be 100% compliant to ATCA PICMG 3.0 Specification REQ 4.94 when a hard drive is present on the RTMHDD. The HDD might connect the Logic Ground and the Shelf Ground. By default the Logic Ground and the Shelf Ground are connected through a removable screw.

## 1.5 Hot-Swap Capability

The RTM8050 supports Full Hot Swap capability as per PICMG3.0R3.0. It can be removed from or installed in the system while it is on (without powering-down the system). Please refer to the PICMG3.0R3.0 specification for additional details.



### WARNING

All the managements infrastructures are present for hot-swap, but the user must take the proper action to protect its data under the OS installed on the Front Board (such as unmount a SAS drive)



## 1.6 Interfacing with the Environment

### 1.6.1 RTM (rear transition module)

The RTM8050 is a single slot (6HP) AdvancedTCA Rear Transition Module. This module provides additional connectivity for AT8050 CPU front board.

#### 1.6.1.1 SAS Feature

- Compliant to SAS-1.1 Revision 10 / SFF-8470
- SAS signal integrity guarantee over a four meters cable

#### 1.6.1.2 Serial Port Feature

- One (1) serial port available on the RTM face plate through one (1) RJ-45 connector
- RS-232 signals level at RTM face plate connector.
- Serial port speed capability is: 9.6kbits/s to 115.2kbits/s.

#### 1.6.1.3 FRU Data EEPROM

- FRU Data EEPROM size is 32Kbit and it includes board identification and serial number.

#### 1.6.1.4 Hot Swap

As a Hot Swappable Intelligent Managed FRU, the RTM8050 (FRU2) includes a Management Controller, the AdvancedTCA Hot Swap indicator (Blue LED), and the standard AdvancedTCA handle switch.

The RTM8050 includes a PCI-Express SAS controller; proper PCI-Express Hot-Plug support is required in O/S to complete hot-extract and hot-insert cycles.

As a Hot Swappable Non-Intelligent Managed FRU, the RTMHDD (FRU3) mezzanine adds support for SAS hot swapping; it includes its own ejector latch and Blue LED, under control of the front board's IPMC.



#### 1.6.1.4.1 Insertion and Removal of the Managed FRUs

After insertion, the front board detects and activates the management components of the FRU. When the handle is closed, the power budget and the e-keying negotiations start. Then, the front board's IPMC activates the payload components of the FRU.

Opening the RTM handle switch on the RTM FRU and will start the deactivation process, which either deactivates the whole board (front board, RTM and RTMHDD) or only the RTM8050 and its RTMHDD mezzanine, depending on a configuration policy available through the CMOS configuration menu.

The operational state of the FRU is reported through the management subsystem FRU Hot Swap sensors. The BLUE LED is 100% off when a FRU is operational and unsafe for extraction. An always on(100%) indicates that a FRU can safely be extracted; transitional states are identified through blinking patterns. Additional details on the standard FRU Hot Swap sensor and the BLUE LED usage can be found in the AdvancedTCA specifications.

# 2. Board Features

## 2.1 Block Diagram

Figure 2-1: Block Diagram

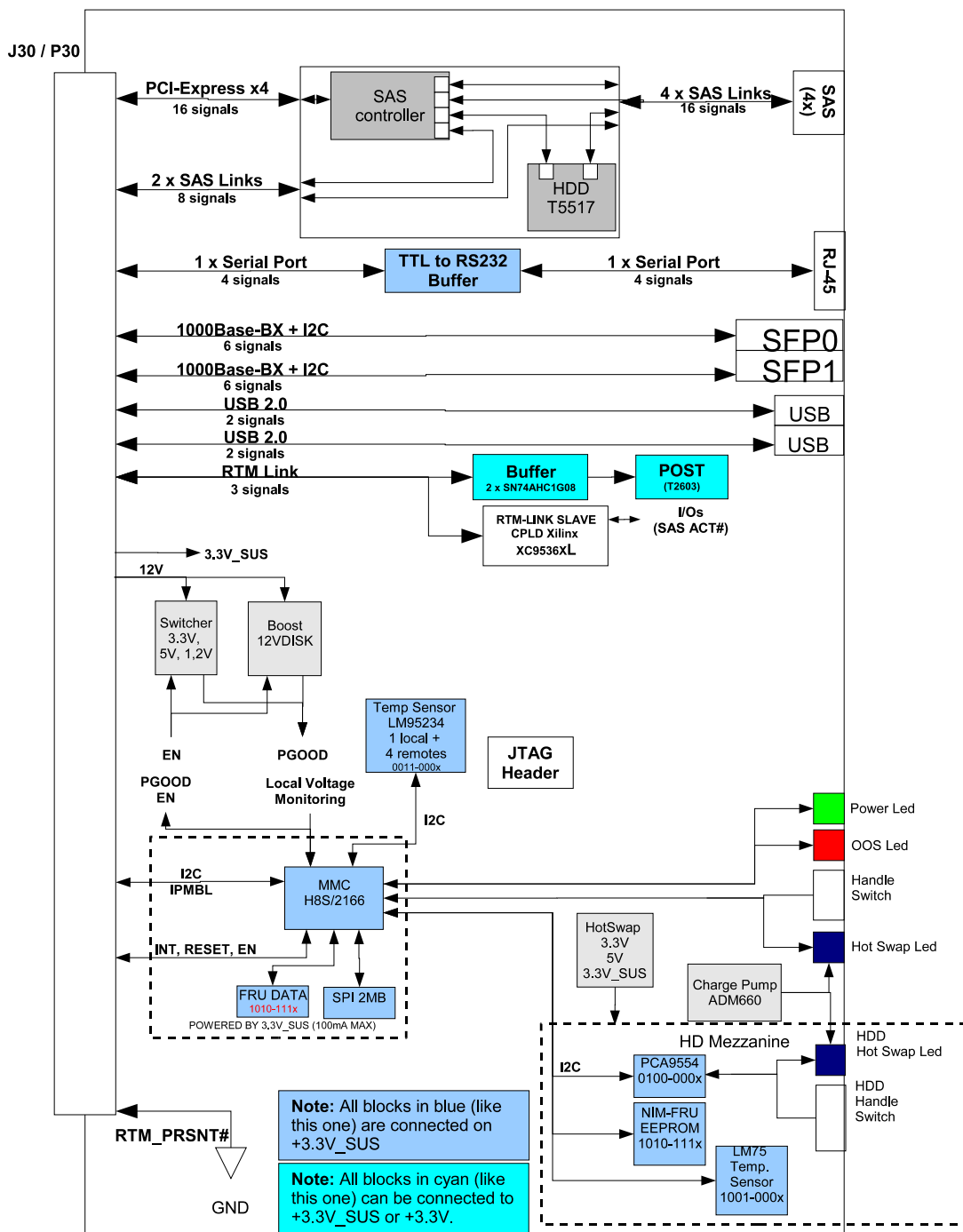

## 2.2 USB 2.0 Interface

The RTM8050 feature two USB connectors on the faceplate.

USB features include:

- Capability to daisy chain as many as 127 devices per interface
- Fast bi-directional
- Isochronous/asynchronous interface
- 480 MBPS transfer rate
- Standardization of peripheral interfaces into a single format
- Backward compatible with USB 1.1 devices

USB supports Plug and Play and hot-swapping operations (OS level). These features allow USB devices to be automatically attached, configured and detached, without reboot or running setup.

Table 2-1:USB Connector Pinout

Pin	Signal
1	VCC
2	DATA-
3	DATA+
4	GND



### Signal Path:

The USB Port are available through the RTM face plate (J7).

## 2.3 SAS Onboard Controller

The SAS controller is only offered through the RTM on which the controller is located. The controller used is the 4 ports PCI-express from LSI: LSI SAS1064e. The controller has access to

- Front board AMC bay SAS port
- HDD mounted on RTM8050
- Two external links

To achieve a redundant scheme two more interfaces are routed from external connector to RTM and AMC HDDs.

## 2.4 HD Mezzanine Hot-Swap Option

Kontron offers the possibility to add a Hot-Swap SAS hard drive on the RTM8050. This hard drive is located on the lower part of the RTM8050. The Hotswap infrastructure includes Hotswap LED, Hotswap handle, hard disk presence status, thermal sensor and Non-Intelligent-Managed-FRU EEPROM. All of which are connected to the MMC. The HD supported is a SAS drive. This module is called RTMDISK. It is managed by the IPMC and presented as a regular managed FRU to management subsystem.

## 2.5 Serial Port

The RTM8050 has one serial port available on the face plate. Serial ports is coming from the front board through zone 3 connector. RS232 buffers are used to convert LVTTTL level from zone 3 to RS232 level at the face plate connector. Serial port works from 9.6 to 115.2 kbits/s.

Table 2-2:Serial Port Connector Pinout

Pin	Signal
1	RTS
1	DTR
3	TX#
4	GND
5	N.C.
6	RX#
7	N.C.
8	CTS



### Note:

Standard product uses a RJ-45 8 pins connector. RI (ring indicator) and DCD (data carrier detect) signals are not available. The pinout is a custom one, not the same as RS-232D TIA/EIA-561.



### Signal Path:

Serial port is available on the RTM face plate through J9.

## 2.6 SFP

The RTM8050 has two SFP modules connectors available on the RTM face plate. The SFP module signals are coming from the front board 1000Base-KX interface through zone 3 connector.

## 2.7 MMC Boot Block

The MMC runs a firmware from its internal 256KB flash. It is programmed by an additional 8K boot block. It keeps the last two copies of the MMC firmware in dedicated flash memories. The boot block activates the MMC image and can rollback a firmware update in the MMC in case of problems.

## 2.8 Hardware Management Overview

The RTM communicates with the front board using the IPMB-L channel. Kontron Intelligent RTM address on the IPMB-L is fixed and has a value of 0xA6.

The memory subsystem of the MMC consists of an integrated flash memory to hold the MMC operation code and integrated RAM for data. The field replacement unit (FRU) inventory information is stored in the nonvolatile memory on an EEPROM connected via a local I2C interface to the MMC. It is possible to store up to 4 KBytes within the FRU inventory information. Event generation over IPMB-L bus to reach the front board that forward it to the ShMc ensure that 'post-mortem' logging information is available even if the power of the RTM is disabled.

The onboard DC voltages and temperature are monitored by the MMC device. The MMC will send an event to the front board if any of the thresholds are exceeded.

To increase the reliability of the RTM8050 management subsystem, an external watchdog supervisor only for the MMC is implemented. The MMC must strobe the external watchdog at 500  $\mu$ sec. intervals to ensure continuity of operation of the board's management subsystem. If the MMC ceases to strobe the watchdog supervisor, the watchdog resets the MMC. The watchdog timeout expires after one second if strobes are not generated. The external watchdog supervisor is not configurable and must not be confused with the IPMI v1.5 watchdog timer commands. This external watchdog of the MMC is implemented in a separate chip.

### 2.8.1 Sensor Data Record (SDR)

Every sensor on the RTM is associated with a Sensor Data Record (SDR). Sensor Data Records contain information about the sensors identification such as sensor type, sensor name, sensor unit. SDR also contain the configuration of a specific sensor such as threshold/hysteresis, event generation capabilities that specifies sensor behaviour. Some fields of the sensor SDR are configurable through IPMI v1.5 command and are set with built-in initial value. Finally one field which is the sensor owner must reflect the module addresses that allow a system management software to identify the owner of the SDR when it is scanned from the front board IPMC and merged within the IPMC Device SDR repository.

From IPMI perspective, the RTM8050 management controller is set up as a satellite management controller (SMC). It does support sensor devices, and use the IPMI static sensor population feature of IPMI v1.5 to merge the hot swapped RTM sensor with the front board sensors population. The usual way the SHMC is informed about an RTM insertion is through the RTM Module Hot Swap sensor and a radial presence line on the RTM connector. All SDRs can be queried using Device SDR commands to the firmware. Module sensors that have been implemented are listed below.

## 2.8.2 Hardware Sensors

Table 2-3:IPMI Hardware Sensors

IPMI sensor ID	Sensor Name	Description (Sensor Type, Event trigger)	Scanning Enabled under Power State	Health LED (Green to Amber)
0	Module HS	Hot Swap state	*	N
1	Temp Air In	Ait Inlet Temperature (Degrees)	*	X
2	Temp Air Out	Ait Outlet Temperature (Degrees)	*	X
3	Temp SASCtrl	LSI SAS Controller Temperature (Degrees)	*	X
4	Temp MMC	Module Management Controller Temperature (Degrees)	*	X
5	Vcc +3.3VSUS	Voltage on board 3.3V suspend (management) power supply	*	X
6	Vcc +3.3V	Voltage on board 3.3V backend power supply	-	X
7	Vcc +5V	Voltage on board 5V backend power supply	-	X
8	Vcc +1.2V	Voltage on board 1.2V backend power supply	-	X
9	Vcc BlueLED	Voltage on board blue LED VPUMP suspend power supply	*	X
10	Vcc +12V	Voltage on board 12V payload power supply	-	X
11	Vcc +12VDisk	Voltage on board 12V payload disk power supply	-	X
12	SFP-A Pres	SFP-A Slot/Connector Status	-	
13	SFP-A OC	SFP-A Over Current Status	-	X
14	SFP-B Pres	SFP-B Slot/Connector Status	-	
15	SFP-B OC	SFP-B Over Current Status	-	X
16	USBO OC	USB Over Current Status	-	X
17	USB1 OC	USB Over Current Status	-	
18	Disk Bay	Removable Disk Bay Slot/Connector Status	*	X
19	Power State	Board Power State	*	X
20	Power Good	Actual power good status	*	X
21	Pwr Good Ev	Power good status event that occur since the last power on or reset	-	X
22	Health Error	General health status	*	
23	Ver change	Firmware Change Detection	*	
24	IPMBL State	IPMB-L branch from FRU0 fault detection sensor	*	
25	FRU Agent	FRU Information Agent - FRU0 Data Error Detection	*	
26	MMC Reboot	IPMC reboot detection	*	
27	MMC FwUp	Kontron OEM IPMC firmware upgrade Status	*	
28	MMC Stor Err	Management sub-system health: non volatile memory error	*	
29	IPMI Info-1	Internal Management Controller firmware diagnostic	*	
30	IPMI Info-2	Internal Management Controller firmware diagnostic	*	

X Exceed critical threshold / Error Assertion

\* Power On/Off

- Power On

N No change

### 2.8.2.1 IPMB-L Link Sensor

The RTM8050 has an IPMB-L link to communicate with the processor board and other devices in the chassis chassis IPMB-0 bus. MMC monitors the bus for any link failure and sends the bus failure event to the front board upon the recovery occurs.

## 2.8.3 Field Replaceable Unit (FRU) Information

The FRU Information provides inventory data about the boards where the FRU Information Device is located. The part number or version number can be read through software.

FRU information in the RTM8050 includes data describing the RTM8050 board similar to AMC.0 R2.0 specification requirements. This information is retrieved by the RTM, enabling reporting of board-specific information through a standardized mechanism.

Table 2-4:Board Information Area

Board Information Area	
Field Description	Value (hex)
Format Version	0x01
Board Area Length	*Calculated
Language code	0x00
Manufacturing Date / Time	*Based on mfg. date
Board Manufacturer type/length	*Calculated
Board Manufacturer	"Kontron"
Board Product Name type/length	*Calculated
Board Product Name	"RTM8050"
Board Serial Number type/length	*Calculated
Board Serial Number	Manufacturer S/N
Board Part Number type/length	*Calculated
Board Customer Part Number	"T5705###_R"
FRU File ID type/length	*Calculated
FRU File ID	"FRU5705-YY"
No more fields	0xC1
Padding	0x00
Board Area Checksum	*Calculated

Table 2-5:Product Information Area

Product Information Area	
Field Description	Value (hex)
Format Version	0x01
Product Area Length	*Calculated
Language Code	0x00
Manufacturer Name type/length	*Calculated

Product Information Area	
Manufacturer Name	"Kontron"
Product Name type/length	*Calculated
Product Name	"RTM8050"
Product Part/Model Number type/length	*Calculated
Product Part/Model Number	"T5705_XX"*
Product Version type/length	*Calculated
Product Version	"XX" *
Product Serial Number type/length	*Calculated
Product Serial Number	Manufacturer S/N
Asset Tag type/length	0xC0
Asset Tag	
FRU File ID type/length	*Calculated
FRU File ID bytes	"FRU5705-YY" **
No more fields	0xC1
Padding	0x00
Product Info Area Checksum	*Calculated

Table 2-6: Type 16 Module Current Requirements Records

Type 16 – Module Current Requirements Record	
Record Type ID	C0h
Record format version	02h
Manufacturer ID	00315Ah (PICMG Record ID)
PICMG Record ID	16h (Module Power Descriptor table)
Record Format Version	00h
Current Draw	0Ch (1.2 Amps at 12 V => 14.4 Watts)

## 2.8.4 MMC Firmware Code

MMC firmware code is organized into boot code and operational code, both of which are stored in a flash module. Upon an MMC reset, the MMC executes the boot code and performs the following:

- 1 Self test to verify the status of its hardware and memory.
- 2 Performs a checksum of the operational code.
- 3 Set operational state that tells the boot block the firmware operate correctly.

Upon successful verification of the operational code checksum, the firmware will jump to the operational code.



## 2.8.5 MMC Firmware Upgrade Procedure

The upgrade procedure is compliant to PICMG HPM.1. MMC Firmware upgrades can be done by using IPMITOOL from [sourceforge](#) from the front board or remotely on the chassis. It has been designed to upgrade through any IPMI interface without payload impact.

## 2.8.6 Boot Block Upgrade Procedure

Type the following to perform MMC firmware upgrade

```
ipmifwu -fb <file> -P /dev/ttyS1 -M rtm -p <ENTER>
```



### Note:

During boot block firmware upgrade the MMC is held in reset

### 2.8.6.1 Hot-Swap Process

The RTM8050 has the ability to be hot-swapped in and out of the front board. The onboard MMC manages the RTM's power-up and power-down transitions. The list below illustrates this process for power down request.

- 1 Ejector latch is opened. HOT\_SWAP\_PB# assertion. MMC firmware detects the assertion of this signal.
- 2 MMC sends "Module Handle Open" event message to the front board. The corresponding M state of the front board moves from M4-> M5.
- 3 The front board moves from M5 -> M6 if the SHMC grants the request. The front board IPMC sends the FRU control requesting quiesced state to the RTM.
- 4 The firmware deasserts payload power and sends "Module Quiesced" event message to the front board where it transitions from M6 to M1 state.



### Note:

Depending on your BIOS configuration, a hot-swap process might turn off the front board. Please refer to the BIOS section "**Managed FRU Deactivation Policies**" of the AT8050.

### 2.8.6.2 Hot-Swap LED

The RTM8050 and RTMDISK support a blue Hot Swap LED mounted on the front panel. This LED indicates when it is safe to remove the RTM from the front board or the hard disk from the RTM. The on-board MMC drives this LED to indicate the hot-swap state. The following states are possible:

Table 2-7:Hot-Swap LED Description

LED state	Description
OFF	M4 state; normal state when board is in operation.
ON	M1 state; ready for hot swap.
Short blink	M5 state; deactivation request
Long blink	M2 state; activation request.

When the RTM latch is disengaged from the faceplate, the hot swap switch embedded in the PCB will assert a "HOT\_SWAP\_PB#" signal to the MMC, and the MMC will send "Module Handle Open" event message to the front board which moves from the M4 state to the M5 state. At the M5 state, the front board will ask the SHMC (or Shelf Manager) for permission to move the RTM to the M6 state. Then the IPMC of the front board, through IPMB-L, will set the RTM/HDD Hot Swap LED to indicate this state with a short blink. Once permission is received from the SHMC or higher-level software, the front board will move to the M6 state.

The SHMC or higher level software can reject the request to move to the M6 state. If this occurs, the RTM/HDD will return the Hot Swap LED to a solid off condition, indicating that the RTM has returned to M4 state.

If the RTM/HDD reaches the M6 state through an extraction request through the RTM/HDD handle latch, the MMC communicates to the front board that the module must discontinue operation in preparation for removal. The Hot Swap LED continues to flash during this preparation time, just like it does at the M5 state. When main RTM/HDD payload power is successfully removed from the RTM/HDD slot, the Hot Swap LED remains lit, indicating it is safe to remove the RTM from the chassis or the hard disk from the RTM.

Refer to the AT8050 manual for information on "Managed FRU Deactivation Policies" affecting the FRU deactivation process.

## 2.9 Face Plate Indicators

All LEDs can be overridden with standard PICMG LED APIs

### 2.9.1 Hot Swap LED (LED0)

The Blue / Hot Swap LED indicates the hot swap status of the RTM. The LED is ON when it is safe to remove the RTM from the slot. During normal operation, this LED is OFF.

### 2.9.2 Out Of Service (LED1)

The AdvancedTCA LED1 is red or amber and indicates an Out-of-Service (OOS) condition. During normal operation, the OOS LED is OFF. This LED is ON during firmware upgrade and is user configurable if needed by a customer application.

### 2.9.3 Healthy LED (LED2)

The AdvancedTCA LED2 is green or amber and indicates a healthy condition. The healthy LED indicates if the blade is powered up and all voltages and temperatures are within specifications. During normal operation, this LED is ON (green). This LED is also ON (amber) when one of the RTM8050 voltage or temperature fails.

### 2.9.4 RTMDISK Hot Swap LED

The Blue / Hot Swap LED indicates the hot swap status of the RTMDISK. The LED is ON when it is safe to remove the RTMDISK from the RTM. During normal operation, this LED is OFF.

## 3. Hot Swap and Installation

### 3.1 RTM Hot Swap and Installation

Because of the high-density pinout of the hard-metric connector, some precautions must be taken when connecting or disconnecting a RTM to/from an AT8050:

- 1 Rail guides must be installed on the enclosure to slide the RTM to the AT8050.
- 2 Do not force the RTM if there is mechanical resistance while inserting it.
- 3 Screw the faceplate to the enclosure to firmly attach the RTM to its enclosure.
- 4 Use extractor handles to disconnect and extract the RTM from its enclosure.



#### WARNING

Always use a grounding wrist wrap before installing or removing the board from a chassis.



#### 3.1.1 Installing the RTM in the chassis

To install the RTM:

- 1 Remove the filler panel of the slot.
- 2 Ensure the RTM is configured properly.
- 3 Carefully align the PCB edges at the bottom and top card guide.
- 4 Insert the RTM in the system until it makes contact with the CPU board.
- 5 Using both ejector handles, engage the RTM in the CPU board connectors until both ejectors are locked.
- 6 Fasten screws at the top and bottom of the faceplate.

#### 3.1.2 Removing the RTM from the chassis

To remove the RTM:

- 1 Unscrew the top and the bottom screw of the faceplate.
- 2 Unlock the lower handle latch.
- 3 Wait until the blue LED is fully ON, this mean that the hot swap sequence is ready for RTM removal.
- 4 Use both ejectors to disengage the RTM from the CPU board.
- 5 Pull the RTM out of the chassis.

## 3.2 RTMHDD Hot Swap and Installation

### 3.2.1 Installing the Hot Swap RTMHDD

To install the RTMHDD:

- 1 Carefully engage the RTMHDD into the guide. Push it until it fully mate with its connector. Secure the hard disk handle to the locking position.
- 2 The blue LED shall turn ON as soon as the RTMHDD is fully inserted. It will turn OFF at the end of the hot swap sequence.

### 3.2.2 Removing the Hot Swap RTMHDD

To remove the RTMHDD:

- 1 Pull out the handle to unlock the RTMHDD.
- 2 Wait for the blue LED to turn solid on (100% on).
- 3 Pull out the RTMHDD using the handle.

# A. Connector Pinouts

## A.1 Connectors and Headers Summary

Connector	Description
P30	RTM Connector
J1	SAS Connector
J4	SFP Connector
J5	SFP Connector
J7	Dual USB Connectors
J9	RJ-45 Serial Port Connector
J13	Hot Swap Hard Disk Module

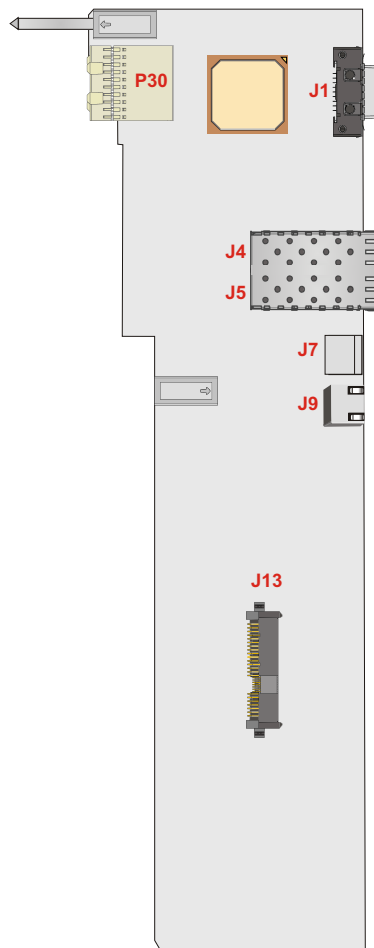

## A.2 AdvancedTCA I/O RTM Connector (P30)

Pin	ROW A	ROW B	ROW C	ROW D	ROW E	ROW F
1	V_12V_1	V_12V_5	V_12V_2	V_3V2_SUS	FPGA_IO_3	RTM_PRSNT#
2	V_12V_3	V_12V_6	V_12V_4	NC_D2	IPMC_SCL	IPMC_SDA
3	SP_TX	SP_RX	JTAG_TD1	JTAG_TD0	JTAG_TMS	JTAG_TCK
4	USB1_D+	USB1_D-	INT_0	INT_1	RTML_TX	RTML_RX
5	SP_RTS#	SP_CTS#	MD2#	SRSVD_D5	CLK_PE+	CLK_PE-
6	SATA_TX+	SATA_TX-	SATA_RX+	SATA_RX-	SFP1_SCL	SFP1_SDA
7	SAS_0_TX+	SAS_0_TX-	SAS_0_RX+	SAS_0_RX-	SAS_1_TX-	SAS_1_TX+
8	GBE_TX1+	GBE_TX1-	GBE_RX1+	GBE_RX1-	GBE_TX2+	GBE_TX2-
9	PE6_TX-	PE6_TX+	PE7_RX-	PE7_RX+	PE5_TX+	PE5_TX-
10	PE4_TX-	PE4_TX+	PE5_RX+	PE5_RX-	PE7_TX+	PE7_TX-

Pin	ROW G	ROW H	ROW AB	ROW CD	ROW EF	ROW GH
1	FPGA_IO_1	RTM_EN#	GND	GND	GND	GND
2	USB0_D+	USB0_D-	GND	GND	GND	GND
3	JTAG_TRST	FPGA_IO_2	GND	GND	GND	GND
4	RTML_CLK	PROG	GND	GND	GND	GND
5	RSVD_G5	JTAG_SEL	GND	GND	GND	GND
6	SFPO_SCL	SFPO_SDA	GND	GND	GND	GND
7	SAS_1_RX+	SAS_1_RX-	GND	GND	GND	GND
8	GBE_RX2+	GBE_RX2-	GND	GND	GND	GND
9	PE6_RX-	PE6_RX+	GND	GND	GND	GND
10	PE4_RX-	PE4_RX+	GND	GND	GND	GND

## A.3 SAS Faceplate Connector (J1)

Pin	Signal	Pin	Signal
S1	RX_0+	G1	GND
S2	RX_0-	G2	GND
S3	RX_1+	G3	GND
S4	RX_1-	G4	GND
S5	RX_2+	G5	GND
S6	RX_2-	G6	GND
S7	RX_3+	G7	GND
S8	RX_3-	G8	GND
S9	TX_3-	G9	GND
S10	TX_3+		
S11	TX_2-	MTG1	CGND_1
S12	TX_2+	MTG2	CGND_2
S13	TX_1-		
S14	TX_1+		
S15	TX_0-		
S16	TX_0+		

## A.4 SFP Channel (J4 & J5)

Pin	Signal	Pin	Signal	Pin	Signal
1	VEET_1	11	VEER_3	21	cGND_1
2	TX_FAULT	12	RD-	22	cGND_2
3	TX_DIS	13	RD+	23	cGND_3
4	MODDEF2	14	VEER_4	24	cGND_4
5	MODDEF1	15	VCCR	25	cGND_5
6	MODEFF0	16	VCCT	26	cGND_6
7	R_SEL (N.C.)	17	VEET_2	27	cGND_7
8	LOS	18	TD+	28	cGND_8
9	VEER1	19	TD-	29	cGND_9
10	VEER2	20	VEET_3	30	cGND_10
				31	cGND_11

## A.5 Dual USB Port (J7)

Pin	Signal
1	VCC
2	DATA-
3	DATA+
4	GND

## A.6 Serial Port(J9)

Pin	Signal
1	RTS
2	DTR
3	TX#
4	GND
5	N.C.
6	RX#
7	N.C.
8	CTS

## A.7 Hot Swap Hard Disk Module(J13)

Pin	Signal	Pin	Signal
S1	GND	P1	3.3V_SUS_HD
S2	PortA_TX+	P2	3.3V
S3	PortA_TX-	P3	3.3V_PRE
S4	GND	P4	SMB_SCL
S5	PortA_RX-	P5	HD_PRESENT#
S6	PortA_RX+	P6	GND
S7	GND	P7	5V_PRE
S8	GND	P8	5V
S9	PortB_TX+	P9	5V
S10	PortB_TX-	P10	V_PUMP_R
S11	GND	P11	SMB_SDA
S12	PortB_RX-	P12	GND
S13	PortB_RX+	P13	12V_PRE
S14	GND	P14	12V
		P15	12V



---

## B. Software Update

### B.1 MMC Firmware Update Procedure

To update the software of your board, it is recommended to use the update CD, please contact you local technical support departement for the proper procedure to follow.

---

## C. Getting Help

If, at any time, you encounter difficulties with your application or with any of our products, or if you simply need guidance on system setups and capabilities, contact our Technical Support at:

North America	EMEA
Tel.: (450) 437-5682	Tel.: +49 (0) 8341 803 333
Fax: (450) 437-8053	Fax: +49 (0) 8341 803 339

If you have any questions about Kontron, our products, or services, visit our Web site at: [www.kontron.com](http://www.kontron.com)

You also can contact us by E-mail at:

North America: [support@ca.kontron.com](mailto:support@ca.kontron.com)

EMEA: [support-kom@kontron.com](mailto:support-kom@kontron.com)

Or at the following address:

North America	EMEA
Kontron Canada, Inc.	Kontron Modular Computers GmbH
4555, Ambroise-Lafortune	Sudetenstrasse 7
Boisbriand, Québec	87600 Kaufbeuren
J7H 0A4 Canada	Germany

### C.1 Returning Defective Merchandise

Before returning any merchandise please do one of the following:

- Call
  - 1 Call our Technical Support department in North America at (450) 437-5682 and in EMEA at +49 (0) 8341 803 333. Make sure you have the following on hand: our Invoice #, your Purchase Order #, and the Serial Number of the defective unit.
  - 2 Provide the serial number found on the back of the unit and explain the nature of your problem to a service technician.

- 
- 3 The technician will instruct you on the return procedure if the problem cannot be solved over the telephone.
  - 4 Make sure you receive an RMA # from our Technical Support before returning any merchandise.

- E-mail

- 1 Send us an e-mail at: [RMA@ca.kontron.com](mailto:RMA@ca.kontron.com) in North America and at: [orderprocessing@kontron-modular.com](mailto:orderprocessing@kontron-modular.com) in EMEA. In the e-mail, you must include your name, your company name, your address, your city, your postal/zip code, your phone number, and your e-mail. You must also include the serial number of the defective product and a description of the problem.

## C.2 When Returning a Unit

- In the box, you must include the name and telephone number of a contact person, in case further explanations are required. Where applicable, always include all duty papers and invoice(s) associated with the item(s) in question.
- Ensure that the unit is properly packed. Pack it in a rigid cardboard box.
- Clearly write or mark the RMA number on the outside of the package you are returning.
- Ship prepaid. We take care of insuring incoming units.

North America	EMEA
Kontron Canada, Inc.	Kontron Modular Computers GmbH
4555, Ambroise-Lafortune	Sudetenstrasse 7
Boisbriand, Québec	87600 Kaufbeuren
J7H 0A4 Canada	Germany

## D. Glossary

Acronyms	Descriptions
ACPI	Advanced Configuration & Power Interface
AdvancedMC	(Same as AMC). Advanced Mezzanine Card.
AMC	(Same as AdvancedMC). Advanced Mezzanine Card.
AMC.0	Advanced Mezzanine Card Base Specification.
AMC.1	PCI Express and Advanced Switching on AdvancedMC. A subsidiary specification to the Advanced Mezzanine Card Base Specification (AMC.0).
AMC.2	Ethernet Advanced Mezzanine Card Specification. A subsidiary specification to the Advanced Mezzanine Card Base Specification (AMC.0).
AMC.3	Advanced Mezzanine Card Specification for Storage. A subsidiary specification to the Advanced Mezzanine Card Base Specification (AMC.0).
ATCA	Advanced Telecommunications Computing Architecture
BIOS	Basic Input/Output System
CMOS	Complementary Metal Oxide Semiconductor. Also refers to the small amount of battery (or capacitor) powered CMOS memory to hold the date, time, and system setup parameters.
CPU	Central Processing Unit. This sometimes refers to a whole blade, not just a processor component.
CTS	Clear To Send
DTR	Data Terminal Ready
EMI	ElectroMagnetic Interference
FCC	Federal Communications Commission
FRU	Field Replaceable Unit. Any entity that can be replaced by a user in the field. Not all FRUs are hot swappable.
GND	GrouND
HDD	Hard Disc Drive
HPM	PICMG Hardware Platform Management specification family
HPM.1	Hardware Platform Management IPM Controller Firmware Upgrade Specification
I2C	Inter Integrated Circuit bus
ID	IDentification
IEEE	Institute of Electrical and Electronics Engineers
IPM	Intelligent Platform Management
IPMB	Intelligent Platform Management Bus
IPMB-0	Intelligent Platform Management Bus Channel 0, the logical aggregation of IPMB-A and IPMB-B.
IPMB-A	Intelligent Platform Management Bus A
IPMB-B	Intelligent Platform Management Bus B
IPMB-L	Intelligent Platform Management Bus Local
IPMC	Intelligent Platform Management Controller
IPMI	Intelligent Platform Management Interface
IPMIFWU	Intelligent Platform Management Interface FirmWare Update
LED	Light-Emitting Diode
MMC	Module Management Controller. MMCs are linked to the IPMC.
NC	Not Connected
OOS	Out Of Service

---

Acronyms	Descriptions
OS	Operating System
PICMG	PCI Industrial Computer Manufacturers Group
PICMG®	PCI Industrial Computer Manufacturers Group
POST	Power-On Self-Test
RAM	Random Access Memory
RS-232	(Same as RS232). Recommended Standard 232.
RS232	(Same as RS-232). Recommended Standard 232.
RTM	Rear Transition Module
RTS	Request To Send
SAS	Serial Attached SCSI
SFP	Small Form-factor Pluggable
ShMC	Shelf Management Controller
TX	Transmit
TXD	Transmit
USB	Universal Serial Bus
VCC	Power supply