



VRack 4U Systems

User's Guide (prelim. version V0.99 prelim)

This page is intentionally left blank.

1. Table of Contents

1. Table of Contents	1
1.1. Table of Figures.....	3
2. Introduction	4
2.1. Symbols used in this Manual.....	5
3. Important Instructions	6
3.1. Warranty Note	6
3.2. Exclusion of Accident Liability Obligation.....	6
3.3. Liability Limitation / Exemption from the Warranty Obligation	6
4. General Safety Instructions for IT Equipment	7
4.1. Operation of Laser Source Devices	8
4.2. Electrostatic Discharge (ESD)	9
4.2.1. Grounding Methods.....	9
4.3. Instructions for the Lithium Battery.....	9
5. Electromagnetic Compatibility (Class A Device)	10
5.1. Electromagnetic Compatibility (EU)	10
5.2. FCC Statement (USA).....	10
5.3. EMC Compliance (Canada)	10
6. Scope of Delivery	11
6.1. Type Label and Product Identification	11
7. Product Description	12
7.1. Front Side.....	15
7.1.1. Interfaces and Controls on the Front Side	17
7.1.2. Controls and Indicators.....	17
7.1.3. Front Access Panel	18
7.1.4. Cover Fastening Screw on the Front Side	18
7.1.5. Filter Mat and Filter Mat Holder	19
7.1.6. Drive Bays	19
7.2. Rear Side	20
7.2.1. Power Supply	20
7.2.2. External Interfaces of the DZ77-SL-50K Motherboard.....	21
7.2.3. External Interfaces of the KTQ45/ATXE Motherboard.....	21
7.3. Side View	22
7.4. Fans.....	22
8. Assembly, Disassembly	23
8.1. Attaching the Rubber Feet	23
8.2. Cover	23
8.3. Accessing Internal Components	24
8.3.1. Installing/Removing the Expansion Cards	24
8.4. Installation in a 19" Industrial Cabinet	26
9. Starting Up	27
9.1. AC Power Connection	27
9.2. Operating System and Hardware Component Drivers	28

10. Maintenance and Prevention	29
10.1. Cleaning the Filter Mat	29
10.2. Replacing the Lithium Battery	31
11. Slide Rails (Option)	32
12. Technical Data	33
12.1. Electrical Specifications	33
12.2. Mechanical Specifications	34
12.3. Environmental Specifications	34
12.4. CE Directives and Standards	35
13. Standard Interfaces – Pin Assignments	36
13.1.1. Serial Interface (RS232)	36
13.1.2. VGA Port	36
13.1.3. Combined PS/2 Keyboard and Mouse Connector	37
13.1.4. PS/2 Keyboard Connector	37
13.1.5. PS/2 Mouse Connector.....	37
13.1.6. Parallel Port (LPT).....	38
13.1.7. USB Port	38
14. Technical Support	39
14.1. Returning Defective Merchandise	39

1.1. Table of Figures

Fig. 1: Laser radiation warning label	8
Fig. 2: VRack 4U - configuration with DVD drive and internal HDD	11
Fig. 3: VRack 4U - configuration with DVD and DA435 drives	11
Fig. 4: VRack 4U - side view with opened access panel.....	12
Fig. 5: VRack 4U, opened (shown as VRack DZ77-A with external accessible drives only	13
Fig. 6: VRack 4U opened (shown as VRack 4U DZ77-A with internal HDD and external accessible drive).....	14
Fig. 7: Front side with closed front access panel	15
Fig. 8: Front side with opened access panel	16
Fig. 9: Controls, indicators and USB ports at the front side	17
Fig. 10: LED indicators on the front side.....	18
Fig. 11: Front accessible drive bays (e.g. D1 equipped with a DVD drive).....	19
Fig. 12: Rear side of a VRack 4U platform (shown as VRack DZ77-A; the expansion cards are as example only)	20
Fig. 13: External ports of the Intel® DZ77 motherboard	21
Fig. 14: External ports of the KTQ45/ATXE motherboard	21
Fig. 15: VRack 4U platform – side view	22
Fig. 16: Inside of the cover with fixing brackets.....	23
Fig. 17: Loosening the knurled cover fastening screw on the front side	25
Fig. 18: Pull out the cover with the fixing bolts on the rear	25
Fig. 19: VRack with removed cover	25
Fig. 20: VRack 4U, rear side (shown as VRack 4U DZ77-A)	27
Fig. 21: Detail: Filter mat holder on the front side of the VRack 4U platform	29
Fig. 22: Detail: without filter mat at the front side	30
Fig. 23: Filter mat holder without filter mat	30
Fig. 24: Filter mat holder with filter mat.....	30
Fig. 25: Filter mat	30
Fig. 26: Lithium Battery location	31

2. Introduction

Kontron Technology India would like to point out that the information contained in this manual may be subject to technical alteration, particularly as a result of the constant upgrading of Kontron Technology India products. The attached documentation does not entail any guarantee on the part of Kontron Technology India with respect to technical processes described in the manual or any product characteristics set out in the manual. Kontron Technology India does not accept any liability for any printing errors or other inaccuracies in the manual unless it can be proven that Kontron Technology India is aware of such errors or inaccuracies or that Kontron Technology India is unaware of these as a result of gross negligence and Kontron Technology India has failed to eliminate these errors or inaccuracies for this reason. Kontron Technology India expressly informs the user that this manual only contains a general description of technical processes and instructions which may not be applicable in every individual case. In cases of doubt, please contact Kontron Technology India.





This manual is protected by copyright. All rights are reserved by Kontron Technology India. Copies of all or part of this manual or translations into a different language may only be made with the prior written consent of Kontron Technology India. Kontron Technology India points out that the information contained in this manual is constantly being updated in line with the technical alterations and improvements made by Kontron Technology India to the products and thus this manual only reflects the technical status of the products by Kontron Technology India at the time of printing.

© 2013 by Kontron Technology India

Printing and duplication, even of sections, is only permissible with the express approval of

Kontron Technology India Pvt Ltd
#425 , 2nd Main Road,
Kasturinagar,
East of N.G.E.F.,
Bangalore - 560 043
INDIA

2.1. Symbols used in this Manual

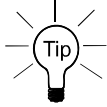
Symbol	Meaning
	This symbol indicates the danger of injury to the user or the risk of damage to the product if the corresponding warning notices are not observed.
	This symbol indicates that the product or parts thereof may be damaged if the corresponding warning notices are not observed.
	This symbol indicates general information about the product and the user manual.
	This symbol indicates detail information about the specific product configuration.
	This symbol precedes helpful hints and tips for daily use.

3. Important Instructions

This manual provides important information required for the proper operation of the VRack 4U platform!

This chapter contains instructions which must be observed when working with the VRack 4U platform.

3.1. Warranty Note

Due to their limited service life, parts which by their nature are subject to a particularly high degree of wear (wearing parts) are excluded from the warranty beyond that provided by law. This applies to batteries, for example.

3.2. Exclusion of Accident Liability Obligation

Kontron Technology India shall be exempted from the statutory accident liability obligation if the user fails to observe the "General Safety Instructions for IT Equipment" chapter, the hints in this manual or eventually the warning signs label on the device.

3.3. Liability Limitation / Exemption from the Warranty Obligation

In the event of damage to the device caused by failure to observe the "General Safety Instructions for IT Equipment" chapter, the hints in this manual or eventually the warning signs label on the device, Kontron Technology India shall not be required to honor the warranty even during the warranty period and shall be exempted from the statutory accident liability obligation.

4. General Safety Instructions for IT Equipment



Caution:

Energy hazards > 240 VA are present inside the chassis!

Activities such as system expansion with expansion cards, or maintenance have to be carried-out by qualified personnel familiar with the associated dangers!

The installation instructions for the VRack 4U platform is the responsibility of the distributor.

When used as intended the VRack 4U platform is to operate only closed and locked.

Only when the cover is properly installed, secured with the knurled screws on the rear and the cover fastening screw on the front, and the access panel is locked with the key, it is ensured that the user doesn't have access to the internal parts of the VRack 4U platform, loaded with hazardous energy.

Please read this passage carefully and take careful note of the instructions, which have been compiled for your safety and to ensure to apply in accordance with intended regulations. If the following general safety instructions are not observed, it could lead to injuries to the operator and/or damage of the VRack 4U; in cases of non-observance of the instructions Kontron is exempt from accident liability, this also applies during the warranty period.

The VRack 4U has been built and tested according to the basic safety requirements for low voltage (LVD) applications and has left the manufacturer in safety-related, flawless condition. To maintain this condition and to also ensure safe operation, the operator must not only observe the correct operating conditions for the VRack 4U but also the following general safety instructions:

- The VRack 4U must be used as specified in the documentation, in which the instructions for safety for the product and for the service person/operator are described. These contain guidelines for setting up, installation and assembly, maintenance, transport or storage.
- The on-site electrical installation must meet the requirements of the country's specific local regulations.
- If a power cable comes with the VRack 4U, only this cable should be used. Do not use an extension cable to connect the VRack 4U.
- To guarantee that sufficient air circulation is available to cool the VRack 4U, please ensure that the ventilation openings are not covered or blocked. If a filter mat is provided, this should be cleaned regularly. Do not place the system close to heat sources or damp places. Make sure the system is well ventilated.
- Only devices or parts which fulfill the requirements of SELV circuits (Safety Extra Low Voltage) as stipulated by IEC 60950-1 may be connected to the available interfaces.
- Before opening the device, make sure that the device is disconnected from the mains.
- Switching off the device by its power button does not disconnect it from the mains. Complete disconnection is only possible if the power cable is removed from the wall plug or from the device. Ensure that there is free and easy access to enable disconnection.
- The device may only be opened for the insertion or removal of add-on cards (depending on the configuration of the system). This may only be carried out by qualified service persons for this area.
- If extensions are being carried out, the following must be observed:
 - all effective legal regulations and all technical data are adhered to
 - the power consumption of any add-on card does not exceed the specified limitations
 - the current consumption of the system does not exceed the value stated on the type label of VRack 4U.
- Only original accessories that have been approved by Kontron can be used.
- Please note: safe operation is no longer possible when any of the following applies:
 - the device has visible damages or
 - the device is no longer functioning
 In this case the device must be switched off and it must be ensured that the device can no longer be operated.

Additional safety instructions for DC power supply circuits

- ❑ To guarantee safe operation of devices with DC power supply voltages larger than 60 volts DC or a power consumption larger than 240 VA, please observe that:
 - the device is set up, installed and operated in a room or enclosure marked with "RESTRICTED ACCESS", if there are no safety messages on VRack 4U system as safety signs and labels on the device itself.
 - no cables or parts without insulation in electrical circuits with dangerous voltage or power should be touched directly or indirectly
 - a reliable protective earthing connection is provided
 - a suitable, easily accessible disconnecting device is used in the application (e.g. overcurrent protective device), if the device itself is not disconnect able
 - a disconnect device, if provided in or as part of the equipment, shall disconnect both poles simultaneously
 - interconnecting power circuits of different devices causes no electrical hazards
- ❑ A sufficient dimensioning of the power cable wires must be selected – according to the maximum electrical specifications on the type label as stipulated by EN60950-1 or VDE0100 or EN60204 or UL508 regulations.
- ❑ The devices do not generally fulfill the requirements for "centralized DC power systems" (UL 60950-1, Annex NAB; D2) and therefore may not be connected to such devices!

4.1. Operation of Laser Source Devices

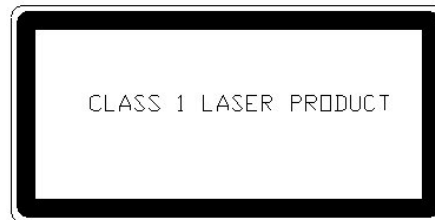

Fig. 1: Laser radiation warning label

The optional DVD drives contain light-emitting diodes (classified in accordance with IEC 825-1:1993, EN 60825:1997: LASER CLASS 1 and therefore must not be opened.

If the enclosure of such a drive is opened, invisible laser radiation is emitted. Do not allow yourself to be exposed to this radiation.

The laser system meets the code of Federal Regulations 21 CFR, 1040 for the USA and the Canadian Radiation Emitting Devices Act, REDR C 1370.



4.2. Electrostatic Discharge (ESD)

A sudden discharge of electrostatic electricity can destroy static-sensitive devices or micro-circuitry. Proper packaging and grounding techniques are necessary precautions to prevent damage. Always take the following precautions:

1. Transport boards in static-safe containers such as boxes or bags.
2. Keep electrostatic sensitive parts in their containers until they arrive at the ESD-safe workplace.
3. Always be properly grounded when touching a sensitive board, component, or assembly.
4. Store electrostatic-sensitive boards in protective packaging or on antistatic mats.

4.2.1. Grounding Methods

The following measures help to avoid electrostatic damages to the device:

1. Cover workstations with approved antistatic material. Always wear a wrist strap connected to workplace as well as properly grounded tools and equipment.
2. Use anti-static mats, heel straps, or air ionizers to give added protection.
3. Always handle electrostatic sensitive components by their edge or by their casing.
4. Avoid contact with pins, leads, or circuitry.
5. Turn off power and input signals before inserting and removing connectors or connecting test equipment.
6. Keep work area free of non-conductive materials such as ordinary plastic assembly aids and styrofoam.
7. Use field service tools such as cutters, screwdrivers, and vacuum cleaners which are conductive.
8. Always place drives and boards PCB-assembly-side down on the foam.

4.3. Instructions for the Lithium Battery

The installed motherboard or SBC (Single Board Computer) is equipped with a Lithium battery. When replacing the lithium battery, please follow the corresponding instructions in the chapter 10.2 "Replacing the Lithium Battery".



Caution

Danger of explosion when replacing with wrong type of battery. Replace only with the same or equivalent type recommended by the manufacturer. The lithium battery type must be UL recognized.



Do not dispose of lithium batteries in general trash collection. Dispose of the battery according to the local regulations dealing with the disposal of these special materials, (e.g. to the collecting points for dispose of batteries).

5. Electromagnetic Compatibility (Class A Device)

5.1. Electromagnetic Compatibility (EU)

This product is intended only for use in industrial areas. The most recent version of the EMC guidelines (EMC Directive 2004/108/EC) and/or the German EMC laws apply. If the user modifies and/or adds to the equipment (e.g. installation of add-on cards) the prerequisites for the CE conformity declaration (safety requirements) may no longer apply.

Warning!

This is a class A product. In domestic environment this product may cause radio interference in which case the user may be required to take adequate measures.

5.2. FCC Statement (USA)

This equipment has been tested and found to comply with the limits for a Class A digital device, pursuant to Part 15 of the FCC Rules. These limits are designed to provide reasonable protection against harmful interference when the equipment is operated in commercial environment. This equipment generates, uses, and can radiate radio frequency energy and, if not installed and used in accordance with the instruction manual, may cause harmful interference to radio communications. Operation of this equipment in residential area is likely to cause harmful interference in which case the user will be required to correct the interference at his own expense.

5.3. EMC Compliance (Canada)

The method of compliance is self-declaration to Canadian standard ICES-003:

(English): This Class A digital apparatus complies with the Canadian ICES-003.

(French): Cet appareil numérique de la class A est conforme à la norme NMB-003 du Canada.

6. Scope of Delivery

- VRack 4U platform (system configuration ordered)
- Two keys for the access panel lock
- Rubber feet (self-adhesive)
- AC power cord

Optional Parts:

- Slide rails

6.1. Type Label and Product Identification

The type label (product designation, serial number) and the inspection status label of your VRack 4U platform are located on the right side of the device.

System Type	Product Designation	Product Identification
VRack 4U	VRack 4U xxxxxxxx-y	<p>VRack 4U = System type</p> <p>The "xxxxxxx" group is replaced by up to a max. 8-digit combination of numbers, letter or space, and represents the installed CPU board</p> <p>The "y" is replaced by a single letter (A through Z) representing the power supply installed into the system.</p>

Note for power supplies (PSU):

A: corresponds to the systems with a 400W wide range AC power supply



Fig. 2: VRack 4U - configuration with DVD drive and internal HDD



Fig. 3: VRack 4U - configuration with DVD and DA435 drives

7. Product Description

The VRack 4U platform expands the Kontron 4U platform line. VRack 4U is a scalable 4U (19") platform, that can be equipped with different motherboards, supporting various system configurations (refer to "VRack 4U Systems - Configuration Guides" on our website). The flexible customer-specific hardware system configuration and the robust construction with excellent mechanical stability of the VRack 4U platform offer the superior qualities of a computer designed for operation in harsh industrial environment.

The VRack 4U platform is designed to be installed in 19" racks. It may be used as desktop version.



Fig. 4: VRack 4U - side view with opened access panel

The system can be equipped with up to five drive bays (depending on the system configuration ordered):

- D1, D2 and D3:** three 5.25" front accessible drive bays
- D4 and D5:** two internal 3.5" drive bay
- D6:** 3.5" front accessible drive bay

The power button of the VRack 4U platform is located on the front side behind the front access panel. The LED indicators are located on the front side and consist of a "power LED" and a "hard disk activity LED".

Two of the system fans are installed at the front side of the unit.

The washable filter mat which protects your system against dust and dirt is located on the front side of the system. This filter mat can be replaced during operation.

The type label is attached to the right side of the device.



The VRack 4U platform may be operated in horizontal position.

When powering on the VRack 4U system, make sure that the air intake and exhaust openings are not obstructed by objects.

For using as desktop unit, four rubber feet are included in the accessory. To attach the rubber feet, please follow the instructions in chapter 8.1 "Attaching the Rubber Feet".

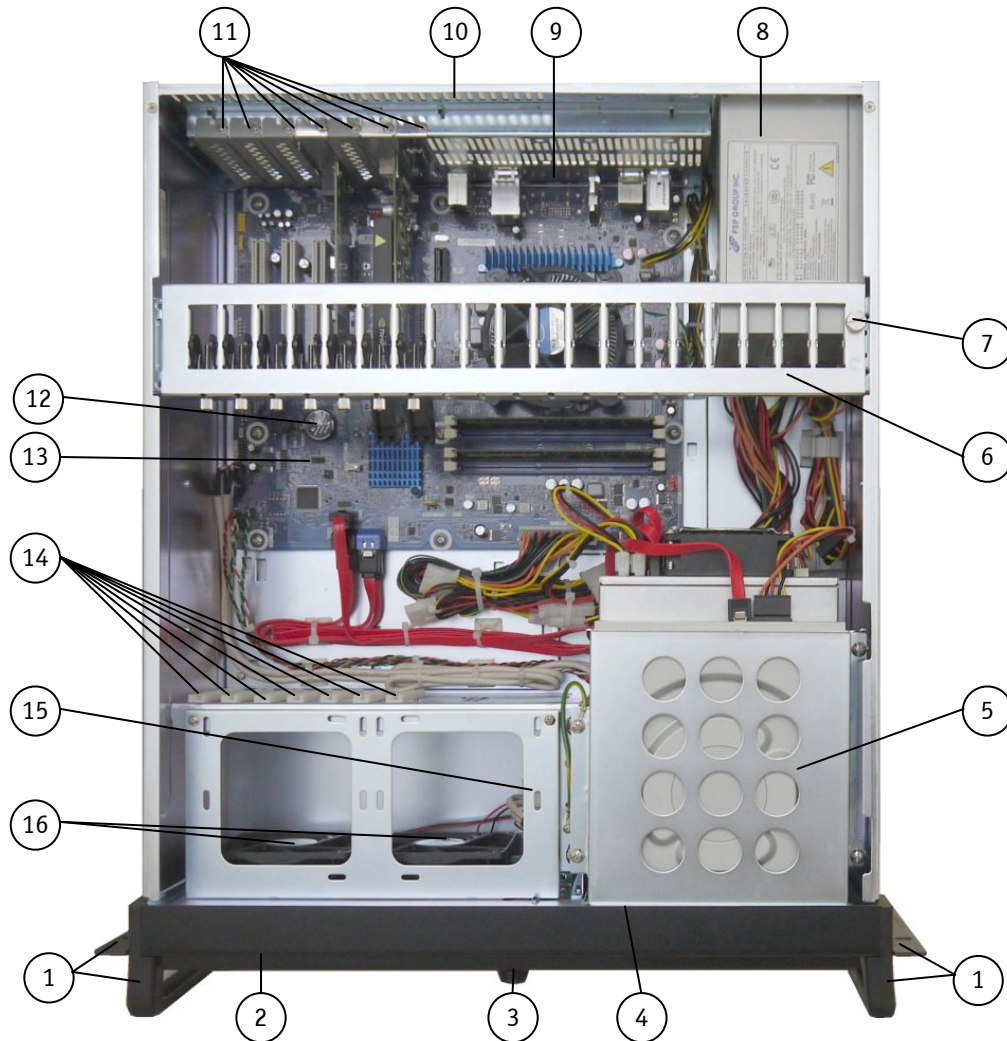

Fig. 5: VRack 4U, opened (shown as VRack DZ77-A with external accessible drives only)

- | | | | |
|---|---|----|---|
| 1 | 19" rack bracket with handle | 9 | External interfaces of the motherboard |
| 2 | Front access panel | 10 | Exhaust openings on the rear side |
| 3 | Access panel lock | 11 | Slots for expansion cards |
| 4 | Cover retaining plate on the front side | 12 | Lithium Battery (CMOS) |
| 5 | D1, D2, D3, D6: front accessible drives (mounted on top of each other in a drive cage) | 13 | Motherboard |
| 6 | Card hold down bracket (for short expansion cards) | 14 | Card guides (for full-length cards) |
| 7 | Fastening screw for the card hold down bracket (internal accessible) | 15 | Drive bracket for two internal 3.5" drive bay (D4, D5) (shown without installed internal HDDs) |
| 8 | AC power supply unit | 16 | System fans |

Note: for drive location, refer also Fig. 11.

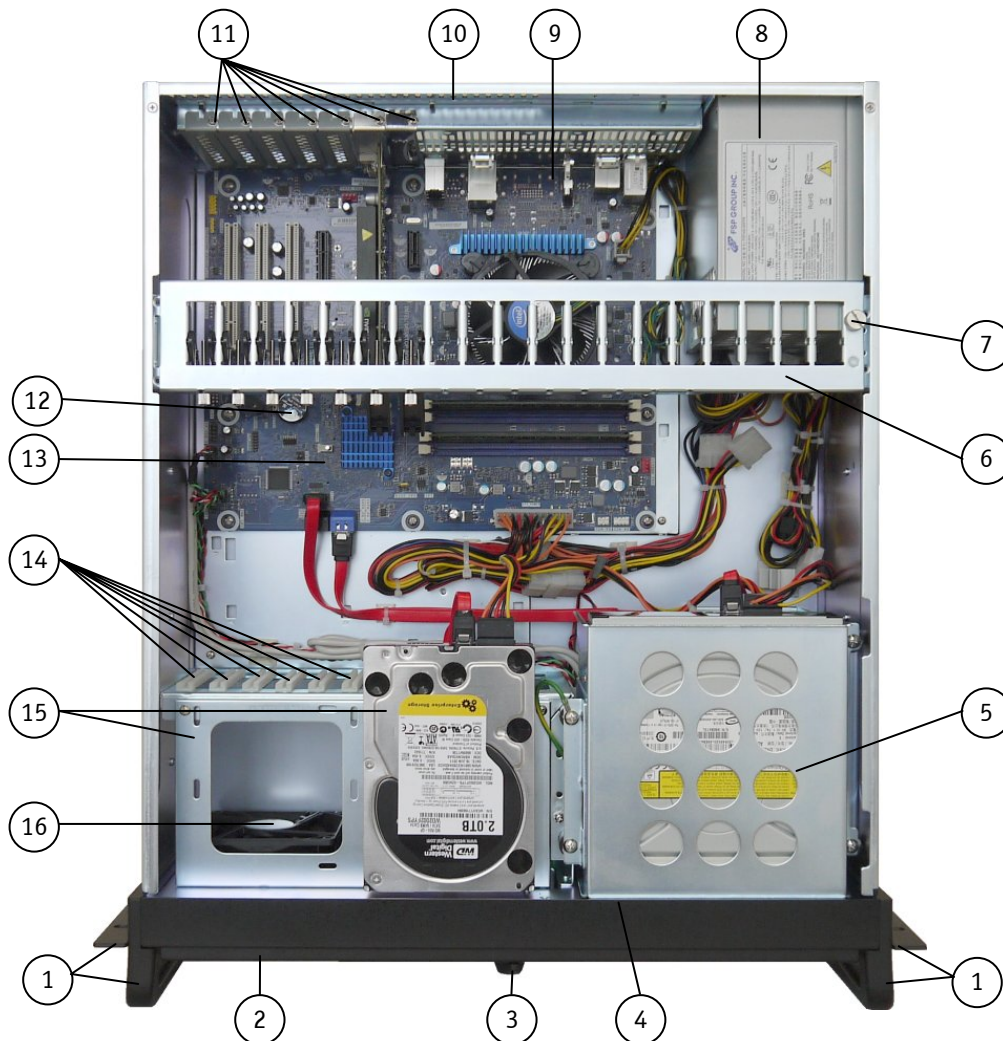

Fig. 6: VRack 4U opened (shown as VRack 4U DZ77-A with internal HDD and external accessible drive)

- | | | | |
|---|---|----|---|
| 1 | 19" rack bracket with handle | 9 | External interfaces of the motherboard |
| 2 | Front access panel | 10 | Exhaust openings on the rear side |
| 3 | Access panel lock | 11 | Slots for expansion cards |
| 4 | Cover retaining plate on the front side | 12 | Lithium Battery (CMOS) |
| 5 | D1, D2, D3, D6: front accessible drive bays (mounted on top of each other in a drive cage) | 13 | Motherboard |
| 6 | Card hold down bracket (for short expansion cards) | 14 | Card guides (for full-length cards) |
| 7 | Fastening screw for the card hold down bracket (internal accessible) | 15 | Drive bracket for two 3.5" drive bay (D4, D5) [shown with one installed 3.5" HDD (internal accessible only)] |
| 8 | AC power supply unit | 16 | System fans (only one of two is visible) |

Note: for drive location, refer also Fig. 11.

7.1. Front Side

Depending on the ordered system configuration, the VRack 4U platform will be delivered as rackmount or tower version.

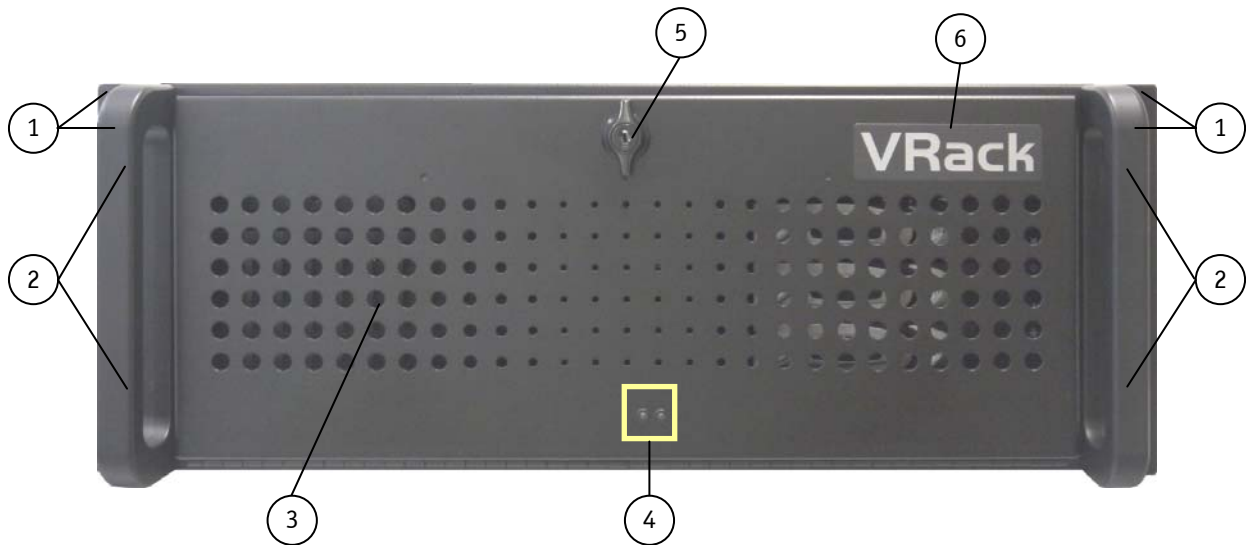

Fig. 7: Front side with closed front access panel

- | | |
|--|--|
| 1 19" handle bracket | 4 Light diffusers for the HDD LED and the power LED Kontron Logo |
| 2 Holes for mounting in 19" racks (not visible in the picture) | 5 Securing lock mechanism |
| 3 Air openings on the front access panel | 6 Product name |

The power button, the power and HDD LEDs, 2x USB interfaces, Reset, 1x filter mat holder and the external accessible drives are located at the front side of the VRack 4U platform behind the access panel.

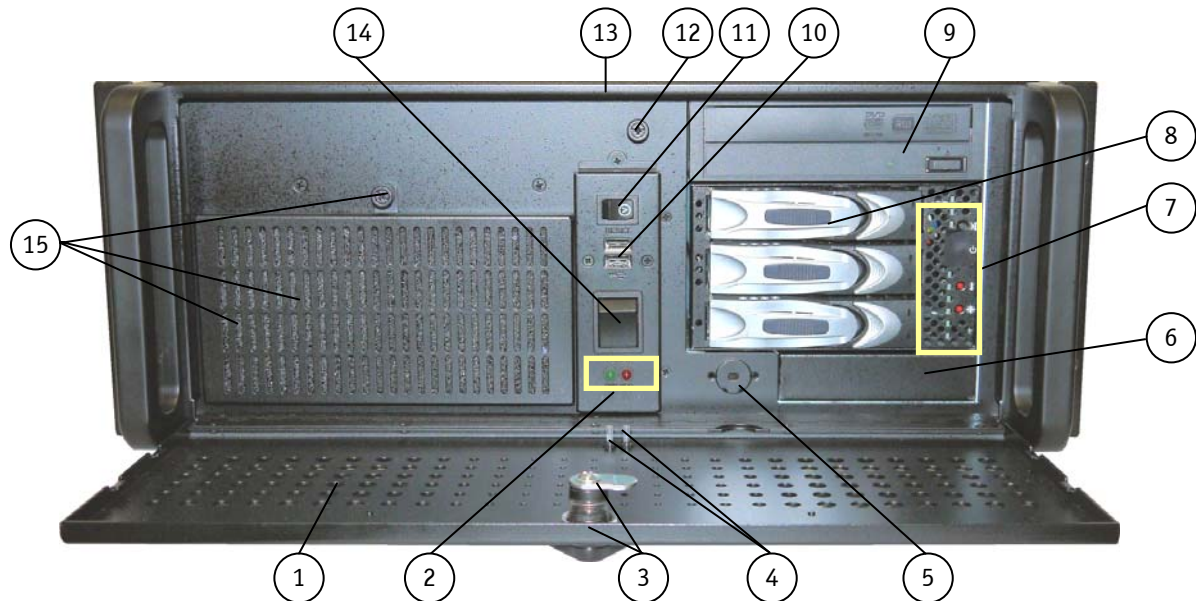

Fig. 8: Front side with opened access panel

Legend for Fig. 8:

- | | |
|---|--|
| 1 Access panel | 9 D1: front accessible 5.25" drive bay (with installed DVD drive) |
| 2 Indicators (Power LED, HDD activity LED) | 10 2x USB 2.0 |
| 3 Securing lock mechanism (two keys are provided) | 11 Reset button |
| 4 Light diffusers for the HDD LED and the power LED | 12 Cover fastening screw on the front side |
| 5 Circular cut-out for optional (customer-specific) on board interface routed to the rear panel | 13 Top chassis bracket (is used also to lock the access panel and to secure the cover) |
| 6 Covering plate | 14 Power button |
| 7 Controls (LED-indicators and power button of the installed D2+D3 drives (as KISS DA335)) | 15 Filter mat and filter mat holder with knurled screw |
| 8 D2+D3: front accessible 5.25" drive bays (with installed KISS DA335) | |

7.1.1. Interfaces and Controls on the Front Side

7.1.1.1. USB Interfaces

The VRack 4U platform is equipped with two USB interfaces on the front side (see Fig. 8, pos. 4 and Fig. 9, pos. 2). You can connect various USB devices to these two USB 2.0 interface connectors.

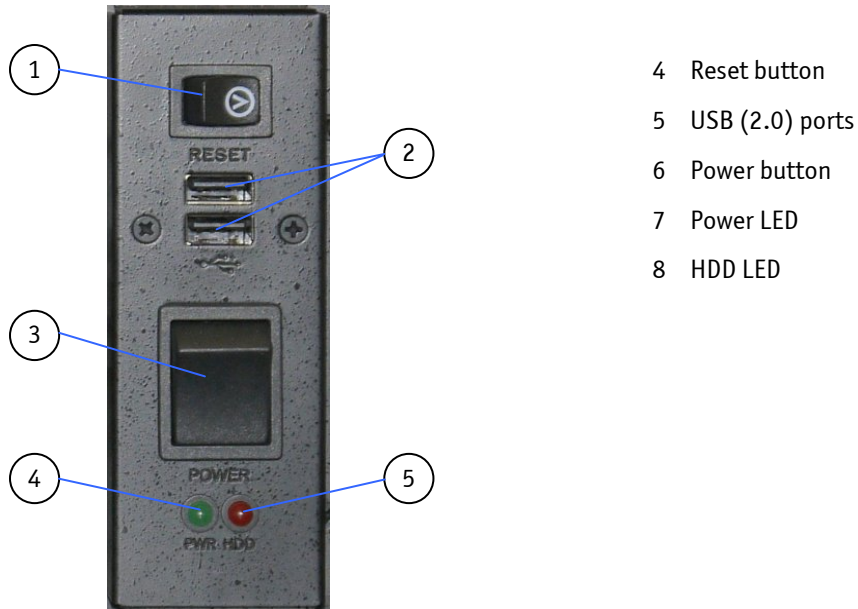

Fig. 9: Controls, indicators and USB ports at the front side



If USB devices are connected to the USB ports on the front of the device, the front access panel cannot be closed and locked.

7.1.2. Controls and Indicators

7.1.2.1. Power Button

The power button (see Fig. 8, pos. 15 and Fig. 9, pos. 3) is located on the front side of the system, behind the front access panel. Press this button to turn the system on or off.



Please observe the setting options for the power in the BIOS-Setup.

The standard configurations of VRack 4U platform are delivered with the default setting.



Even when the system is turned off via the power button (Fig. 8, pos. 3) there is still a standby-voltage of 5 VSb on the motherboard.

Warning!

The unit is completely disconnected from the mains, only when the ON/OFF switch of the PSU is set to OFF or when the power cord is disconnected either from the mains or the unit. Therefore, the power cord and its connectors must always remain easily accessible.

7.1.2.2. Power LED and HDD Activity LED

The indicators (see Fig. 8, pos. 2) of the VRack 4U platform are located on the front side, behind the front access panel.



- 1 Power LED
- 2 HDD activity LED

Fig. 10: LED indicators on the front side

Power LED (green)	<p>This LED (Fig. 10, pos. 1) lights up green when the system is turned on by pressing the power button.</p> <p>Prerequisite: The system has to be connected to an appropriate AC power source. For system configuration with AC PSU, the power ON/OFF switch of the AC PSU must be set to ON.</p>
HDD LED (orange)	<p>This LED (Fig. 10, pos. 2) lights up during hard disk activity.</p>

7.1.2.3. Reset-button

If your system no longer reacts, you have to restart the VRack 4U platform. Press the reset button to restart your system.

7.1.3. Front Access Panel

The securing lock mechanism (Fig. 7, pos. 3) located at the access panel allows you, if required, to protect your system from unauthorized use. When the access panel is locked, the cover of the VRack 4U system can not be removed, and the drives and the power and reset button are not accessible.



The key should be kept somewhere where it is not accessible to unauthorized persons.



If USB devices are connected to the USB ports on the front of the device, the front access panel cannot be closed and locked.

7.1.4. Cover Fastening Screw on the Front Side

The cover fastening screw (Fig. 8 pos. 12) secures the cover to the chassis on the front side.



To remove the cover of the VRack 4U platform, the knurled screw (Fig. 8 pos. 12) on the front side has to be loosened and the three mounting bolts (Fig. 12, pos. 11) on the rear side of the cover must be pulled out (by horizontal movement of the cover).

7.1.5. Filter Mat and Filter Mat Holder

The filter mat and the filter mat holder (Fig. 8, pos. 15) are located behind the air holes of the front access panel (Fig. 7, pos. 3). The filter mat holder is fastened to the front side panel of the VRack 4U via a knurled screw and two positioning plates. A filter mat is inserted in the filter mat holder. This filter mat protects your system against dust and dirt (see chapter 10.1 "Cleaning the Filter Mat").

7.1.6. Drive Bays

Depending on the ordered system configuration, the system can be equipped with up to six drives on the front side (see Fig. 8, pos. 6, 8, 9):

Drive Bay	Description
D1	Externally accessible 5.25" drive bay (shown with a DVD drive installed)
D2	Externally accessible 5.25" drive bay
D3	Externally accessible 5.25" drive bay
D4	One internal drive bay for a 3.5" SATA HDD
D5	One internal drive bay for a 3.5" SATA HDD
D6	One external accessible 3.5" drive bay



For VRack 4U system configurations with a disk subsystem with three HDDs (DA335), two 5.25" drive bays are occupied by this subsystem with removable HDDs (D2 and D3 in Fig. 8).

For VRack 4U system configurations with a disk subsystem with four HDDs (DA435) or five HDDs (DA535), three 5.25" drive bays are occupied by this subsystem with removable HDDs (D1, D2 and D3 in Fig. 8).

For customer-specific versions and system configurations, please refer to the corresponding "VRack 4U Systems - Configuration Guides" for VRack 4U on our website www.kontron.com.



Fig. 11: Front accessible drive bays (e.g. D1 equipped with a DVD drive)

7.2. Rear Side

Depending on the VRack 4U platform configuration ordered, the rear panel will have the external interfaces of the installed motherboard, any additional interfaces (customer-specific), the power supply unit and the air exhaust openings.



The positioning and number of the VRack 4U platform interfaces may vary depending on the system configuration ordered.

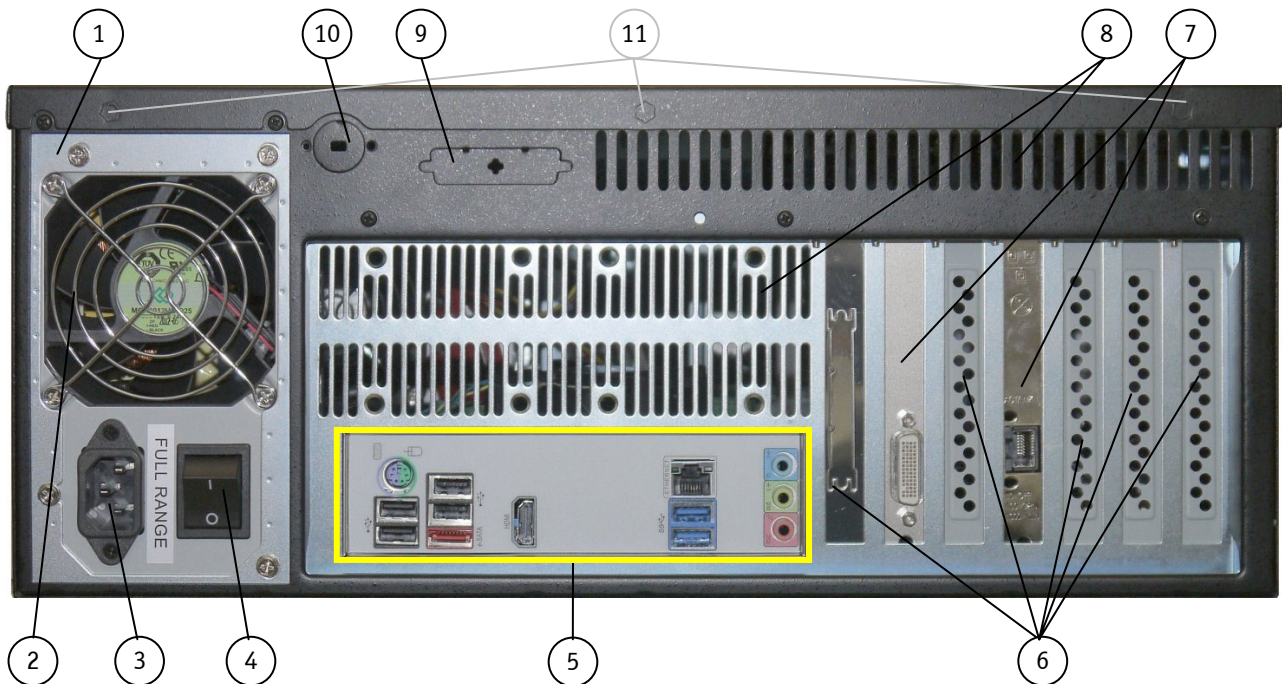

Fig. 12: Rear side of a VRack 4U platform (shown as VRack DZ77-A; the expansion cards are as example only)

- | | |
|---|--|
| 1 AC power supply unit (PSU) | 8 Air exhaust openings |
| 2 Power supply fan | 9 Cut-outs for optional (customer-specific) interfaces routed to the rear panel (9-pin D-SUB type connector) |
| 3 AC input connector | 10 Circular cut-out for optional (customer-specific) on board interface routed to the rear panel |
| 4 "On/Off" switch of the power supply unit | 11 3x mounting bolt to fix the cover on the rear side to the device chassis |
| 5 External interfaces of the motherboard | |
| 6 Free expansion card slots | |
| 7 Slot brackets of installed expansion cards (not included in the standard configuration) | |

7.2.1. Power Supply

The power supply (Fig. 12, pos. 1) is located on the rear side of the VRack 4U platform.

The power supply version and the corresponding nominal voltage range can be found on the type label on the right side of the system.

7.2.2. External Interfaces of the DZ77-SL-50K Motherboard



A detailed ports description can be found in the documentation of the installed motherboard. You can download the corresponding documentation from the web site www.intel.com/products/motherboards by selecting the product name.

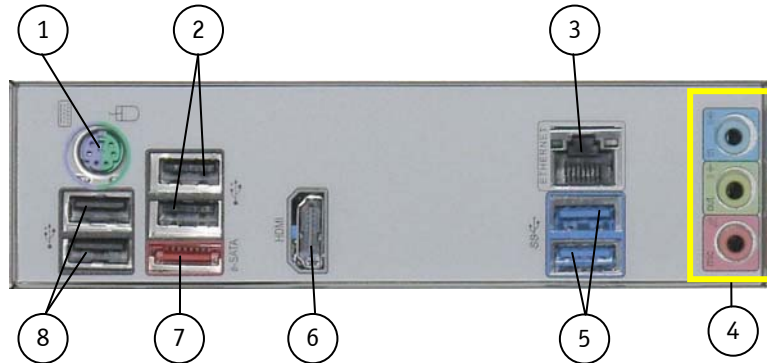

Fig. 13: External ports of the Intel® DZ77 motherboard

- | | |
|--|----------------------------|
| 1 Combined PS/2 Keyboard&Mouse port (purple/green) | 5 2x USB(3.0) ports (blue) |
| 2 2x USB (2.0) | 6 HDMI Video connector |
| 3 1x Ethernet ports (RJ45), (10/100/1000 Mbps) | 7 eSATA port |
| 4 Audio connectors [Intel® (5.1+2)High Definition] | 8 2x USB (2.0) |

7.2.3. External Interfaces of the KTQ45/ATXE Motherboard



A detailed ports description can be found in the manual of the installed motherboard. You can download the corresponding manual from our web site www.kontron.com by selecting the product name.

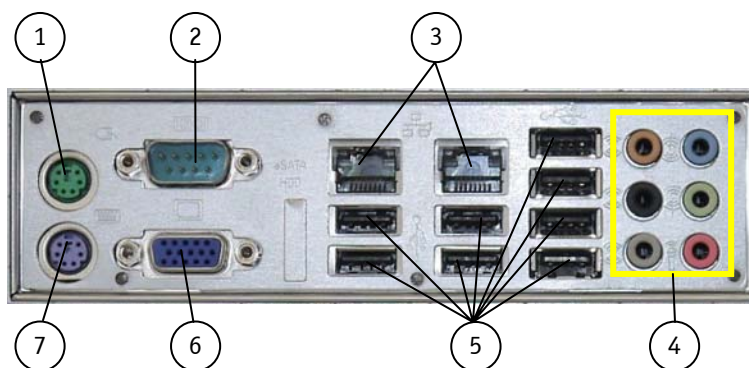

Fig. 14: External ports of the KTQ45/ATXE motherboard

- | | |
|---|--------------------------------|
| 9 PS/2 mouse port (green) | 12 Audio connectors (6.1) |
| 10 Serial port (RS232) | 13 6x USB(2.0) ports |
| 11 2x Ethernet ports (RJ45), (10/100/1000 Mbps) | 14 VGA port |
| | 15 PS/2 keyboard port (purple) |

7.3. Side View

Five M4 metric tapped holes are available at the left and right side of the unit (Fig. 15, pos. 2). These can be used in order to attach slide rails [not included; see chapter 11 “Slide Rails (Option)”] to the VRack 4U platform for system installation into a 19” industrial cabinet.

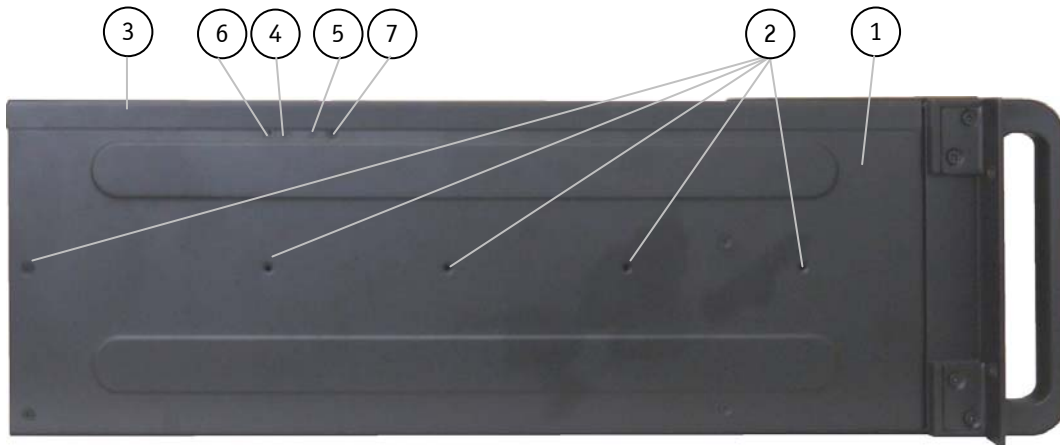

Fig. 15: VRack 4U platform – side view

- | | |
|---|---|
| <ul style="list-style-type: none"> 1 Left side view of a VRack 4U platform 2 5x M4 tapped holes (on both sides) 3 Cover 4 Internal bolt for the card hold down bracket for long expansion cards (full-length) | <ul style="list-style-type: none"> 5 Externally accessible screw (countersunk screw M3x6) for fastening the card hold down bracket for long expansion cards (full-length) 6 Internal bolt for the card hold down bracket for short expansion cards (half-length) 7 Externally accessible screw (countersunk screw M3x6) for fastening the card hold down bracket for short expansion cards (half-length) |
|---|---|

7.4. Fans

The two system fans (Fig. 5 and Fig. 6, pos. 16) are located in front of the VRack 4U platform. A reliable air circulation for optimal active cooling of the platform is ensured.



The operation of the VRack 4U platform is permitted only with functional fans. Defective components may only be replaced by Kontron original spare parts.

8. Assembly, Disassembly

8.1. Attaching the Rubber Feet

The rubber feet can be used for the desktop version of the system.

To attach the rubber feet to the bottom side of the chassis, please perform the following steps:

1. Turn your system off and disconnect it from the main power supply.
2. Make sure that all cards are secured into unit and that the system cover is installed and secured.
3. Turn the system upside down.
4. Remove the protective film from the self adhesive rubber feet.
5. Attach the self adhesive rubber feet to the bottom side of the chassis.

8.2. Cover

The cover will be fixed to the chassis using the fixing brackets at the front side of the cover (Fig. 16, pos.3), three fixing bolts at the rear side of the cover (Fig. 16, pos.6) and the cover fastening screw (Fig. 8, pos. 12) at the front side of the VRack 4U platform.

When closing the cover, make sure that the fixing bolts (Fig. 16, pos. 6) are inserted properly into the corresponding retaining holes of the chassis on the rear side. The centering bracket (Fig. 16, pos. 3) and the front cover fastening screw (Fig. 8, pos. 12) secure the cover on the front side.



Fig. 16: Inside of the cover with fixing brackets

- | | |
|--|-----------------------------------|
| 1 Inside of the cover | 3 Fixing bolts (on the rear side) |
| 2 Angulated centering bracket with tapped hole (on the front side) | |

8.3. Accessing Internal Components

This chapter contains important information on working safely with internal components. Please follow these instructions when handling cards or replacing system fans.

8.3.1. Installing/Removing the Expansion Cards



When you install (or remove) expansion cards please consider the corresponding safety instruction included in chapter 4 "General Safety Instructions for IT Equipment".

Activities such as working inside the system or handling the expansion cards have to be carried-out by qualified personnel for this area.

Before removing the device cover, ensure that your system is switched off and disconnected from the mains power supply.

Caution:

Energy hazards > 240 VA are present inside the chassis!

Activities such as system expansion with expansion cards, or maintenance have to be carried-out by qualified personnel familiar with the associated dangers!



Please follow the safety instructions for components that are sensitive to electrostatic discharge (ESD). Failure to observe this warning notice can result in damage to the device.



Please consult the documentation provided by the manufacturer of the expansion card for instructions before attempting to install/remove an expansion card into/from your system.

To install or remove an expansion card, perform the following steps:

1. Turn your system off and disconnect it from the AC power supply.
2. Loosen the cover fastening screw on the front side (Fig. 8, pos. 12) that secures the cover on the front side.



Fig. 17: Loosening the knurled cover fastening screw on the front side



Fig. 18: Pull out the cover with the fixing bolts on the rear

3. Pull the cover out a little bit (Fig. 18, step 1) to release the cover centering bracket at the front and the fixing bolts on the rear side.
4. Lift the cover up (on the rear side, Fig. 18, step 2) and remove it (Fig. 19).



Fig. 19: VRack with removed cover

5. In order to re-assemble the system, follow the steps in reversed order. Close the VRack 4U platform and secure the cover with the captive knurled screw.

8.4. Installation in a 19" Industrial Cabinet

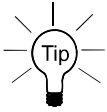

Expansion card installation should be performed before installing the VRack 4U system into a 19" industrial cabinet.

Please consider the instructions described in the section 8.3 "Accessing Internal Components".

Before closing the industrial cabinet, you must connect your peripherals to the corresponding system ports.

For VRack 4U versions and system configurations, please refer to the corresponding "VRack 4U Systems - Configuration Guides" on our website www.kontron.com. More information and technical data can be found in the corresponding motherboard manual, depending on the system configuration ordered).

You can download the manual from our web site at www.kontron.com by selecting the product.



In order to setting-up installing / removing the VRack 4U platform into/from a 19" industrial cabinet, please observe the instructions described in this manual.

Please consider the corresponding safety instruction included in chapter 4 "General Safety Instructions for IT Equipment".

The system has to be mounted and installed only by qualified personnel for this area familiar with the associated dangers.

Ensure there is sufficient air circulation around the device when installing the VRack 4U platform.

The openings for air intake and exhaust on the device must not be obstructed by objects.

Leave at least 5 cm (1.969 ") of free space in front and behind the VRack 4U platform to prevent the device from possibly overheating.

The VRack 4U platform should be installed into a 19" industrial cabinet by use of slide rails (not included).

The 19" industrial cabinet must stand firmly in place. You can improve its stability by placing the components into it from the bottom up. Heavy components should be placed down below.

If further stabilization is necessary, then bolt the 19" industrial cabinet to the floor or anchor it on the wall.

The voltage feeds must not be overloaded.

Adjust the cabling and the external overcharge protection to correspond with the electrical data indicated on the type label.

The type label is located on right side of the unit.

9. Starting Up



Please consider the Hints included in the chapter 4 “General Safety Instructions for IT Equipment”.

When used as intended the VRack 4U platform is to operate only closed and locked.

Only when the cover is properly installed, secured with the cover fastening screw on the front, and the access panel is locked with the key, it is ensured that the user doesn't have access to the internal parts of the VRack 4U platform, loaded with hazardous energy.

The rated voltage range of the AC mains must agree with the voltage value on the type label.



Please observe the settings for the option “AC Power Loss” in the BIOS Setup.

The standard configurations of VRack 4U platform are delivered with the default setting.

9.1. AC Power Connection

The AC input connector is located at the rear side of the VRack 4U system.



AC input connector

Fig. 20: VRack 4U, rear side (shown as VRack 4U DZ77-A)

To connect the VRack 4U platform to an AC power supply, perform the following steps:

1. Connect the AC power cord to the AC input connector.
2. Connect the other end of the AC power cord to a corresponding mains outlet.



Make sure that the power supply (power outlet) is properly grounded and that the power cord is in perfect condition without any visible damage. An ungrounded power supply is not permissible.

9.2. Operating System and Hardware Component Drivers

The VRack 4U system can optionally be supplied with or without a pre- installed operating system.

If you have ordered your system with a pre- installed operating system, all drivers are installed, corresponding to the ordered computer configuration (optional hardware components). Your computer is fully operational, when you switch it on for the first time. Please observe the information below.



Important information for using the pre-installed “WINDOWS 7 ULTIMATE FOR EMBEDDED SYSTEMS” or “WINDOWS 7 PROFESSIONAL FOR EMBEDDED SYSTEMS” operating systems:

The terms and condition for using the pre-installed operating systems are defined in the document “MICROSOFT SOFTWARE LICENSE TERMS”. “This end use license agreement should be read before using the MICROSOFT software. By using the MICROSOFT software, you signify that you have read the “MICROSOFT SOFTWARE LICENSE TERMS” and accept its terms.”

The document “MICROSOFT SOFTWARE LICENSE TERMS” can be downloaded from our web site www.kontron.com by selecting the product name/tab Downloads/Windows.

If you have ordered VRack 4U without a pre-installed operating system, you will need to install the operating system and the appropriate drivers for the system configuration you have ordered (optional hardware components) yourself.



You can download the relevant drivers for the installed hardware from our web site at www.kontron.com by selecting the product.

Consider the manufacturer’s specifications for the operating system and the integrated hardware components.

10. Maintenance and Prevention

Equipment from Kontron Technology India requires only minimum servicing and maintenance for problem-free operation.

- ❑ For light soiling, clean the VRack 4U with a dry cloth.
- ❑ Stubborn dirt should be removed using a mild detergent and a soft cloth.
- ❑ Clean the filter mat regularly (see chapter 10.1 “Cleaning the Filter Mat”).

10.1. Cleaning the Filter Mat

The filter mat (Fig. 21, pos. 2, Fig. 25) is inserted in the filter mat holder (Fig. 21, pos. 3, Fig. 23) at the front side in front of the fans (Fig. 22, pos. 2). The soiling of the filter mat is caused by the pollution of the operating environment. A heavily soiled filter mat can cause excessive heating of the device. For this reason we recommend to clean the filter mat as often as necessary. The filter mat can be changed during operation of the system.

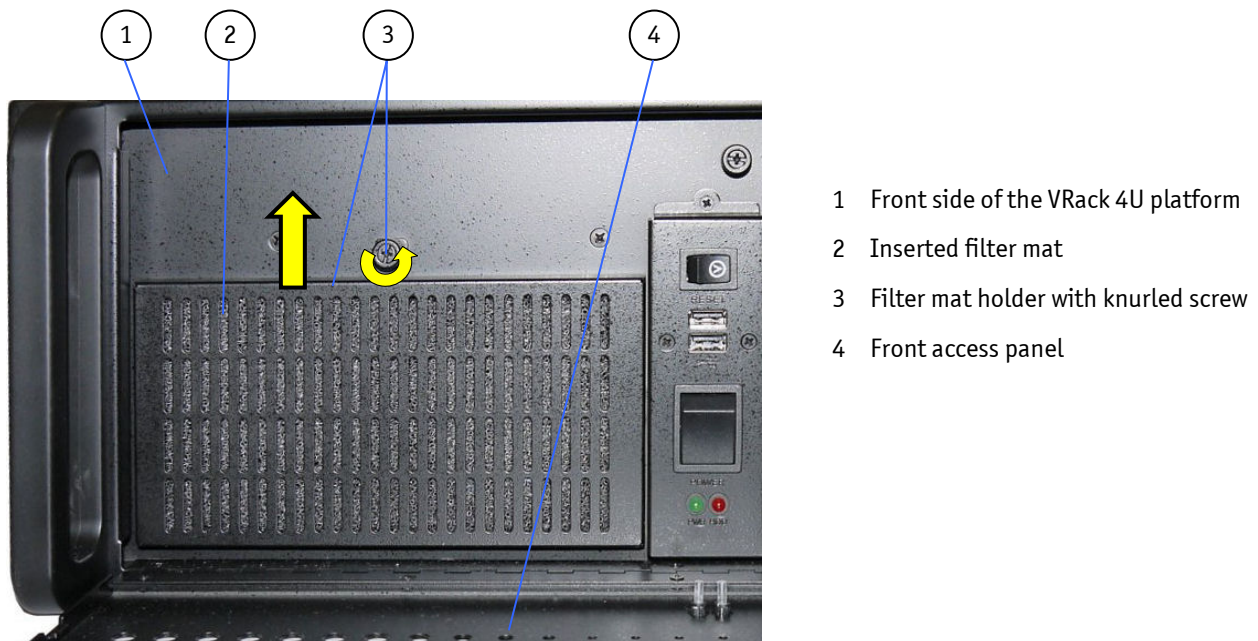

Fig. 21: Detail: Filter mat holder on the front side of the VRack 4U platform

To replace the filter mat, proceed as follows:

1. Open the front access panel (Fig. 21, pos. 4).
2. Loosen the knurled screw that secures the filter mat holder to the fan slide-in module (Fig. 21, pos. 3 and Fig. 23, pos. 5).
3. Pull the filter mat holder out of the positioning holes (Fig. 22, pos. 3) into the marked direction (see Fig. 21) and lift it off.
4. Remove the soiled filter mat (Fig. 21, pos. 2 and Fig. 25).
5. Clean the filter mat as follows:
 - ❑ Rinse in water (up to approx. 40°C; possibly with the addition of a standard mild detergent).
 - ❑ It is also possible to beat the filter pad, to vacuum it or blow it with compressed air.
 - ❑ For dirt that contains grease/oil, the filter pad should be rinsed with warm water with the addition of a degreaser. Filter pads should not be cleaned with powerful water jets or wrung out.

6. After cleaning and drying the filter pad, place it in the filter mat holder (see Fig. 24).
7. Reattach the filter mat holder to the front side of the fans by inserting the positioning plates (Fig. 23, pos. 6) into the positioning holes (Fig. 22, pos. 3).
8. Fix the filter mat holder by tightening the knurled screw (Fig. 23, pos. 5) to the bolt with tapped hole (Fig. 22, pos. 1) in front of the fans.



Defective components may only be replaced by Kontron original spare parts.

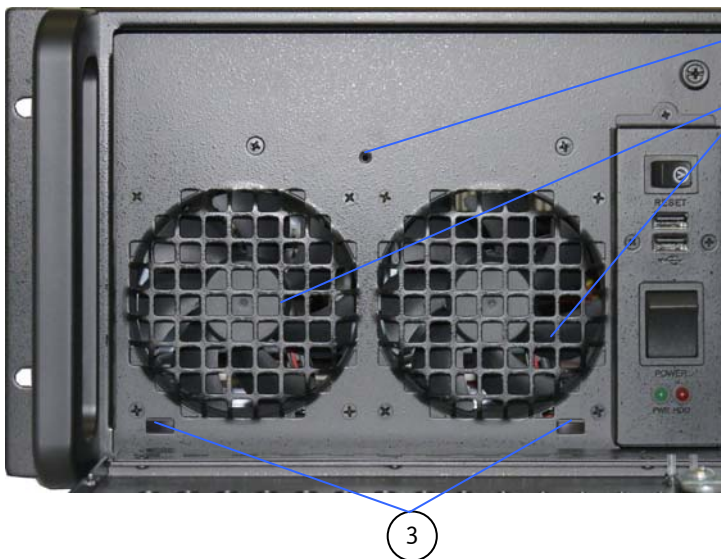

Fig. 22: Detail: without filter mat at the front side

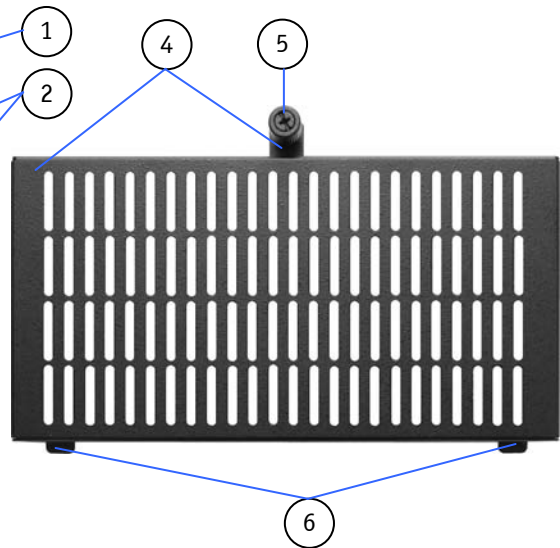

Fig. 23: Filter mat holder without filter mat

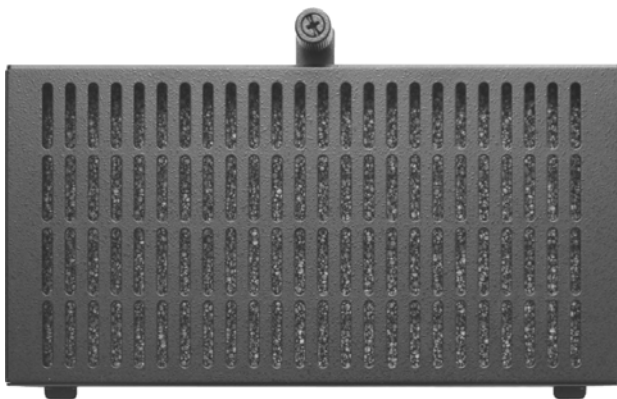

Fig. 24: Filter mat holder with filter mat

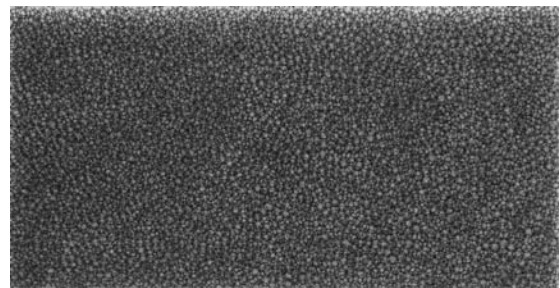

Fig. 25: Filter mat

Legend for Fig. 22 and Fig. 23:

- | | |
|---|---|
| 1 Bolt with tapped hole on the front side for filter mat holder | 4 Filter mat holder |
| 2 Fans behind the air intake openings on the front panel | 5 Knurled screw of the filter mat holder |
| 3 Positioning holes for the filter mat holder | 6 Positioning plates of the filter mat holder |

10.2. Replacing the Lithium Battery

The integrated motherboard of your system is equipped with a lithium battery. To replace the battery, please proceed as follows:

1. Open the unit as described in chapter 8.3.1 "Installing/Removing the Expansion Cards".
2. If you have added expansion cards to your system, first remove the expansion cards plus all the corresponding connecting cables, to gain access to the lithium battery.
3. Remove the lithium battery from the holder by pulling the ejector spring outwards.
4. Place a new lithium battery into the battery holder.
5. Pay attention to the polarity of the battery.
6. The lithium battery must be replaced with an identical battery or a battery type recommended by Kontron Technology India.
7. Reinstall the expansion cards which you removed and reconnect their data cables.
8. Close the device, as described in chapter 8.3.1 "Installing/Removing the Expansion Cards" (step 5).

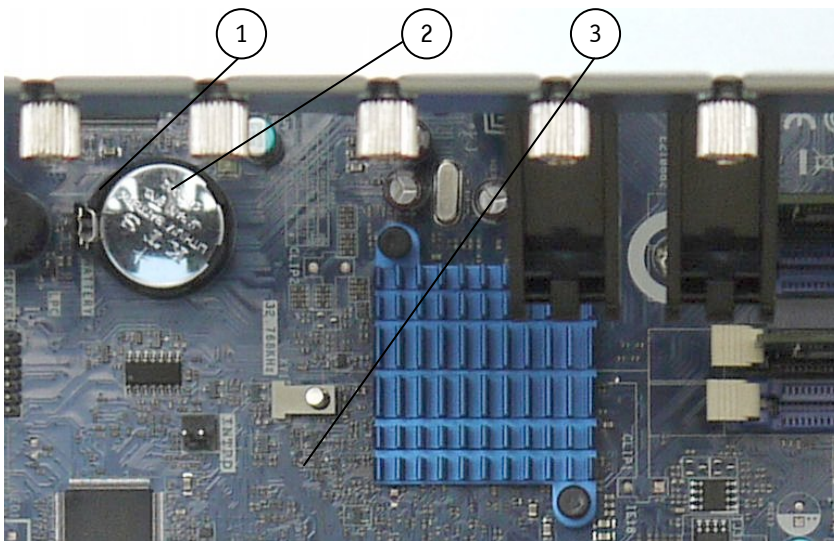

- 1 Battery socket
- 2 Lithium battery
- 3 Motherboard (detail: Intel® DZ77)

Fig. 26: Lithium Battery location



Caution

Danger of explosion when replacing with wrong type of battery. Replace only with the same or equivalent type recommended by the manufacturer. The Lithium battery type must be UL recognized.



Do not dispose of lithium batteries in general trash collection. Dispose of the battery according to the local regulations dealing with the disposal of these special materials, (e.g. to the collecting points for disposal of batteries).

11. Slide Rails (Option)

Kontron recommends the installation the VRack 4U platform into a 19" industrial cabinet by use of slide rails. These can be ordered separately.

12. Technical Data

VRack 4U-xxxxxxx-y	
Installed Board	* See "VRack 4U Systems - Configuration Guides"
Interfaces	I/O interfaces of the CPU card * See manual of the installed motherboard
Drive Bays	Up to six drive bays * Optional equipment, depending on the system configuration ordered (see also "VRack 4U Systems - Configuration Guides")
Free Expansion Slots	Up to 6 slots: PCI, PCIe x1, PCIe x4, PCIe x16 * the type and number of the expansion slots depends on the system configuration ordered (see also "VRack 4U Systems - Configuration Guides" and the corresponding Datasheet on the www.kontron.com)
Lithium Battery	* See manual of the installed motherboard
Rated Voltage Range	See type label



VRack 4U = System type

The "xxxxxxx" group is replaced by up to a max. 8-digit combination of numbers, letter or space, and represents the installed CPU board

The "y" is replaced by a single letter (A through Z) representing the power supply installed into the system.

*The corresponding "VRack 4U Systems - Configuration Guides" and the manual of the installed board can be downloaded from our web site at www.kontron.com by selecting the product name.

12.1. Electrical Specifications

The corresponding electrical specifications of your VRack 4U platform can be found on the type label.

12.2. Mechanical Specifications

Dimensions	VRack 4U xxxxxxxx-y
Height	4U (177 mm) (6.968 ")
Width	Front: 19" (482 mm); Chassis: 430 mm (16.9")
Depth	Chassis: 505 mm (20")
Weight (without Packaging)	Approx. 15 kg (33.069 lbs.)

12.3. Environmental Specifications

Thermal Management	2x System fan 1x CPU fan 1x PSU fan
Operating Temperature	0 ... +50 °C (32 .. 122 °F)
Storage / Transit Temperature	-20 ... +70 °C -4 ... 158 °F
Relative Humidity (Operating/Storage/Transit)	10-95 % @ 40° C, non condensing
Max. Operation Altitude	2,000 m (6,560 ft)
Max. Storage / Transport Altitude	10,000 m (32,810 ft)
Operating Shock	10 G, 11 ms, half sine
Storage / Transit Shock	20 G., 11 ms, half sine
Operating Vibration	10 – 500 Hz, 0.5 G
Storage / Transit Vibration	10 – 500 Hz, 1.0 G
IP Protection Class	Front: IP20

12.4. CE Directives and Standards

CE Directive	
Elektrical Safety	General Product Safety Directive (GPSD) 2001/95/EC Low Voltage Directive (LVD) 2006/95/EC
Electromagnetic Compatibility (EMC)	EMC Directive 2004/108/EC
CE Marking	CE Directive 93/68/EEC
RoHS II Directives	2011/65/EU

Elektrical Safety	Harmonized Standards
EUROPE	Information technology equipment - Safety - Part 1: General requirements EN 60950-1:2006 + A11:2009 + A1:2010 + A12:2011 + AC:2011
U.S.A. / CANADA	to meet UL60950-1:2006/ CSA C22.2- No. 60950-1-7:2007

EMC	Harmonized Standards
EU	Generic emission standard for industrial environments (Emission): EN 61000-6-4:2007 (partly) EN 61000-3-2:2006 + A1:2009 + A2:2009 EN 61000-3-3:2008 Generic standards - Immunity for industrial environments (Immunity): EN 61000-6-2:2005 (partly)
U.S.A.	FCC 47 CFR Part 15, Class A
CANADA	ICES-003, Class A

13. Standard Interfaces – Pin Assignments

Low-active signals are indicated by a minus sign.

13.1.1. Serial Interface (RS232)

Pin	Signal Name	9-pin D-SUB Connector
1	DCD (Data Carrier Detect)	
2	RXD (Receive Data)	
3	TXD (Transmit Data)	
4	DTR (Data Terminal Ready)	
5	GND (Signal Ground)	
6	DSR (Data Set Ready)	
7	RTS (Request to Send)	
8	CTS (Clear to Send)	
9	RI (Ring Indicator)	

13.1.2. VGA Port

Pin	Signal Name	15-pin D-SUB Connector (female)
1	Analog red output	
2	Analog green output	
3	Analog blue output	
4	N.C.	
5-8	GND	
9	+5 V (DDC)	
10	GND	
11	N.C.	
12	SDA (DDC)	
13	TTL HSync	
14	TTL VSync	
15	SCL (DDC)	

13.1.3. Combined PS/2 Keyboard and Mouse Connector

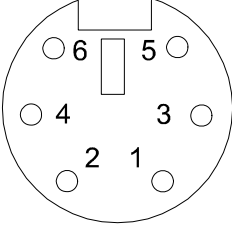
Pin	Signal Name	6-pin Mini-DIN Connector
1	Keyboard Data	
2	Mouse Data	
3	GND	
4	+5 V	
5	Keyboard Clock	
6	Mouse Clock	

13.1.4. PS/2 Keyboard Connector

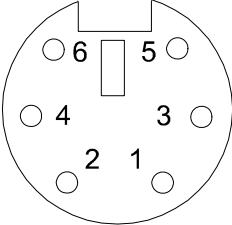
Pin	Signal Name	6-pin Mini-DIN Connector
1	Keyboard Data	
2	N.C.	
3	GND	
4	+5 V	
5	Keyboard Clock	
6	V.C.	

13.1.5. PS/2 Mouse Connector

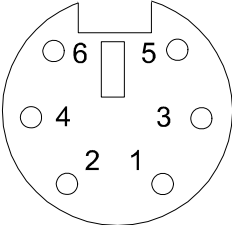
Pin	Signal Name	6-pin Mini-DIN Connector
1	Mouse Data	
2	N.C.	
3	GND	
4	+5 V	
5	Mouse Clock	
6	N.C.	

13.1.6. Parallel Port (LPT)

Pin	Signal Name	25-pin D-SUB Connector (female)
1	-STROBE	
2	DATA0	
3	DATA1	
4	DATA2	
5	DATA3	
6	DATA4	
7	DATA5	
8	DATA6	
9	DATA7	
10	-ACKN	
11	BUSY	
12	PE	
13	SELECT	
14	-AUTOFD	
15	-ERROR	
16	-INIT	
17	-SLCTIN	
18-25	GND	

13.1.7. USB Port

Pin	Signal Name	4-pin USB Connector Type A Version 2.0
1	VCC	
2	Data-	
3	Data+	
4	GND	

14. Technical Support

For technical support, please contact our Technical Support department:

Tel: +91 80 40831006

e-mail: support@kontron.in

Web: <http://www.kontron.in/support>

Make sure you have the following information on hand when you call:

- the unit part id number (PN),
- the serial number (SN) of the unit; the serial number can be found on the type label, placed on the right side of the system.

Be ready to explain the nature of your problem to the service technician.

If you have questions about Kontron Technology India or our products and services, you can reach us by the above-mentioned telephone number and on e-mail address or at: www.kontron.in

14.1. Returning Defective Merchandise

Please follow these steps before you return any merchandise to Kontron Technology India:

1. Download the corresponding form for returning a device with an RMA No. [RMA (Return of Material Authorization)] from our website www.kontron.in / Support /.RMA Information; contact our Customer Service department to obtain an RMA No.
e-Mail: support@kontron.in
2. Ensure that you have received an RMA number from Kontron Customer Services before returning any device. Write this number clearly on the outside of the package.
3. Describe the fault that has occurred.
4. Please provide the name and telephone number of a person we can contact to obtain more information, where necessary. Where possible, please enclose all the necessary customs documents and invoices.
5. When returning a device:
 - Pack it securely in its original box.
 - Enclose a copy of the RMA form with the consignment.

Corporate Office

Kontron Technology India Pvt Ltd.
425, 2nd Main Road, Kasthurinagar,
East of N.G.E.F., Nr Outer Ring Road,
Bangalore – 560043,
INDIA

